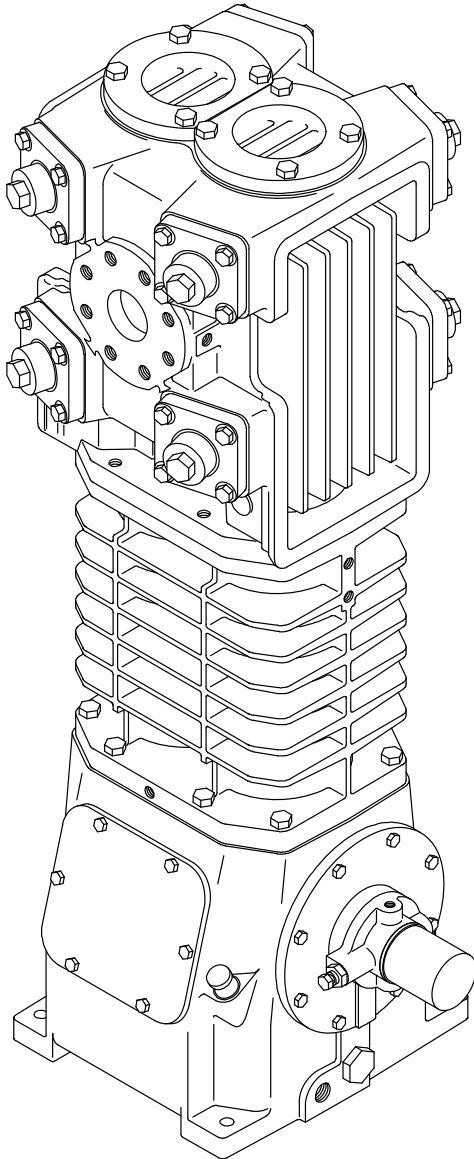

NGS Sour Gas Compressors

**NGS082****NGS162****NGS362****Single-Stage NGS602****NGS642****NGS942****NGS172****Two-Stage NGS372****NGS612**

- 10 to 600 MSCFD
- 3 to 50 HP
- Ductile iron pressure parts
- Single compartment distance pieces
- Pressure lubricated crankcases
- Non-lubricated air-cooled cylinders

APPLICATIONS

Well Head Annulus Reduction

Many compressor applications are found at the wellhead where reducing the natural gas pressures around the annulus of the well increases the oil production. Blackmer's unique ability to handle a wide range of suction pressure conditions make them ideal for many wellhead applications.

Tank Battery Vapor Recovery

Environmental regulations are now being enforced that limit the amount of methane gas emissions that can be vented to the atmosphere from crude storage tanks. Blackmer's wide range of small frame sizes are an ideal fit for the small to mid size tank batteries that need VR control.

In either case, Blackmer NG compressors are standard with a full distance piece design allowing users to maintain maximum control of any fugitive emissions of methane gas, and minimize the potential of condensate into the compressor crankcase.

SPECIFICATIONS

Single-Stage	NGS082	NGS162	NGS362	NGS602	NGS642	NGS942
No. of Cylinders	1	2	2	2	2	2 Double Acting
Bore x Stroke in. (mm)	3.0 x 2.5 (76.2 x 63.5)	3.0 x 2.5 (76.2 x 63.5)	4.0 x 3.0 (102 x 76)	4.625 x 4.0 (117 x 102)	3.25 x 4.0 (82.5 x 102)	4.625 x 4.0 (117 x 102)
MAWP, psia (Bar)	350 (24.1)	350 (24.1)	350 (24.1)	350 (24.1)	515 (35.5)	350 (24.1)
Speed, rpm	350 – 825	350 - 825	350 - 825	350 - 825	350 - 825	350 - 825
Piston Displacement, CFM (m ³ /hr)						
@ Min rpm	3.58 (6.1)	7.16 (12.2)	15.3 (26.0)	27.2 (46.3)	13.4 (22.8)	52.46 (89.1)
@ Max rpm	8.45 (14.35)	16.9 (28.7)	36.0 (61.2)	64.2 (109.0)	31.7 (53.8)	125.2 (212)
Piston rod dia. - in. (mm)	.75 (19.1)	0.75 (19.1)	0.75 (19.1)	1.25 (31.8)	1.25 (31.8)	1.25 (31.8)
Max. Discharge Temp.	350°F (176°C)					
Max. BHP (kw)	7.5 (5.5)	10 (7.5)	15 (11)	40 (30)	40 (30)	50 (37)
Weight, lb. (kg)	~215 (97)	~225 (102)	~365 (166)	~705 (320)	~725 (329)	~905 (410)
Inlet / Outlet Connections	0.75" NPT	0.75" NPT	1.5" 300# ANSI	2" 300# ANSI	2" 300# ANSI	2" 300# ANSI
Maximum H ₂ S	8%					

Two-Stage	NGS172	NGS372	NGS612
No. of Cylinders	2	2	2
Bore – Stage 1 in. (mm)	3.0 (76.2)	4.63 (117)	6.0 (152)
Bore – Stage 2 in. (mm)	1.75 (44.5)	2.69 (68)	3.25 (83)
Stroke in. (mm)	2.5 (63.5)	3.0 (76)	4.0 (102)
MAWP, psia (Bar)	615 (42.4)	615 (42.4)	415 (28.6)
Speed, rpm	350 - 825	350 - 825	350 - 825
Piston Displacement, CFM (m ³ /hr)			
@ Min rpm	3.57 (6.07)	10.2 (17.3)	22.9 (38.9)
@ Max rpm	8.42 (14.3)	24.1 (40.8)	53.7 (91.2)
Piston rod dia. - in. (mm)	0.75 (19.1)	0.75 (19.1)	1.25 (31.8)
Max. Discharge Temp.	350°F (176°C)		
Max. BHP (kw)	10 (7.5)	15 (11)	40 (30)
Weight, lb. (kg)	~245 (111)	~405 (184)	~775 (352)
Inlet / Outlet Connections	0.75" NPT	1.25" x 1" NPT	2" x 1.5" NPT or Weld
Maximum H ₂ S	8%		



STANDARD FEATURES

Ductile Iron Head & Cylinder provide toughness & strength unmatched by cast iron.
Stainless Steel fasteners in all gas containment areas.
Select parts of reduced hardness material for sour gas application compatibility.
O-Ring head gaskets provide positive sealing under all operating conditions.
Double-Seal with full size distance piece.
One piece steel pistons are attached to the piston rod via one positive locking nut.
Self-adjusting PTFE piston rod seals provide maximum sealing & minimum friction.
Steel wrist pins ride on steel needle bearings for extra life under severe conditions.
Ductile Iron crossheads
Pressure lubricated crankcase via a self-reversing oil pump directly driven by the crankshaft.
Oil is fed to the crosshead and all bearing surfaces.
External Oil Filter.
Epoxy paint.

OPTIONS

Baseplates – Formed or Structural Steel
Belt guards: Steel, Aluminum or Stainless
Repair tool kits

PERFORMANCE

Please refer to CB174 available at www.blackmer.com

TYPICAL MOUNTING STYLES

-CO Compressor with flywheel.
-B Compressor mounted on a baseplate with V-belt drive system with guard and motor slide base ready to accept but less motor.

Complete system packaging is typically provided by the Distributor, OEM or System Integrator.



DIMENSIONS

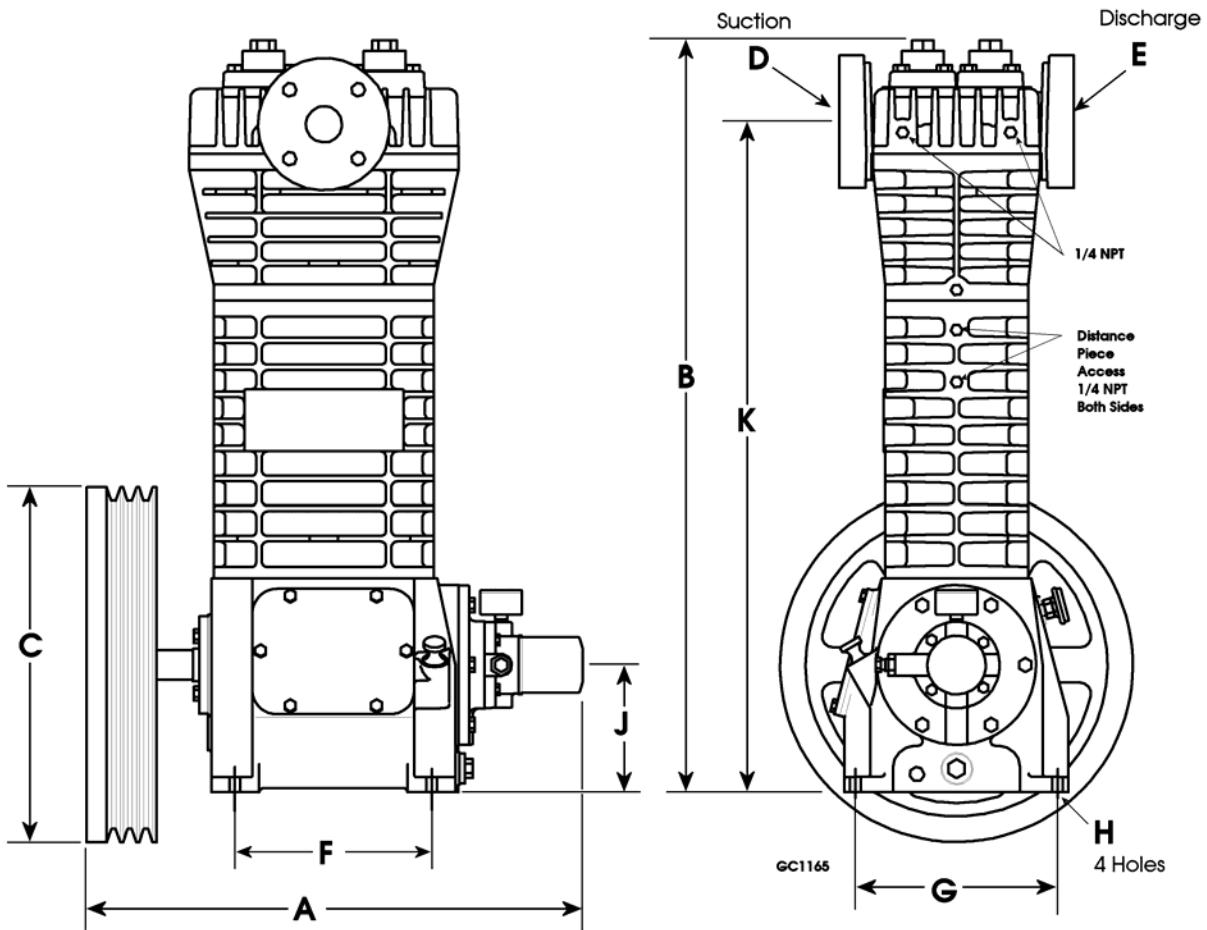

In. (mm)

Model	A	B	C	D	E	F	G	H	J	K
NGS082	21.9 (556)	30.2 (767)	16.35 (415)	3/4" NPT	3/4" NPT	7.5 (191)	7.38 (187)	0.44 (11)	5.37 (136)	27.4 (695)
NGS162	21.9 (556)	29.7 (755)	16.35 (415)	3/4" NPT	3/4" NPT	7.5 (191)	7.38 (187)	0.44 (11)	5.37 (136)	27.34 (694)
NGS362	23.4 (594)	34.7 (880)	16.35 (415)	1.5" ANSI 300#	1.5" ANSI 300#	9.12 (232)	9.37 (238)	0.5 (12.7)	5.88 (149)	30.79 (782)
NGS602	25.6 (650)	41.0 (1,042)	20.35 (517)	2" ANSI 300#	2" ANSI 300#	10.5 (267)	12.0 (305)	0.56 (14.2)	8.25 (210)	37.0 (940)
NGS942	25.56 (649)	45.23 (1,149)	21.2 (538)	2" ANSI 300#	2" ANSI 300#	10.5 (267)	12.0 (305)	0.56 (14.2)	8.25 (210)	37.63 (956)
NGS172	21.9 (556)	29.7 (755)	16.35 (415)	3/4" NPT	3/4" NPT	7.5 (191)	7.38 (187)	0.44 (11)	5.37 (136)	27.37 (695)
NGS372	23.4 (594)	34.7 (880)	16.35 (415)	1 1/4" NPT	1" NPT	9.12 (232)	9.37 (238)	0.5 (12.7)	5.88 (149)	30.79 (782)
NGS612	26.4 (671)	41.3 (1,204)	20.35 (517)	2**	1.5**	10.5 (267)	12.0 (305)	0.56 (14.2)	8.25 (210)	37.22 (1,101)

** 2"NPT, 1.5"NPT, 2"Weld, & 1.5"Weld Available

