

EBSRAY PUMPS

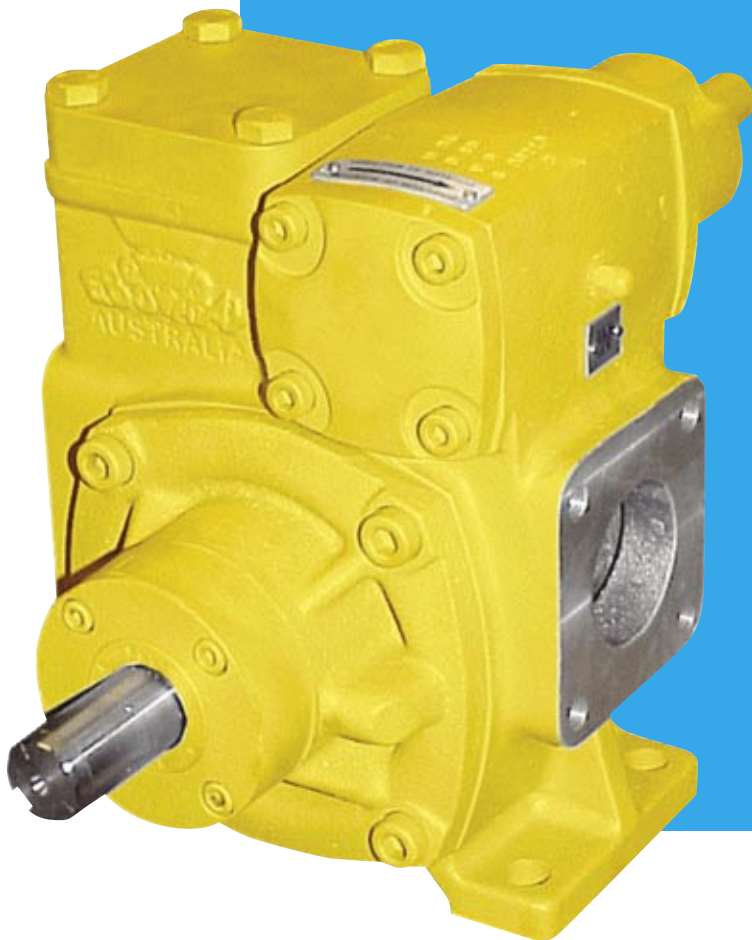

V Series *Model V15*



V Series – Model V15



Designed and precision built for efficient transfer of a variety of liquids over a wide range of viscosities with lubricating or non-lubricating characteristics.

Specifications

Max Flow	to 345 L/min
Max Differential Pressure	to 1100 kPa
Viscosity range	<1 to 10,000 cSt
Temperatures	to 100°C as standard

Features

- ▼ Quiet operation
- ▼ High overall efficiency
- ▼ Low maintenance – long life
- ▼ Internal wearing parts replaceable without removing pump from piping
- ▼ Variable mounting options. 90° or 180° port configuration
- ▼ Double ended shaft option
- ▼ Direct coupling to synchronous speed electric motors, speed variators, PTOs or engine driven
- ▼ Facility for close coupled hydraulic motor connection
- ▼ Belt drives
- ▼ Lightweight – Robust – Compact
- ▼ Positively actuated vanes
- ▼ Integral adjustable relief valve
- ▼ Mechanical Seals as standard
- ▼ CE marked, ATEX compliant for specific applications

Typical Services

- Transport tanker services
- Petroleum and fuel industries
- Chemical and pharmaceutical industries
- Power stations
- Paint industry
- Public utilities
- Edible oil industry
- Aviation industry

Common Liquid Applications

- Fuel oils
- Lube oils
- Distillate
- Petrol
- Kerosene
- Transformer oils
- Solvents
- Chemicals
- Edible oils
- Aviation fuels

Assured Quality and Performance

EBSRAY's ISO 9001:2000 Quality Management System assures compliance with high safety and quality standards.

All Ebsray V Series Model V15 pumps are manufactured under strict guidelines and procedures and are run tested prior to dispatch in order to ensure performance in accordance with pump specifications.

The high standards of engineering design, manufacturing and testing combine to make the V15 pumps capable of a long and trouble-free service life.

Special Constructions

Contact EBSRAY or your local representative for advice on alternative arrangements to meet applications not outlined in this brochure.

Ebsray Pumps are designed and manufactured in Australia

Performance Data

Efficiency Graph

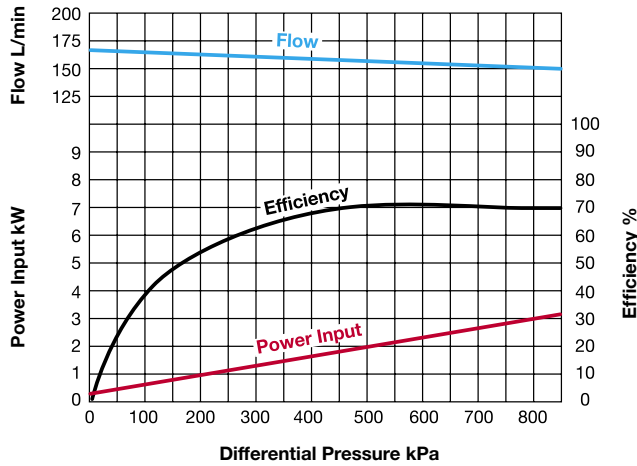

High Pump Efficiency

Being of the 'Sliding Vane Principle' all EBSRAY V SERIES pumps will operate efficiently over a wide range of pressures, viscosities and speeds.

A typical illustration is shown in the diagram opposite, and under ideal conditions it is possible to attain higher efficiency than shown here. The diagram shows a typical performance of V Series Model V15.

Speed = 720 rpm
Kinematic Viscosity = 10 cSt

1 cSt

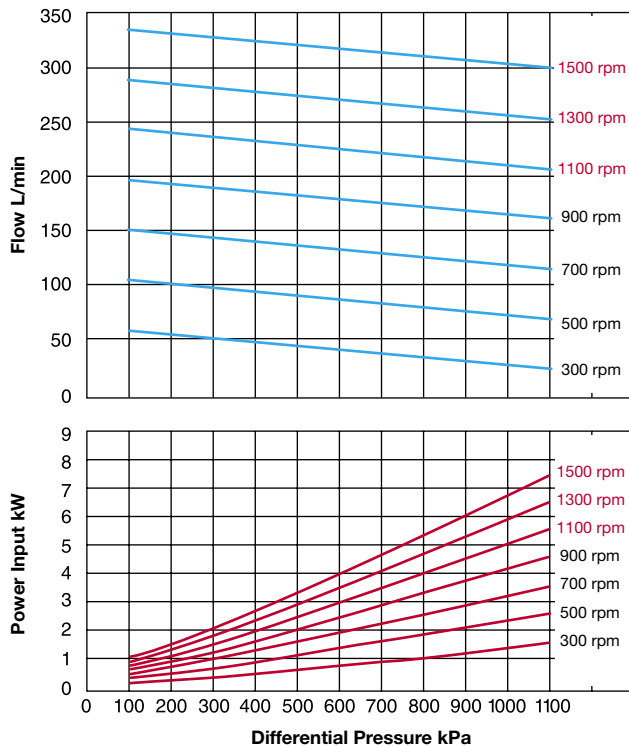

10 cSt

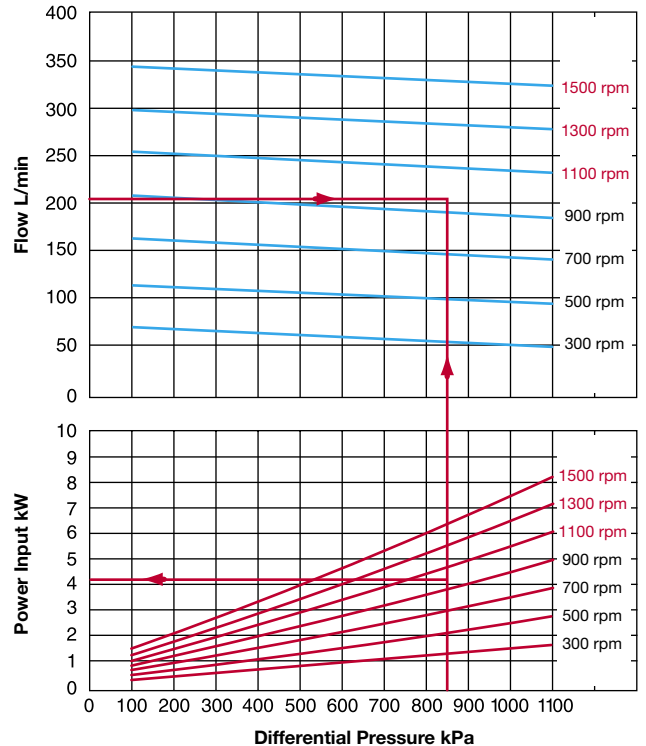

Using these Graphs

Example Flow 205 L/min
Differential Pressure 850 kPa
Viscosity 10 cSt

Select the 10 cSt graph. Trace a horizontal line from 205 L/min of Flow on the Y-axis and another line vertical upward from 850 kPa of Differential Pressure on the X-axis. At the point where the two lines intersect each other in the Flow curve graph, estimate the operating speed between the Flow curves, i.e. 960 rpm. Transfer vertically downward to the point where

an imaginary 960 rpm Power Input curve would intersect. Draw a horizontal line from this point to the left and read off the required Power Input on the Y-axis, i.e. 4.2 kW. Motor selection is 5.5 kW at indicated speed. Pump may be directly coupled to a correctly rated 960 rpm synchronous motor. Please refer to notes on POWER INPUT on next page.

100 cSt

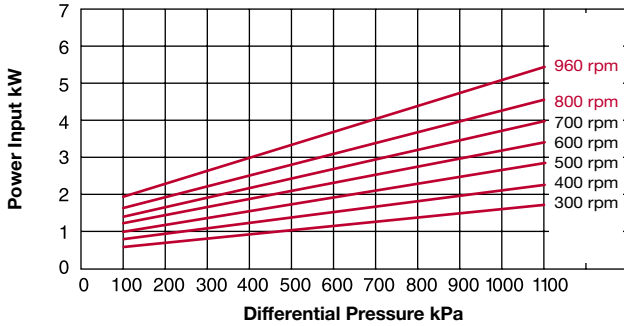
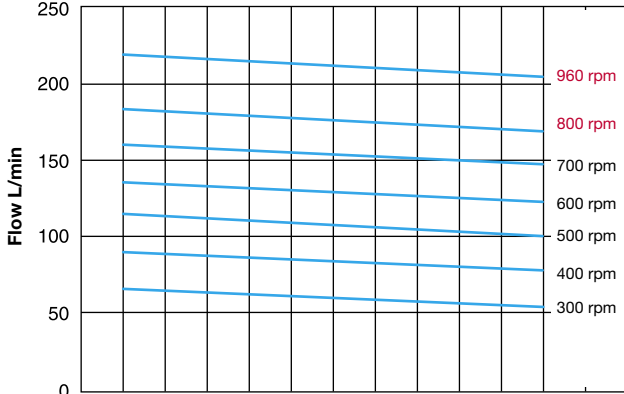

500 cSt

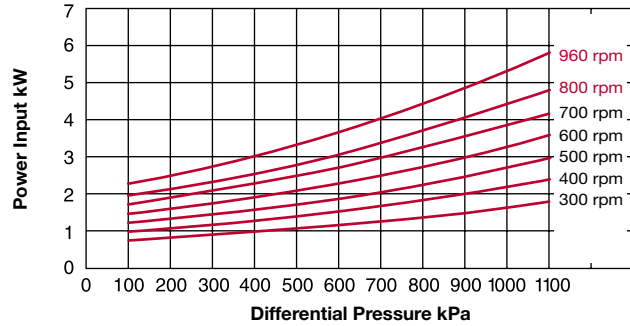
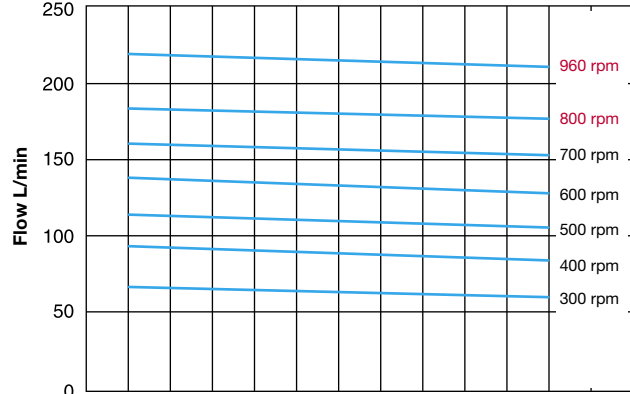

1000 cSt

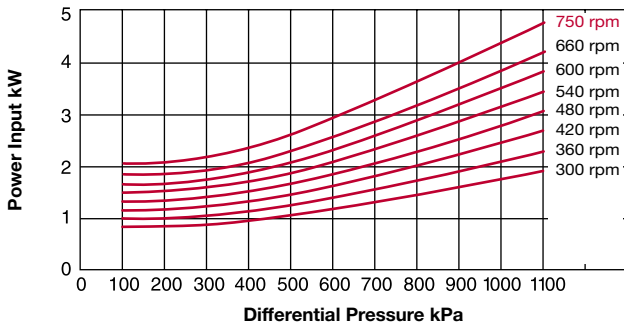
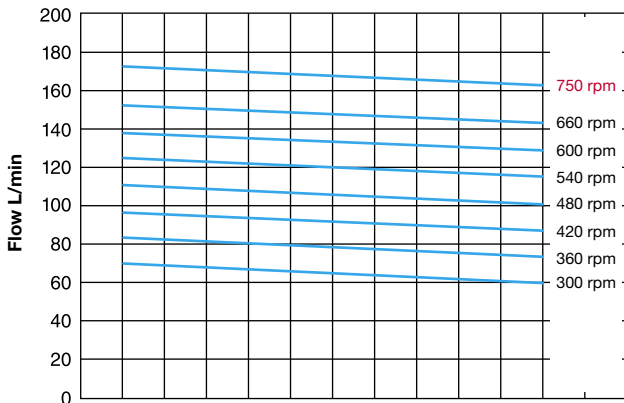

3000 cSt

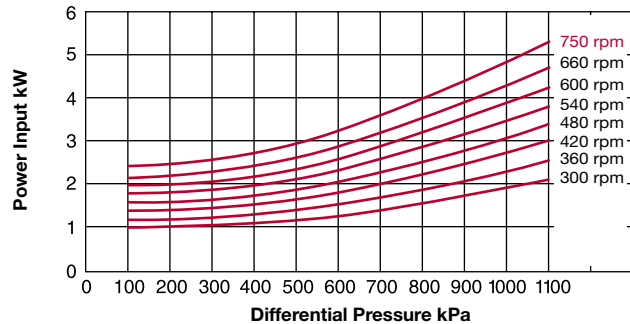
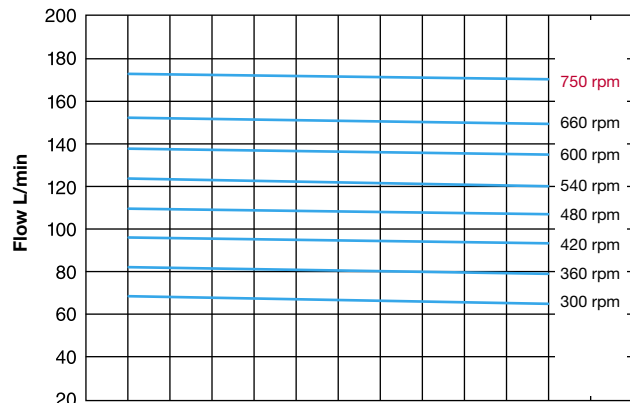

Notes

1. POWER INPUT (kW) specified is measured under precisely controlled testing conditions of speed, kinematic viscosity and differential pressure. Any variation in these parameters will alter POWER INPUT. Therefore adequate allowances must be made over and above POWER INPUTS indicated for losses due to drives, couplings, gearboxes, etc, as well as margins for variables such as viscosity change and bypass valve pressure rise when determining power required.
2. Graphs show speed ranges (rpm) to a safe maximum at which the pump may be run on a given viscosity.
3. Pump performance may be affected by NPSHa. This should be verified for each application.
4. Speeds shown in Red colour print are maximums. Ensure adequate NPSHa or contact EBSRAY.
5. For parameters outside those printed above contact EBSRAY or representative for details.

Features and Options

PORTS

- 3 - Ports, 90° or 180° configuration – for easy installation
- Flanges for screwed or welded pipe connections

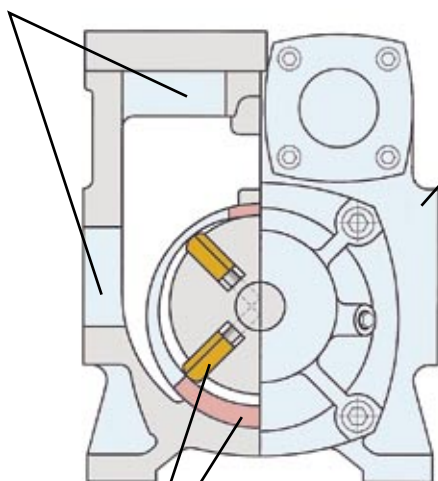

CASING / BODY

- Lightweight Body in Aluminium
- O-Ring Seals on all pressure retaining joints – simple to service

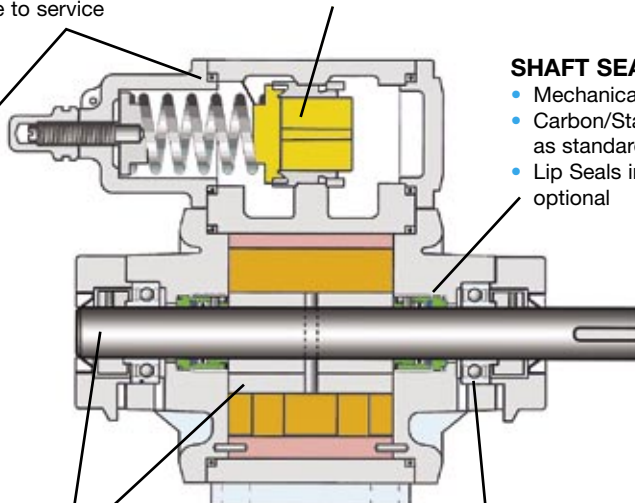

RELIEF VALVE

- Low pressure rise
- Fully adjustable within spring range
- Full flow capability
- Replaceable Valve Seat

SHAFT SEALS

- Mechanical Seals
- Carbon/Stainless/Viton as standard
- Lip Seals in Viton optional

VANES / LINER

- Positively actuated synthetic Vanes
- Self compensation for wear
- Replaceable Liner in Cast Iron (Stainless optional)

ROTOR / SHAFT

- Rotor in high tensile Cast Iron (Stainless optional)
- Axially located
- Shaft in high tensile Alloy Steel (Double ended optional)
- Precision ground surfaces

BEARINGS

- Heavy duty sealed grease packed Ball Bearings
- Locked to shaft for axial location
- Bearing Housing in Cast Iron (Stainless optional)
- Dust Seals for extra protection against moisture and dirt

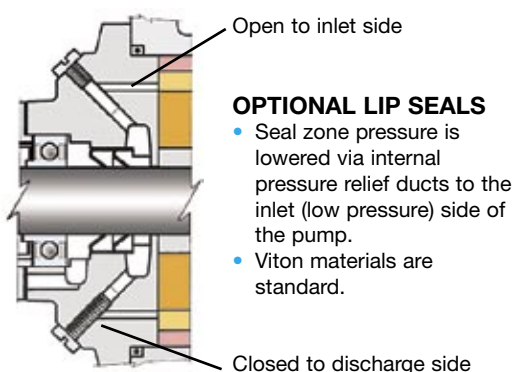

OPTIONAL LIP SEALS

- Seal zone pressure is lowered via internal pressure relief ducts to the inlet (low pressure) side of the pump.
- Viton materials are standard.

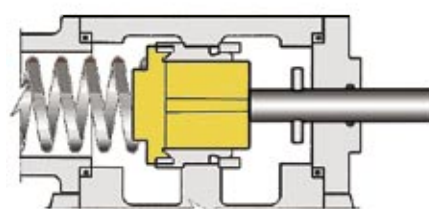

OPTIONAL FPC VALVE

Ebsray's Flow and Pressure Control (FPC) valve allows manual unloading of the system pressure and also reduction of output flow without the need for reduction in pump speed. This feature enables the V15 to be used for bulk liquid transfer (high flow) as well as low flow application such as drum filling, aircraft refuelling, hose reel deliveries, etc., without the need for an expensive speed variator.

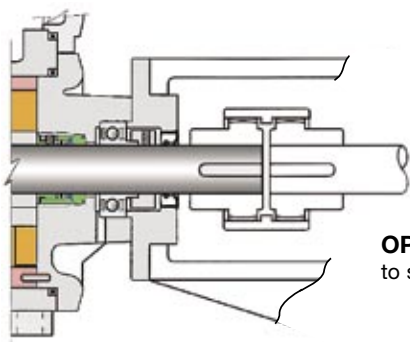

OPTIONAL BEARING CAP to suit Hydraulic Drive Adaptor

Dimensions

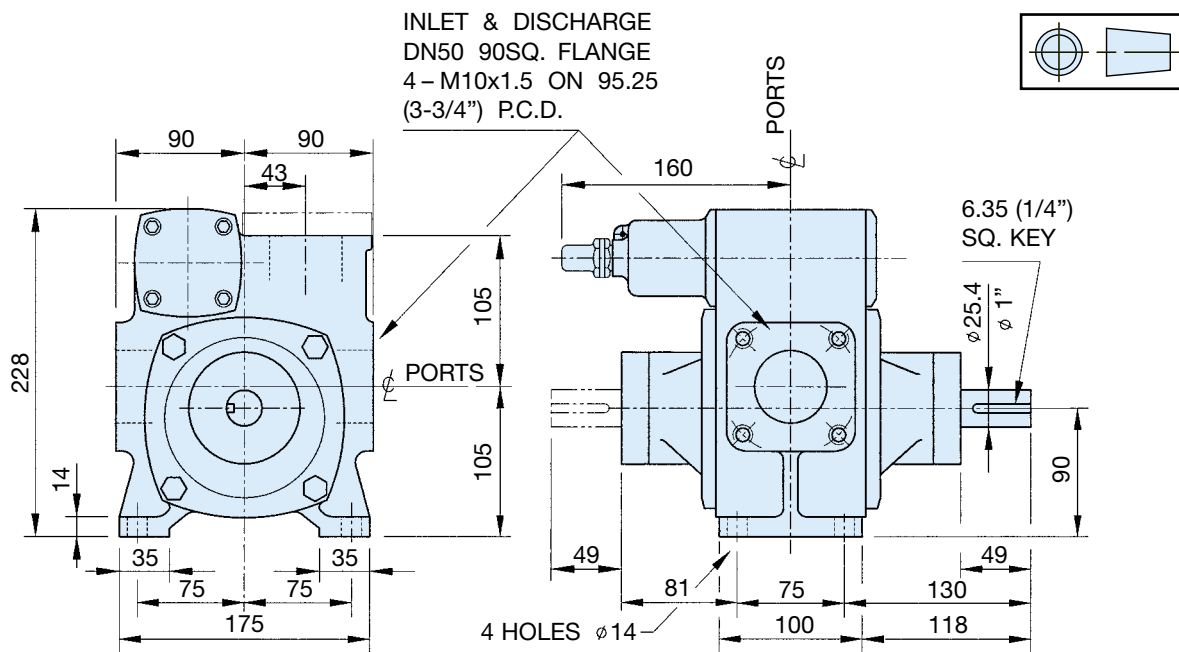

Standard Materials of Construction

Body	Aluminium
Liner	Cast Iron (Stainless optional)
Rotor	Cast Iron (Stainless optional)
Shaft	High Tensile Steel (Stainless optional)
Vanes	Synthetic
Bearing Housing	Cast Iron (Stainless optional)

Pump Weight: 18 kg
Configuration as drawn: V1 - V2

Multi Porting / Drive Configurations

Unique 3-ports pump design allows great versatility of mounting options. Ports permit pump to be set up as either 180° or 90° configuration. V2, V4 and V6 are the preferred types.

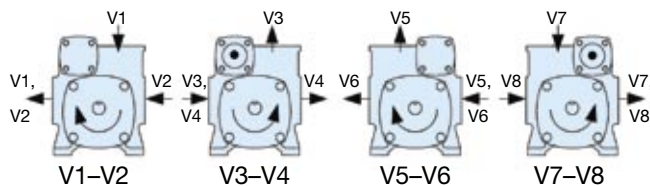

Note: All specifications and illustrations are typical only and subject to revision without notice. Certified data available on request.

Distributed By:

EBS-RAY PUMPS PTY. LIMITED

ABN 52 000 061 003

Head Office and Works
628 Pittwater Road
Brookvale NSW 2100
Australia.

Branch Office Victoria
Phone: (03) 9706 7263
Fax: (03) 9706 7312

Phone: (+61 2) 9905 0234
Fax: (+61 2) 9938 3825
www.ebsraypumps.com.au

Branch Office Queensland
Phone: (07) 3260 7411
Fax: (07) 3260 7422

