

BioProTT™ FlowMCP

User Manual

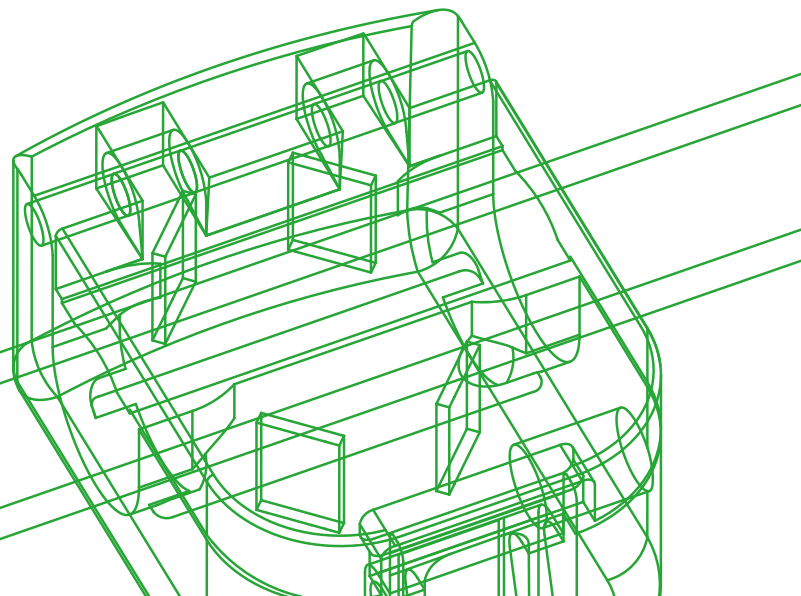

Copyright

All rights reserved, especially with respect to reproduction, distribution and translation. This user manual or any part thereof must not be reproduced, saved, processed, duplicated or distributed without the written consent of em-tec GmbH.

© Copyright em-tec GmbH Finning, 2021

Subject to Technical Changes

Owing to our policy of continuous product improvement, the illustrations and technical data contained in this document may differ slightly from the current version of the device.

Legal Manufacturer

em-tec GmbH
Lerchenberg 20
86923 Finning
GERMANY

Telefon: +49 8806 9236 0
Fax: +49 8806 9236 50
E-Mail: em-tec-info@psgdover.com
Internet: www.em-tec.de



Table of Contents

1	Intended Purpose and Restrictions.....	8
1.1	Intended Purpose	8
1.2	Usage Restrictions and Limitations.....	8
1.3	Liabilities and Responsibilities.....	8
1.4	Safety Instructions	9
1.5	Maintenance and Service.....	9
2	General Safety Information, Symbols, Units and Abbreviations.....	10
2.1	Symbols used in this User Manual	10
2.2	Symbols on Flow Meter, Sensors and on Packaging.....	10
3	Description of the Measurement Principle.....	11
4	Packaging Contents	12
5	Installation of the BioProTT™ FlowMeasurement System	13
5.1	Device Description: BioProTT™ FlowMCP (1-4 channels)	13
5.2	Device Description: BioProTT™ FlowMCP-a (1 or 2 channels)	15
5.3	Installation of the BioProTT™ FlowMCP.....	17
5.4	Powering of BioProTT™ FlowMCP	18
5.5	Connecting the BioProTT™ Clamp-On to the BioProTT™ FlowMCP.....	19
5.6	Mounting and Installation of the BioProTT™ Clamp-On and the Extension Cables.....	19
5.7	Line Routing, Shield and Measures to Combat Interference Voltage.....	20
5.8	Attaching the BioProTT™ Clamp-On to the Tube	22
5.9	Use of the BioProTT™ Clamp-On.....	23
5.10	Changing the BioProTT™ Clamp-On	24
5.11	Disassembly and Storage of the BioProTT™ Clamp-On	24
5.12	Cleaning and Disinfection of the BioProTT™ Clamp-On.....	24
5.13	Initialization and Start-Up of the BioProTT™ FlowMCP	25
6	Web Interface of the BioProTT™ FlowMCP	26
6.1	Main Web Page for the BioProTT™ FlowMCP (1-4 channels).....	26
6.2	Main Web Page for the BioProTT™ FlowMCP-a.....	29
6.3	Sensor Information Page for the BioProTT™ FlowMCP	32
6.4	Set-Up Page of the BioProTT™ FlowMCP	34
6.5	Logging Page of the BioProTT™ FlowMCP	43
7	Modbus Interface	44
7.1	Read Input Register (Function Code: 0x04)	44
7.2	Read Discrete Inputs (Function Code: 0x02)	47
7.3	Write Coil (Function Code: 0x05)	47
7.4	Read Coil (Function Code: 0x01)	48
7.5	Write Register (Function Code: 0x06).....	48

8 Analog Interface49

8.1 Measurement Using the Analog Interface of the BioProTT™ FlowMCP-a..49

8.2 Zero Flow Adjustment via the Analog Interface 52

9 Cleaning the BioProTT™ FlowMCP 53

10 Troubleshooting, Support and Service.....54

10.1 Troubleshooting..... 54

10.2 Status Information Troubleshooting..... 70

11 Electrical Safety and Electromagnetic Compatibility 72

12 Environmental Protection and Disposal..... 72

13 Manufacturer's Declarations 72

14 Contact Information for Technical Support 72

15 Technical Specifications of the BioProTT™ FlowMCP (1-4 channels) 73

16 Technical Specifications of the BioProTT™ FlowMCP-a 74

EN

Before you set up or use the BioProTT™ FlowMCP (1-4 channels) or the BioProTT™ FlowMCP-a (1 or 2 channels), please note:

- This user manual describes the BioProTT™ FlowMCP (1-4 channels) as well as the BioProTT™ FlowMCP-a, the BioProTT™ FlowMCP version with analog interface (available as one or two channel version).
- Throughout this user manual, the term BioProTT™ FlowMCP is used to refer to all versions of the BioProTT™ FlowMCP, i.e. with or without analog interface, unless clearly indicated otherwise.
- When referring to the BioProTT™ FlowMCP (both with and without analog interface) this usually also includes the BioProTT™ Clamp-On as both devices need to be used together in order to form the complete BioProTT™ FlowMeasurement System consisting of the flow meter and corresponding sensor.
- This user manual refers to the features of software version V02.04.11.00 and subsequent ones. The software version of your device is also displayed on the web interface.

Abbreviation	Meaning
BioProTT™ FlowMCP	BioProTT™ FlowMCP (1-4 channels); including BioProTT™ FlowMCP 1-a and 2-a. MCP = Multi-Channel Platform
BioProTT™ FlowMCP -a	BioProTT™ FlowMCP with analog interface
BioProTT™ FlowMeasurement System	The BioProTT™ FlowMeasurement System consists of the BioProTT™ FlowMCP (1-4 channels)/ BioProTT™ FlowMCP-a (1 or 2 channels), a BioProTT™ Clamp-On, and the corresponding cables.
flow meter	Referring to the BioProTT™ FlowMCP
sensor	BioProTT™ Clamp-On
Qmin	Minimum flow the connected sensor was calibrated and adjusted for.
Qmax	Maximum flow the connected sensor was calibrated and adjusted for.
RSS	R eceived S ignal S trength which corresponds to the acoustic coupling
EMC	E lectro M agnetic C ompatib l ity
N/A	Not applicable
PLC	P rogrammable L ogic C ontroller
ID	I nn e r D iameter
OD	O ut e r D iameter
S7	Siemens S7 PLC (Programmable Logic Controller (in German SPS))

Table 1: Abbreviations



- Read this user manual carefully before installing and starting up the device!
- The user (= the person who integrates the BioProTT™ FlowMCP into a control cabinet) is responsible for any risks resulting from an incorrect or incomplete integration of the BioProTT™ FlowMCP.
- The customer must ensure that the persons involved in the integration of the BioProTT™ FlowMCP are adequately qualified in regard to the integration of industrial and process measurement transmitters. In addition, the information in this user manual must be followed.
- Before the first use after the BioProTT™ FlowMCP was transported or taken from storage, ensure that the system has enough time to adapt to the ambient temperature in order to ensure an accurate measurement.
- Due to possible failures of the BioProTT™ FlowMCP or the system it is part of, em-tec GmbH strongly advises against the use of the flow values provided by the BioProTT™ FlowMCP to directly control the closed loop system unless the risk was fully analyzed and additional risk control measures have been established.
- If the used BioProTT™ Clamp-On is switched to another flow channel, if another BioProTT™ Clamp-On is used, or if the BioProTT™ Clamp-On is unplugged and reconnected, it must be reconfigured prior to the measurement (e.g. zero flow adjustment).
- The BioProTT™ FlowMCP, the BioProTT™ Clamp-On(s), and sensor lines are part of a sensitive sensor system. Electromagnetic fields can lead to interferences affecting the measurements or the accurate function of the system.
- The BioProTT™ FlowMCP consists of components sensitive to electrostatic discharge. Handle only in EMV-protected areas according to **IEC 61326-1**.

Although the BioProTT™ FlowMeasurement System represents a state-of-the-art technology, the user may be put at risk if the device is operated incorrectly. You should therefore read the user manual carefully before use. Inspect your equipment for completeness and damage after unpacking.

This user manual contains important information on the safe handling of the BioProTT™ FlowMeasurement System and its accessories and should be kept in an easily accessible location. Familiarize yourself with, and observe all warning and safety information.

It is the responsibility of the operator (=the person carrying out the flow measurement and/or the person operating the system the BioProTT™ FlowMCP is part of) of the device to ensure it is used, inspected and maintained in accordance with the user manual. Subsequent revisions or instructions from the manufacturer must also be taken into account in this regard.

The manufacturer reserves the right to modify technical data without prior notice. Your local distributor will supply you with current information and updates to this user manual.

1 Intended Purpose and Restrictions

1.1 Intended Purpose

The BioProTT™ FlowMeasurement System in general and thus also the BioProTT™ FlowMCP are designed for the measurement of volumetric flows of liquids in tubing circuits. The measurement is based on the ultrasonic transit time method. It is usually used in laboratory, bioprocessing and industrial processes. The device is intended to be mounted and used in a control cabinets only. The device must be used with compatible em-tec BioProTT™ Clamp-Ons.

1.2 Usage Restrictions and Limitations

The BioProTT™ FlowMCP was developed and is sold for the above-mentioned intended purpose and use only. The BioProTT™ FlowMCP and the BioProTT™ Clamp-Ons are not intended to be used for the following purposes/under the following circumstances:

- as medical device
- for measuring gaseous media or explosive and/or flammable liquids
- for measurements in explosive areas
- for home or consumer use
- for outdoor use
- for legal metrology
- when the housing is damaged

Due to the single-channel structure of each individual channel, the BioProTT™ FlowMCP is not a fail-safe system. If applied in safety-critical systems, the user has to consider a partial or complete system failure and is responsible for the introduction of additional risk measures in their system.

For more information concerning compatible BioProTT™ Clamp-Ons, please contact em-tec GmbH.

1.3 Liabilities and Responsibilities

The user is responsible to use, check and maintain the BioProTT™ FlowMCP and the BioProTT™ Clamp-On in accordance with the user manual. em-tec GmbH is neither liable nor responsible for any consequences arising from the use of the BioProTT™ FlowMCP and/or the BioProTT™ Clamp-On that does not comply with the operating and safety instructions or the specifications in this user manual.

1.4 Safety Instructions

If the BioProTT™ FlowMCP is integrated into an industrial system, the user and operator have to observe the following:

- The measured values supplied by the BioProTT™ FlowMCP report the volumetric flow rate via Modbus TCP and/or analog interface.
- If the unit is used to control the liquid volume flow, the user must analyze the risk of the application and, if necessary, take actions independent of the BioProTT™ FlowMCP to minimize the risk.
- In case of an error, the device will provide error/warning information. More information regarding the suggested action to solve the respective error/warning can be found in chapter 10 "Troubleshooting".

EN

1.5 Maintenance and Service

In general, em-tec GmbH recommends the device to be checked in regard to measuring accuracy and safety relevant aspects every two years.

The service for the BioProTT™ FlowMCP and the BioProTT™ Clamp-On may be carried out by em-tec GmbH only. If these instructions are not followed, em-tec GmbH shall accept no liability for the device and the warranty will be void.

If you experience any trouble with the measurement despite following the instructions in this document, or if your BioProTT™ FlowMCP is damaged in any way, please contact our service department. Make a note of the serial number of the BioProTT™ FlowMCP and the sensor before you contact our staff.

If you need to return the BioProTT™ FlowMCP and/or the BioProTT™ Clamp-On for servicing, please follow these steps:

- Contact our service department at:
em-tec GmbH
Service Department
Am Graben 6-8
86923 Finning
Germany
em-tec-service@psgdover.com
- Our service department will send you a RMA form.
- Fill out the form and include it in the shipment.

2 General Safety Information, Symbols, Units and Abbreviations

2.1 Symbols used in this User Manual











Symbol	Meaning
	Warning! This safety symbol precedes critical information that must be strictly observed in order to prevent injuries and fatal hazards. This warning symbol is the most important safety symbol.
	Caution! Important information regarding correct handling. Must be strictly observed! If this information is not observed, faults or damage to the product or its surroundings may occur.

Table 2: Symbols in this User Manual

2.2 Symbols on Flow Meter, Sensors and on Packaging

Symbol	Meaning
	Read this user manual carefully before use. Keep it in an easily accessible location for future reference. Replacement copies of this user manual are available from the manufacturer.
	Manufacturer em-tec GmbH · Lerchenberg 20 · 86923 Finning · Germany
SN	Serial number
REF	Order number
	The manufacturer declares the conformity of the device with the applicable European Regulations and Directives.
	Do not dispose of this device together with domestic waste! The device as a whole as well as any parts must be disposed of in accordance with WEEE Directive and national legislation.
	Caution, fragile! Handle with care!
	Protect against moisture! Store in a dry place.
	Temperature limit during storage
	Moisture limit during storage (non-condensing)
	Air pressure limit

Symbol	Meaning
STORAGE	Storage Conditions
TRANSPORT	Transport Conditions

Table 3: Symbols on Flow Meter, Sensors and Packaging

3 Description of the Measurement Principle

The function of the BioProTT™ FlowMCP and the BioProTT™ Clamp-On is based on an acoustic measurement principle and utilizes the transit time method to determine the flow. A typical transit time flow measurement system incorporates two piezo ceramics that act as both ultrasonic transmitter and receiver. The measurement system, consisting of a flow meter together with the BioProTT™ Clamp-On, operates by alternately transmitting and receiving an ultrasonic pulse between the two ceramics and measuring the transit time difference that it takes for the pulse to travel between them.

This method determines the transit time difference of ultrasonic signals through a measuring section and is used to estimate volumetric flow rates. There are at least two sound transducers required in order to send and receive ultrasonic pulses both in and against the flow direction. For a higher accuracy, our BioProTT™ Clamp-Ons incorporate two pairs of sound transducers, i.e. four piezo ceramics in total, which are arranged in an X-configuration around the tube containing the measured flow.

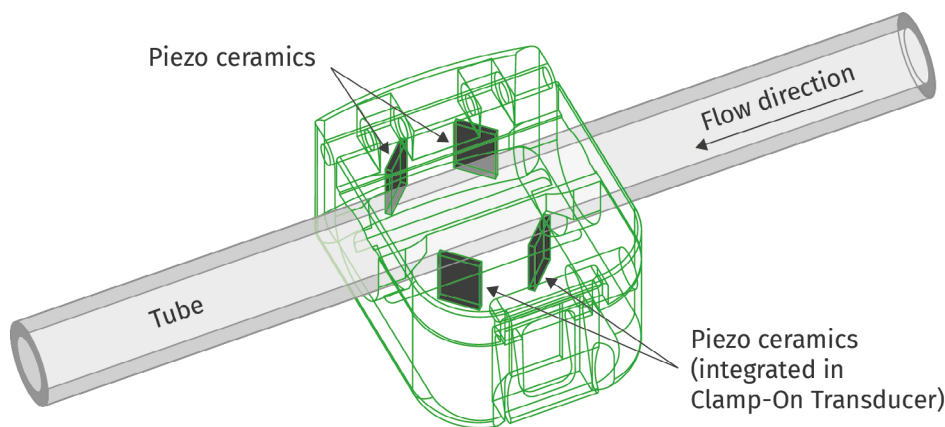

Figure 1: Sensor Structure

When sending ultrasonic signals through the measuring section, the transit time difference depends on the flow direction of the medium:

- If the ultrasonic sound signals are sent in the flow direction and volume flow of the medium, the downstream signal needs less time.
- If the ultrasonic sound signals are sent against the flow direction, the upstream signal needs more time

Consequently, the transit time difference is measured for every pulse. The difference between upstream and downstream measurements is proportional to the volumetric flow rate of the liquid in the tube. Therefore, by accurately measuring the difference between upstream and downstream transit time T_{up} and T_{down} , it is possible to determine the flow velocity.

4 Packaging Contents

The BioProTT™ FlowMCP is shipped with the following components:

BioProTT™ FlowMCP (1-4 channels)

BioProTT™ FlowMCP (Multi Channel Platform) supporting one, two, or four flow channels —depending on the ordered variant

Included (i.e. connected to the device) is one power supply connector.



BioProTT™ FlowMCP-a (1 or 2 channels)

BioProTT™ FlowMCP-a (Multi Channel Platform with analog interface) supporting one or two flow channels —depending on the ordered variant

Included (i.e. connected to the device) are

- one power supply connector and
- one analog connector



For a list of accessories and spare parts, please contact em-tec GmbH.

EN

5 Installation of the BioProTT™ FlowMeasurement System

The BioProTT™ FlowMeasurement System consists of the BioProTT™ FlowMCP (1-4 channels)/ BioProTT™ FlowMCP-a (1 or 2 channels), a BioProTT™ Clamp-On, and the corresponding cables.



- Compliance with the prescribed operating parameters and safety information must be ensured prior to the use of the device. The user is responsible for the integration of the device into their system, including the observation of safety aspects and electromagnetic compatibility.
- The following instructions must be strictly observed.

EN

5.1 Device Description: BioProTT™ FlowMCP (1-4 channels)

The image below shows the interfaces available for the BioProTT™ FlowMCP (1-4 channels):

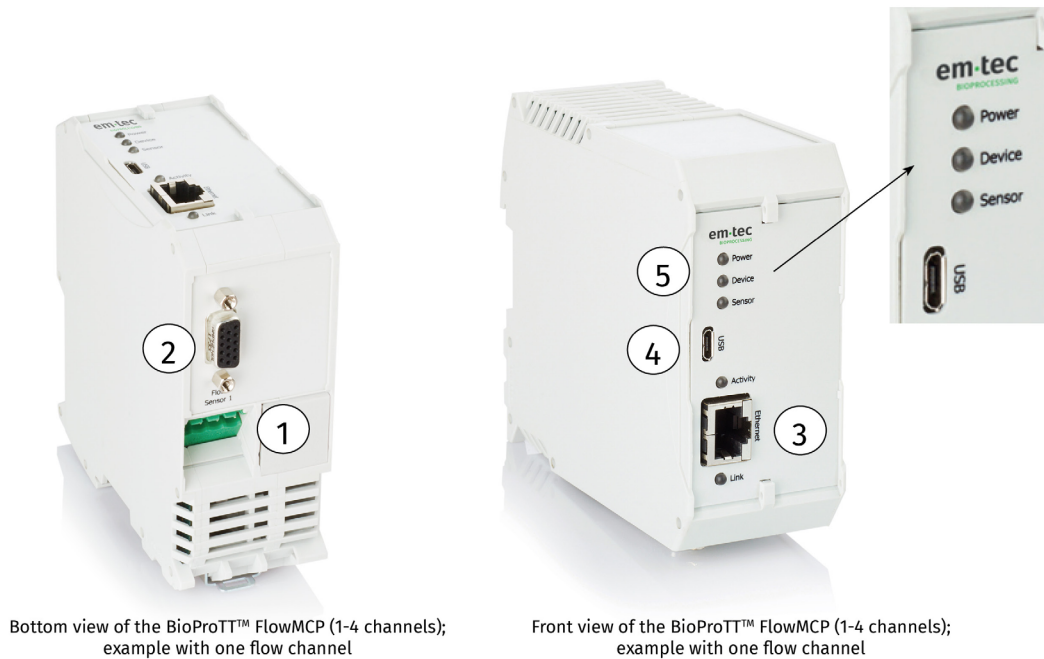

Figure 2: Device Description BioProTT™ FlowMCP (1-4 channels)

No	Components	Description
1	power supply	4-pin connecting socket for terminal block with PIN assignment as shown below
2	Sensor Connector #1-#4	D-Sub connection socket to connect the sensor to the extension cable
3	Ethernet connection	connector for Ethernet / LAN cable (Modbus TCP)
4	USB connection	USB for em-tec service purposes only





5	LEDs	LEDs for device status signalization	
		 Power	Lights: when power is connected Off: when no power is connected; if power supply fails or if the power supply is too low, refer to chapter 10 "Troubleshooting".
		 Device	Lights: when no device failure is present Blinking: when a device failure is present*
		 Sensor	Lights: when all sensors are connected Blinking: when a sensor is not connected or when a sensor failure is present*.The LED is also blinking if not all flow channels are connected to a sensor (e.g. only one sensor connected to BioProTT™ MCP 2)
		 Activity	Lights or blinking: Ethernet or Modbus TCP communication traffic present Off: no communication traffic present
		 Link	Lights: when Ethernet connection is present Off: no Ethernet connection is present
*for more details, refer to chapter 10 "Troubleshooting"			

Table 4-1: Components BioProTT™ FlowMCP (1-4 channels)

The PIN assignment on the power connection is as follows:

PIN Number	Meaning
1	+24 V DC, max. 2A
2	Ground
3	n/a
4	n/a

Table 4-2: Pin assignment terminal block

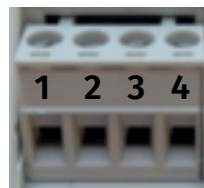
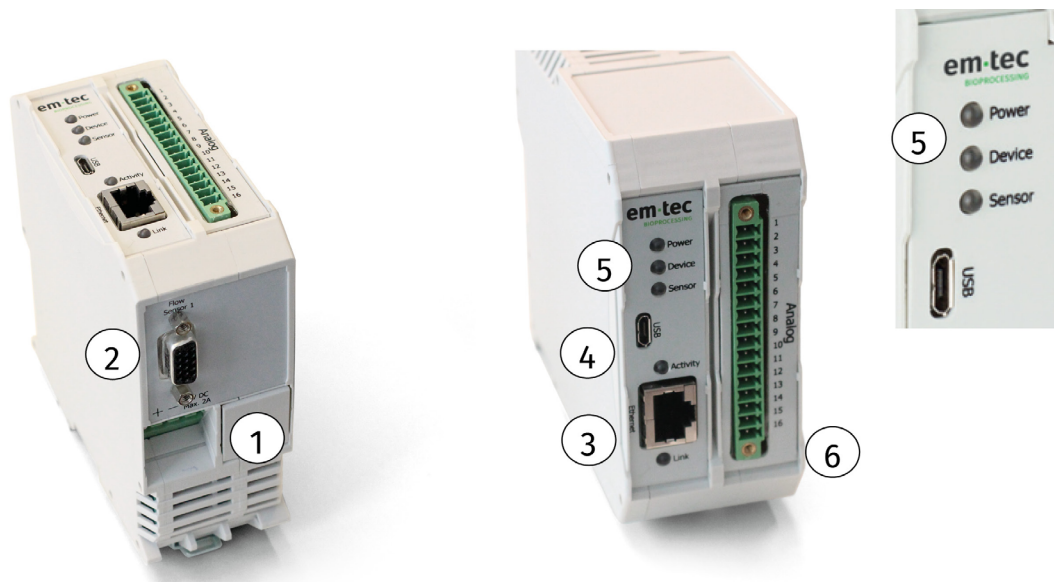

Figure 3: Terminal block

5.2 Device Description: BioProTT™ FlowMCP-a (1 or 2 channels)

The image below shows the interfaces available for the BioProTT™ FlowMCP-a (1 or 2 channels):



Bottom view of the BioProTT™ FlowMCP-a; example with one flow channel

Front view of the BioProTT™ FlowMCP-a; example with one flow channel

Figure 4: Device Description BioProTT™ FlowMCP-a

No	Components	Description
1	Power Supply	4-pin connecting socket for terminal block with PIN assignment as shown below
2	Sensor Connector #1-#2	D-Sub connection socket to connect the sensor to the extension cable
3	Ethernet connection	connector for Ethernet / LAN cable (Modbus TCP)
4	USB connection	USB for em-tec service purposes only
5	LEDs	LEDs for device status signalization
	Power	Lights: when power is connected Off: when no power is connected; if power supply fails or if the power supply is too low, refer to chapter 10 "Troubleshooting".
	Device	Lights: when no device failure is present Blinking: when a device failure is present*
	Sensor	Lights: when all sensors are connected Blinking: when a sensor is not connected or a sensor failure is present* The LED is also blinking if not all flow channels are connected to a sensor (e.g. only one sensor connected to BioProTT™ MCP 2-a)
	Activity	Lights or blinking: Ethernet or Modbus TCP communication traffic present Off: no communication traffic present
	Link	Lights: when Ethernet connection is present Off: no Ethernet connection is present
*for more details, refer to chapter 10 "Troubleshooting"		

EN

6	Terminal Block (analog signal)		Pin	Description
			1	RSS Channel 1 Current Loop +
			2	RSS Channel 1 Current Loop GND
			3	Flow Channel 1 Current Loop +
			4	Flow Channel 1 Current Loop GND
			5	RSS Channel 2 Current Loop + *
			6	RSS Channel 2 Current Loop GND *
			7	Flow Channel 2 Current Loop + *
			8	Flow Channel 2 Current Loop GND *
			9	Remote Zero Channel 1 +
			10	Remote Zero Channel 1 GND
			11	Remote Zero Channel 2 *
			12	Remote Zero Channel 2 GND *
			13	n/c
			14	n/c
			15	n/c
16	n/c			
*Only available for BioProTT™ FlowMCP 2-a				

Table 5-1: Components of BioProTT™ FlowMCP-a

The PIN assignment on the power connection is as follows:

PIN Number	Meaning
1	+24 V DC, max. 2A
2	Ground
3	n/a
4	n/a

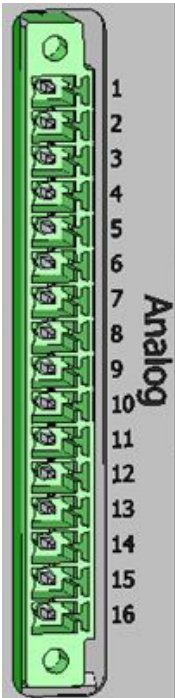
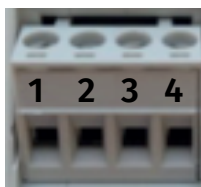

Figure 5: Terminal Block

Table 5-2: Pin assignment terminal block



The maximum resistance load on a current output must not exceed 560 Ω.

5.3 Installation of the BioProTT™ FlowMCP

The BioProTT™ FlowMCP supports DINrail mounting for the use in cabinets of process controls (IP20) and can thus be mounted only on a standard mounting channel (DIN-rail to EN 50022, TH 35/7,5 or TH 35/15). The mounting and the removal is the same for the BioProTT™ FlowMCP (1-4 channels) as it is for the BioProTT™ FlowMCP-a (1 or 2 channels).

5.3.1 Mounting

- Engage the module from the top in the top-hat rail and swivel it down so that the module slides into position.
- There is only one correct mounting position for the device. The sensor connections are on the device bottom.
- Please ensure that the BioProTT™ FlowMCP is firmly mounted onto the rail before setting up any connections.
- Other modules may be rowed up to the left and right of the device.
- There must be at least 5 cm clearance for heat dissipation above and below the module to ensure sufficient cooling of the device.
- The standard mounting channel must be connected to the equipotential bonding strip of the switch cabinet. **The connection wire must feature a cross-section of at least 10 mm².**



Figure 6: Assembly, mounted position

5.3.2 Removal

- To successfully remove the BioProTT™ FlowMCP, one needs a screwdriver with a 3-3.5 mm blade.
- First disconnect the power supply, the sensor, and the signal lines.
- Then disconnect and remove the sensor extension cables and the Ethernet connection and/or analog connection.
- Last, pull the DINrail fixing bracket downwards e.g. by using a screwdriver.



Figure 7: Disassembly

5.4 Powering of BioProTT™ FlowMCP



The terminal block requires a screwdriver with a 3.5 mm blade. The wires used in conjunction with the terminal block should not exceed 1.5 mm².

The BioProTT™ FlowMCP works with a 24V DC power, which has to be supplied from an external power supply (please see table 4-1 and 4-2 in chapter 5.1 and table 5-1 and 5-2 in chapter 5.2 for pin assignment).

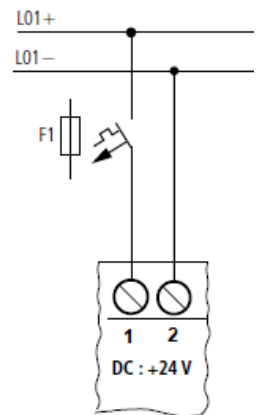

Figure 8: DC power supply to the device on terminal block



- The BioProTT™ FlowMCP needs to be connected to a limited energy circuit (24V DC with max. 2 A).
- The current needs to be limited by an overcurrent protection device of 2 A (slow). The overcurrent protection device shall be a fuse or a non-adjustable non-self-resetting electromechanical device (see F1 in Figure 8).

5.5 Connecting the BioProTT™ Clamp-On to the BioProTT™ FlowMCP

To connect the BioProTT™ Clamp-On to the BioProTT™ FlowMCP, carefully attach the 15-pin high density D-Sub socket to the sensor connection at the bottom of the BioProTT™ FlowMCP. Once this is done, the sensor can be connected to the extension cable before it is attached to the tube.



- The connector of the BioProTT™ Clamp-On must be dry when plugged in.
- While installing the BioProTT™ Clamp-On, be sure not to impair the function of the tubing system.
- Ensure that the tube size which is used corresponds with the size of the BioProTT™ Clamp-On.

5.6 Mounting and Installation of the BioProTT™ Clamp-On and the Extension Cables

The BioProTT™ FlowMCP includes sensor extension cables (ID13065) for the use inside the control cabinet with a length of max. 1.1 m.

The female plug of the sensor extension cable can be mounted on the cabinet wall with a thickness of up to 6.5 mm/ 0.26 inch (for panel cut-out refer to Figure 11).

It is important, that the device connection to the control cabinet wall is tight. The male plug (D-Sub) of the sensor extension cable is inserted in the sensor port of the BioProTT™ FlowMCP and needs to be secured by the screws. The cut-out panel with its dimensions and distances is indicated in Figure 11. The red marks on the socket and the plug indicate the correct orientation for inserting the plug.

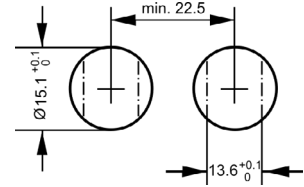

Figure 9: Panel cut out in cabinet; numbers refer to mm

EN



- It is recommended that only one extension cable is used when connecting a BioProTT™ Clamp-On.
- The total length of cable between sensor and flow meter must not exceed 4 m.

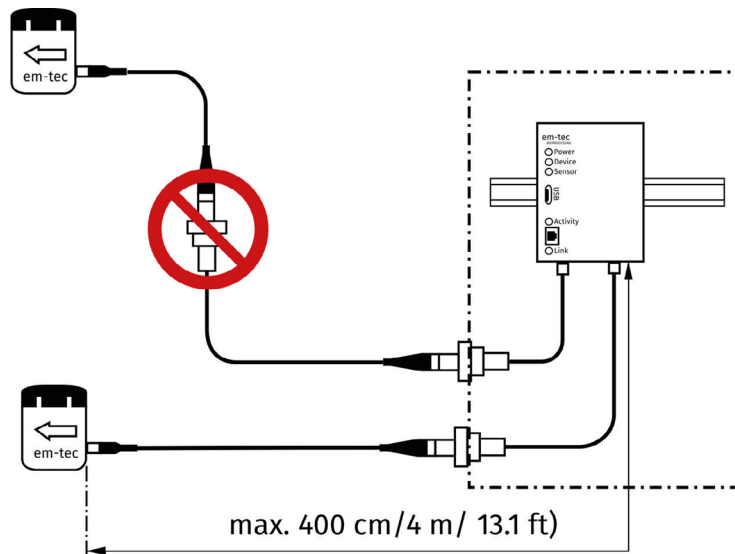

Figure 10: Cable Length and Connection

5.7 Line Routing, Shield and Measures to Combat Interference Voltage

This chapter deals with line routing in the case of bus, signal, and power supply lines, with the aim of ensuring an EMC-compliant design of your system.

5.7.1 General information on line routing

Inside and outside of cabinets:

In order to achieve an EMC-compliant routing of the lines, it is advisable to split the lines into the following line groups and to lay these groups separately.

- **Group A:**
 - general shielded bus and data lines (e. g. for Modbus TCP, Profibus DP, sensor extension cables, etc.)
 - general shielded analog lines
 - general unshielded lines for DC voltage ≤ 60 V
 - general unshielded lines for AC voltage ≤ 25 V
 - coaxial lines for monitors
- **Group B:**
 - general unshielded lines for DC voltage between 60 V and 400 V
 - general unshielded lines for AC voltage between 24 V and 400 V
- **Group C:**
 - general unshielded lines for DC voltages > 400 V

The table below allows you to read off the conditions for laying the line groups on the basis of the combination of the individual groups.

	Group A	Group B	Group C
Group A	1	2	3
Group B	2	1	3
Group C	3	3	1

Table 6: Line Routing

- 1 Lines may be laid in common bunches or cable ducts.
- 2 Lines must be laid in separate bunches or cable ducts (without minimum clearance).
- 3 Lines must be laid in separate bunches or cable ducts inside cabinets but on separate cable racks with at least 10 cm clearance outside of cabinets but inside buildings.

5.7.2 Shielding of lines

Shielding is intended to weaken (attenuate) magnetic, electrical or electromagnetic interference fields. Interference currents on cable shields are discharged to earth via the shielding bus which is connected conductively to the chassis or housing. A low-impedance connection to the PE wire is particularly important in order to prevent these interference currents from themselves becoming an interference source.

Wherever possible, use only lines with a braided shield. The coverage density of the shield should exceed 80 %. Avoid lines with foil shields since the foil can be damaged very easily as result of tensile and compressive stress on attachment. The consequence is a reduction in the shielding effect.

In general, you should always connect the shields of cables at both ends. The only way of achieving a good interference suppression in the higher frequency band is by connecting the shields at both ends.

Only in exceptional cases may the shield be connected at one end only. However, this then achieves only an attenuation of the lower frequencies.

Connecting the shield at one end may be more favorable if

- it is not possible to lay an equipotential bonding line
- analog signals (a few mV resp. mA) are to be transmitted
- foil shields (static shields) are used.

In the case of data lines for serial couplings, always use metallic or metallized plugs and connectors. Attach the shield of the data line to the plug or connector housing.

If there are potential differences between the earthing points, a compensating current may flow via the shield connected at both ends. In this case, you should lay an additional equipotential bonding line.

Please note the following points when shielding:

- Use metal cable clips to secure the shield braiding. The clips must surround the shield over a large area and must have adequate contact.
- Downstream of the entry point of the line into the cabinet, connect the shield to a shielding bus. Continue the shield as far as the module, but do not connect it again at this point!



Make sure that the grounding of your system complies with installation standards.

5.8 Attaching the BioProTT™ Clamp-On to the Tube

In order to be able to measure the flow inside the tube, the BioProTT™ Clamp-On must be clamped onto the tube. For more information regarding the BioProTT™ Clamp-On, please refer to the respective user manual.



- Before you clamp on the sensor, make sure that the tube is not deformed, damaged, or dirty.
- Air in the tube can lead to errors in the measurement or interrupt the acoustic coupling.
- Ensure that there is no residue or dirt in the flow channel.

First, make sure that the arrow on the lid aligns with the flow direction (positive flow display). Then, to clamp on the BioProTT™ Clamp-On, follow the steps illustrated below:

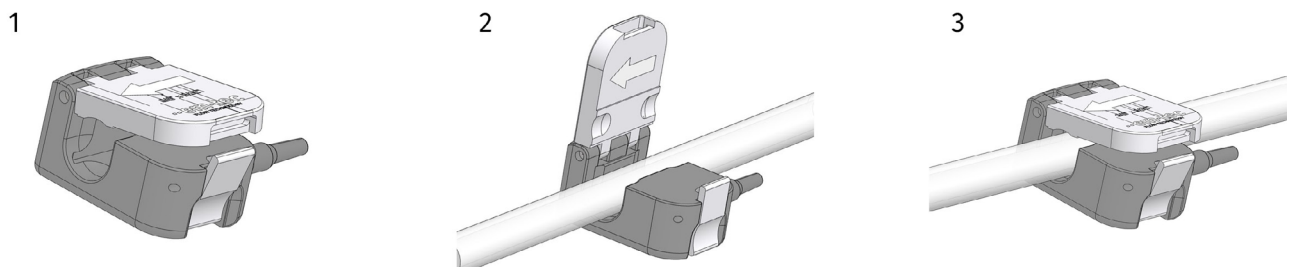

Figure 11: Attaching the BioProTT™ Clamp-On to the tube

1. Open the spring-loaded lock and swing back the lid.
2. Insert the tube into the channel.
3. Close the BioProTT™ Clamp-On lid and secure it with the help of the spring-loaded lock.



- To avoid flow turbulences and associated measurement inaccuracies, it is necessary for the tube to be straight in the area near the BioProTT™ Clamp-On.
- Do not use any force when closing the sensor lid; while the tube should be fixed within the channel, it must not be crammed into it as this might affect the measurement values or damage the sensor.
- Ensure that the lid is fully closed as to avoid fluctuating coupling and flow values.
- Ideally, the tube should be straight for a distance of 15 x the ID of the tube on either side of the sensor.

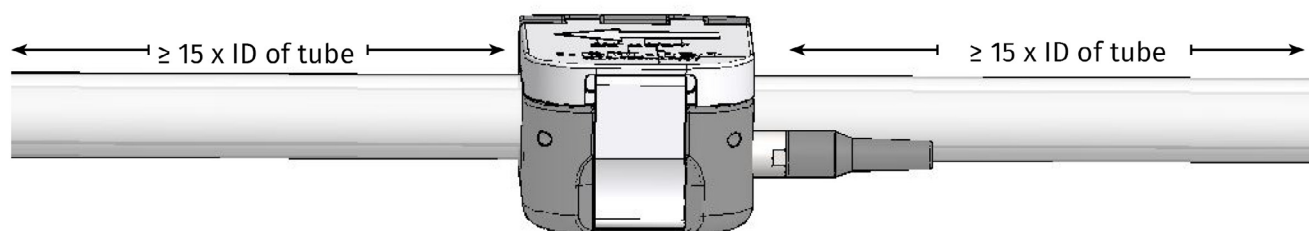

Figure 12: Distance on either side of the sensor

5.9 Use of the BioProTT™ Clamp-On

For further details concerning the use of the BioProTT™ Clamp-On , please refer to the user manual of the BioProTT™ Clamp-On, which is available from em-tec GmbH.



Make sure to follow the steps described below and to heed the warnings included in them in order to ensure the highest possible accuracy of measurement values.

Before starting the flow measurement:

1. Make sure that only tubes specified for the BioProTT™ Clamp-On are used as this is the tube type the BioProTT™ Clamp-On is adjusted and calibrated for.
2. Before each measurement, the cables, connectors and pins must be checked for breaks or damages as this could result in inaccurate or compromised measurements.
3. Ensure that the temperature of the medium is the one the BioProTT™ Clamp-On was adjusted and calibrated for.

Please note: Any changes in the medium itself or its temperature can cause errors or anomalies in the measurement

4. Ensure that no air bubbles are in the tube during the zero flow adjustment. Allow sufficient time for the system to adapt to ambient conditions, then zero the flow. Only then is the system ready for measurement.
5. The coupling must be checked before each measurement.
6. A zero flow adjustment must be carried out before each measurement to avoid possible offsets from the measured values.

Zero Flow Adjustment:

- The sensor must be clamped in the correct installation position at the location intended for it.
- The tube must be filled with liquid, but the liquid must not move.
 - Please note:** If the flow offset is too big (i.e. $\pm 3,000$ ml/min) a zero flow adjustment is not possible.
- Allow sufficient time for the system to adapt to ambient conditions.
- Ensure that no air bubbles are in the tube during the zero flow adjustment.
- The system is ready for measurement **only after** the zero flow adjustment was carried out.

During the flow measurement:

- Ensure that the coupling is within the operating range of 60 - 99 %. If the coupling falls below 50 %, the BioProTT™ FlowMCP issues a status change as the low coupling might impair the measurement. For more information regarding status information, please refer to chapter 10.2 "Status Information Troubleshooting".
- Any changes in the medium itself or its temperature can cause errors or anomalies in the measurement.
- While it is possible to carry out measurements outside of the specified flow range, em-tec GmbH cannot guarantee that resulting flow values will be within the given accuracy range.

The parameters of the connected BioProTT™ Clamp-On and the selected calibration table are displayed in the **sensor information page of the web interface** of the BioProTT™ FlowMCP.

For more information, refer to chapter 6 " Web Interface of the BioProTT™ FlowMCP".

5.10 Changing the BioProTT™ Clamp-On

If the BioProTT™ Clamp-On was exchanged before switching on the BioProTT™ FlowMCP, the new calibration parameters will be shown in the sensor information page of the web interface of the BioProTT™ FlowMCP after refreshing the page in the browser.

Please note: If the BioProTT™ Clamp-On is exchanged during the operation of the BioProTT™ FlowMCP, **another zero flow adjustment must be carried out** in order to ensure the highest possible accuracy.

5.11 Disassembly and Storage of the BioProTT™ Clamp-On



In order to not impair the measurement, it is best to always disconnect the BioProTT™ Clamp-On once the measurement process has been completed.

To disconnect the BioProTT™ Clamp-On, follow these steps:

1. Open the spring-loaded lock and swing back the lid.
2. Remove the tube from the channel.
3. Close the lid and unplug the sensor from the system.

Once you have disconnected the BioProTT™ Clamp-On, check for any residue of the medium or any other kind of dirt or grime and clean the sensor if necessary. Store the sensor according to storage specifications. Make sure to store it in a place where it cannot fall or be dropped and ensure that the plug is dry.

5.12 Cleaning and Disinfection of the BioProTT™ Clamp-On



Make sure no detergents or disinfectants leak into this device.

For the cleaning of the device, we recommend the use of common household detergents. In order to avoid stains and dirt from drying out, any residue should be removed after each application.

To clean the BioProTT™ Clamp-On, use a lint-free cloth. Be sure to remove any dirt in the clamping area. Additionally, please follow the legal regulations valid in your country.



- The BioProTT™ Clamp-On may not be submerged into cleaning or disinfecting solution.
- The BioProTT™ Clamp-On is not suited for cleaning processes using machines. Sterilization processes, especially steam sterilization or autoclaving, may not be used.

The following surface disinfectant is recommended:

Name	Manufacturer	Contact
Bacillot® AF	Hartmann	www.hartmann.de

5.13 Initialization and Start-Up of the BioProTT™ FlowMCP

When using a BioProTT™ FlowMCP 1 or 2 with analog interface, the flow as well as the RSS output of the analog output (for pinning refer to chapter 5.2 " Device Description: BioProTT™ FlowMCP-a (1 or 2 channels)") must be connected to a resistance of max. 560 Ohm. Alternatively, the device can be connected to an ampere meter before the power supply is attached to the device.

1. Connect a 24V DC power supply to the power connector as described in chapter 5.4.
2. Connect the em-tec sensors by using the extension cables as described in chapter 5.6.
3. Connect an Ethernet cable to the Ethernet socket to PC for configuration.

Note: The default IP address of the device is 192.168.0.12 and can be changed by using the set-up menu on the web interface (also refer to chapter 6.4).

4. After initializing the BioProTT™ FlowMCP, connect it to the Modbus TCP environment, e.g. the PLC.
5. Make sure to carry out a zero flow adjustment before starting the measurement.

Please note:

To zero the flow,

- the tube must be completely filled with liquid.
- there must be no air bubbles within the tube.
- the medium must not move.
- If the offset is too big (>3,000 ml/min), e.g. when the pump is still running or the medium is not yet completely still, a zero flow adjustment is not possible.



The analog interface should not be open when it is not in use. (e.g. when the BioProTT™ FlowMCP is connected to a current measurement system). During those times, the pins of the analog interface should be shorted.

6 Web Interface of the BioProTT™ FlowMCP



- The web interface only serves as a display and must not be used for the flow measurement itself.
- It can take some time for the web interface to fully load.
- **Please note:** It is the responsibility of the user to ensure IT security. em-tec GmbH is not responsible for any errors or inconsistencies in the measurement that result from a lack of security.

After an update, or upon the first start, the default IP address is 192.168.0.12. Please open this address in your web browser (Mozilla Firefox is preferred); the main page of the web interface will be open and show the information described in the following chapter.

6.1 Main Web Page for the BioProTT™ FlowMCP (1-4 channels)

The main page of the web interface of the BioProTT™ FlowMCP (1-4 channels) displays the following information:

em-tec ①
BIOPROCESSING

BioProTT™ FlowMCP Information

The web interface only serves as a display and cannot be used for the flow measurement.

Device state **Online** ②

Flow sensor ③	Sensor ④	Flow (ml/min) ⑤	RSS ⑥	Error. ⑦	Status. ⑧	Zero ⑨	Calib. Tbl ⑩	⑪
Flow Sensor 1	Connected	353	100%	0	1000	Not zeroed	Table 1 ▾	Zero Undo Zero
Flow Sensor 2	Disconnected	0	0%	0	8007	Not zeroed	Table 1 ▾	Zero Undo Zero

Sensor Information ⑫

Global Error for all Devices: 0000 ⑬

Reset global Error ⑭

Setup ⑮ Log Files ⑯

Build: SW Ver: 02.04.09.00; SVN Rev: 239298; Build Date: 2020/10/22 15:44:21 ⑰

www.em-tec.de ⑱

Figure 13: Main web page of web interface of BioProTT™ FlowMCP (1-4 channels)

No.	Description
1	Link to open the main page of the web interface (page shown)
2	Device connection to a PC: <ul style="list-style-type: none"> "green" indicating the BioProTT™ FlowMCP is connected to a PC "gray" indicating the BioProTT™ FlowMCP is not connected to a PC or that the data transfer from PC to BioProTT™ FlowMCP is not possible.
3	Number of available flow channels: <ul style="list-style-type: none"> "green" indicating the channel is available "gray" indicating the channel is not available
4	Connected Sensors: <ul style="list-style-type: none"> "green" indicating a sensor is connected "gray" indicating no sensor is connected
5	Flow value [ml/min] of the flow channel
6	RSS value [%] of the flow channel
7	Error present on the flow channel (displayed as decimal value). For more information, refer to chapter 10 "Troubleshooting".
8	Status of the flow channel (displayed as hexadecimal value). To receive additional information, move the mouse over the status information field and the current status will be displayed. For more information, refer to chapter 10 "Troubleshooting".
9	Information if sensor was zeroed or not
10	<p>Information about the selected sensor calibration table. In order to avoid unintentional changes of the calibration table, the user has to insert a password to proceed.</p> <p>To change the calibration table:</p> <ul style="list-style-type: none"> Select the drop-down menu. This automatically opens a pop-up window asking for the user name and password. The default user name is "root" and default password "unknown" (Please note: like "unknown" but without the "n"). Once the user name and password were inserted, the user can select "ok" to proceed, or "cancel" to stop the process and leave the calibration table unchanged. <div data-bbox="810 1608 1410 1778" data-label="Image"> </div> <p>Example only; look of actual window may vary.</p> <div data-bbox="288 1877 445 2033" data-label="Image"> </div> <p>Some web browsers automatically save the user name and password, even if they do not explicitly let users know that they do. If this is the case, the pop-up window asking for the user name and password only appears once—for the first action where it is needed—but after that all actions can be carried out without the user having to enter the user name or password.</p>



No.	Description
11	<p>Possibility to "zero" or to "undo zero" of the flow channel. Note: This is only possible if a sensor is connected.</p> <p>In order to avoid the flow being zeroed or the zeroing being undone unintentionally, the user has to insert a password to proceed.</p> <p>To "zero" or to "undo zero":</p> <ul style="list-style-type: none"> • Select the field for the desired action. • This automatically opens a pop-up window asking for the user name and password. • The default user name is "root" and default password "unknown" (Please note, like unknown" but without the "n"). • Once the user name and password were inserted, the user can select "ok" to proceed, or "cancel" to stop the process. <div data-bbox="858 613 1455 779" style="text-align: right;">  <p>Example only; look of actual window may vary.</p> </div> <div data-bbox="347 1032 507 1193" style="text-align: left;">  </div> <p>Some web browsers automatically save the user name and password, even if they do not explicitly let users know that they do. If this is the case, the pop-up window asking for the user name and password only appears once—for the first action where it is needed—but after that all actions can be carried out without the user having to enter the user name or password.</p>
12	<p>Possibility to open the sensor information page. For more information, refer to the description below.</p>
13	<p>Global device error (displayed as hexadecimal value). For more information, refer to chapter 10 "Troubleshooting".</p>
14	<p>Possibility to reset the global error</p>
15	<p>Possibility to open the set-up page. For more information, refer to the description below.</p>
16	<p>Possibility to open the device logging page. For more information, refer to the description below.</p>
17	<p>Software version of the BioProTT™ FlowMCP</p>
18	<p>Link to the em-tec website</p>

Table 7: Description of the main page of the web interface for the BioProTT™ FlowMCP (1-4 channels)

6.2 Main Web Page for the BioProTT™ FlowMCP-a

The analog interface is available for the BioProTT™ FlowMCP 1-a and the BioProTT™ FlowMCP 2-a only. Therefore, the analog interface is only displayed on the main page of the web interface if it is in fact available.

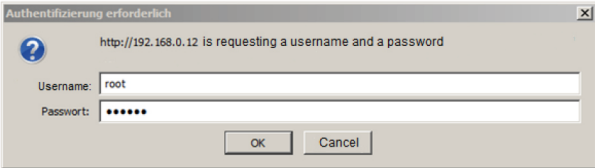
Please note: The Modbus TCP interface remains available even when the analog interface is used.

The main page of the web interface of the BioProTT™ FlowMCP-a displays the following information:

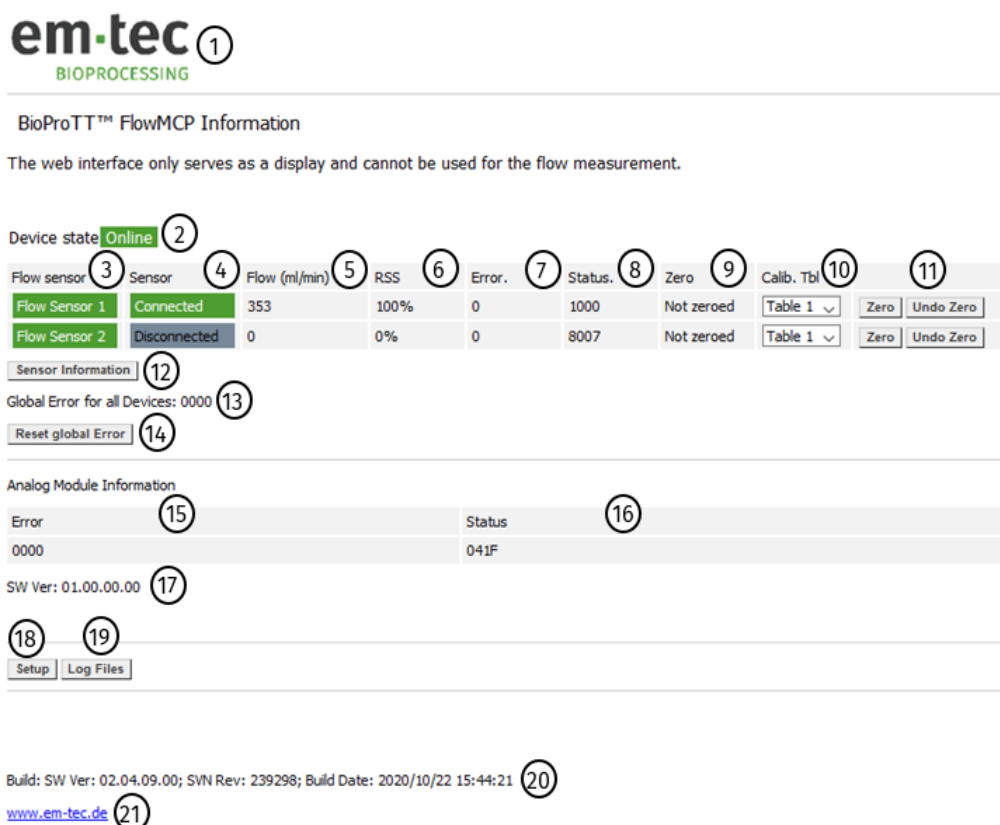



Figure 14: Main web page of web interface of BioProTT™ FlowMCP-a

No.	Description
1	Link to open the main page of the web interface (page shown)
2	Device connection to a PC: <ul style="list-style-type: none"> "green" indicating the BioProTT™ FlowMCP is connected to a PC "gray" indicating the BioProTT™ FlowMCP is not connected to a PC or that the data transfer from PC to BioProTT™ FlowMCP is not possible.
3	Number of available flow channels: <ul style="list-style-type: none"> "green" indicating the channel is available "gray" indicating the channel is not available
4	Connected Sensors: <ul style="list-style-type: none"> "green" indicating a sensor is connected "gray" indicating no sensor is connected
5	Flow value [ml/min] of the flow channel
6	RSS value [%] of the flow channel

No.	Description
7	Error present on the flow channel (displayed as decimal value). For more information, refer to chapter 10 "Troubleshooting".
8	Status of the flow channel (displayed as hexadecimal value). To receive additional information, move the mouse over the status information field and the current status will be displayed. For more information, refer to chapter 10 "Troubleshooting".
9	Information if sensor was zeroed or not
10	<p>Information about the selected sensor calibration table</p> <p>In order to avoid unintentional changes of the calibration table, the user has to insert a password to proceed.</p> <p>To change the calibration table:</p> <ul style="list-style-type: none"> • Select the drop-down menu. • This automatically opens a pop-up window asking for the user name and password. • The default user name is "root" and default password "unknown" (Please note, like unknown" but without the "n"). • Once the user name and password were inserted, the user can select "ok" to proceed, or "cancel" to stop the process and leave the calibration table unchanged. <div data-bbox="863 1037 1465 1205" style="border: 1px solid gray; padding: 5px; width: fit-content; margin: 10px auto;"> <p style="font-size: small; margin: 0;">Authentifizierung erforderlich</p> <p style="font-size: x-small; margin: 0;">http://192.168.0.12 is requesting a username and a password</p> <p style="margin: 0;">Username: <input type="text" value="root"/></p> <p style="margin: 0;">Passwort: <input type="password" value="*****"/></p> <p style="text-align: right; margin: 0;"> <input type="button" value="OK"/> <input type="button" value="Cancel"/> </p> </div> <p style="text-align: center; font-size: small; margin-top: 5px;">Example only; look of actual window may vary.</p>
	<div data-bbox="336 1294 507 1464" style="float: left; text-align: center; margin-right: 10px;">  </div> <p>Some web browsers automatically save the user name and password, even if they do not explicitly let users know that they do. If this is the case, the pop-up window asking for the user name and password only appears once—for the first action where it is needed—but after that all actions can be carried out without the user having to enter the user name or password.</p>

No.	Description
11	<p>Possibility to "zero" or to "undo zero" of the flow channel. Note: This is only possible if a sensor is connected.</p> <p>Possibility to "zero" or to "undo zero" of the flow channel. Note: This is only possible if a sensor is connected.</p> <p>In order to avoid the flow being zeroed or the zeroing being undone unintentionally, the user has to enter a password to proceed.</p> <p>To "zero" or to "undo zero":</p> <ul style="list-style-type: none"> • Select the field for the desired action. • This automatically opens a pop-up window asking for the user name and password. • The default user name is "root" and default password "unknown" <p>Please note, like unknown" but without the "n").</p> <ul style="list-style-type: none"> • Once the user name and password were inserted, the user can select "ok" to proceed, or "cancel" to stop the process. <div data-bbox="778 698 1385 869" data-label="Image"> </div> <p>Example only; look of actual window may vary.</p> <div data-bbox="274 1115 448 1290" data-label="Image"> </div> <p>Some web browsers automatically save the user name and password, even if they do not explicitly let users know that they do. If this is the case, the pop-up window asking for the user name and password only appears once—for the first action where it is needed—but after that all actions can be carried out without the user having to enter the user name or password.</p>
12	<p>Possibility to open the sensor information page. For more information, refer to the description below.</p>
13	<p>Global device error (displayed as hexadecimal value). For more information, refer to chapter 10 "Troubleshooting".</p>
14	<p>Possibility to reset the global error</p>
15	<p>Error of the analog interface (displayed as hexadecimal value). For more information, refer to chapter 10 "Troubleshooting".</p>
16	<p>Status information of the analog interface (displayed as hexadecimal value). For more information, please contact em-tec GmbH.</p>
17	<p>Software version of the analog interface</p>
18	<p>Possibility to open the set-up page. For more information, refer to the description below.</p>
19	<p>Possibility to open the device logging page. For more information, refer to the description below.</p>
20	<p>Software version of the BioProTT™ FlowMCP</p>
21	<p>Link to the em-tec website</p>

Table 8: Description of the main page of the web interface for the BioProTT™ FlowMCP-a

6.3 Sensor Information Page for the BioProTT™ FlowMCP

The sensor information page displays the following information:

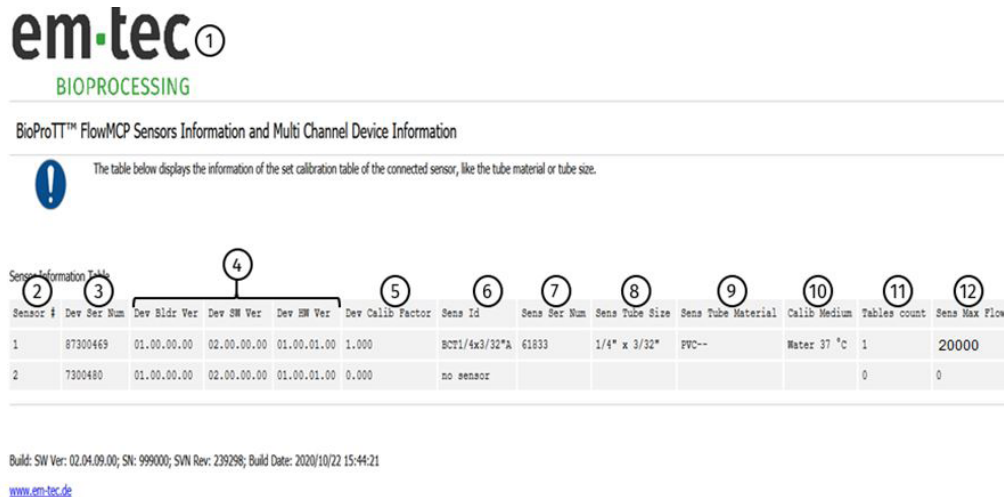

Figure 15: Sensor Information Page for the BioProTT™ FlowMCP

No.	Description
1	Link to open the main page of the web interface (page shown)
2	Number of the sensor (corresponds to the number of available flow channels)
3	Serial number of the flow measurement board inside the BioProTT™ FlowMCP. This information is important for service purposes.
4	Software version of the flow measurement board inside the BioProTT™ FlowMCP. This information is important for service purposes.
5	<p>Set calibration factor for the flow channel.</p> <ul style="list-style-type: none"> The set calibration factor is independent of the restart/reconnect behavior and independent of the connected sensor. Please explicitly check the calibration factor when <ul style="list-style-type: none"> a different calibration table is selected on the sensor a different sensor is connected to the same flow channel to ensure that the calibration factor is the right one for your current application. <p>For more information regarding the calibration factor setting, refer to the set-up page of the web interface. For more information regarding the calibration factor as such and how to determine it, please contact em-tec GmbH and ask for our Application Note about this subject.</p>
6	em-tec ID of the connected sensor
7	Serial number of the connected sensor
8	Tube size for the connected sensor
9	Tube material the connected sensor was calibrated and adjusted for and the set calibration table of the connected sensor

No.	Description
10	Medium the connected sensor was calibrated and adjusted for and the set calibration table of the connected sensor
11	Information regarding the set calibration table of the connected sensor
12	Maximal flow (Qmax) of the connected sensor and the set calibration table of the connected sensor

Table 9: Description of the sensor information page of the BioProTT™ FlowMCP

6.4 Set-Up Page of the BioProTT™ FlowMCP

The set-up page can be opened by clicking on the "setup" button on the main page. This opens a pop-up window. To log in at the set-up page, enter the default user name "root" and default password "uknown" (**Please note:** like "unknown" but **without** the "n").

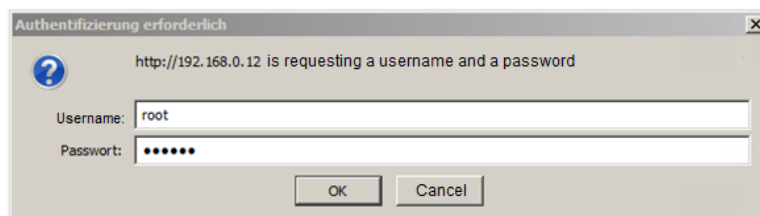

Figure 16: Set-Up Page Log-In

6.4.1 Set-Up Page for the BioProTT™ FlowMCP (1-4 channels)

em-tec BIOPROCESSING

BioProTT™ FlowMCP System Configuration

Network:

IP-Address:	192.168.0.12
Address Mask:	255.255.255.0
MODBUS Port number:	502

Miscellaneous:

Password:	*****
Device serial number:	111111
Device MAC address:	72-b4-d5-dd-10-00
Restore sensor settings after sensor reconnect / device restart:	<input checked="" type="checkbox"/> Keep sensor settings (calibration table, zero offset)
Clip RSS by 100%:	<input checked="" type="checkbox"/> clip it
Enable error filter and allow device to reset channels:	<input checked="" type="checkbox"/> Enable advanced error handling

	Flow Sensor 1	Flow Sensor 2
Calibration Factor: (0.5 - 1.5)	0.000	0.000

If a calibration factor has been entered for a specific flow sensor, please be aware that this factor has to be explicitly checked if e.g. a different table is selected on the same sensor.
Note: the set calibration factor is independent of the restart/reconnect behavior.



Previous settings will not be saved by the system. When changing the IP-Address, please review and note the set address before storing the setting. When the new IP-Address is stored, the device can only be connected under the new IP-Address.
Note: If the password or IP-Address are accidentally changed or lost, please contact em-tec GmbH.

In case of an error, the respective flow channel or analog board (if available) can be reset by pressing the reset button below. Before doing so, please check the system for failures, according to the troubleshooting in the MCP manual.

Reset Flow Sensor 1 Reset Flow Sensor 2

Figure 17: Set-Up page for the BioProTT™ FlowMCP (1-4 channels)

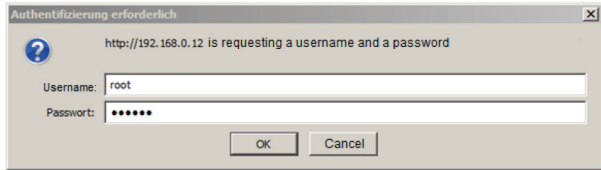
No.	Description
1	Link to open the main page of the web interface (see chapter 6.1)
2	<p>Device IP address. The IP address can be changed by adding the new address into this field and clicking the store* button.</p> <p>In order to avoid any unintentional changes of the IP address, the user has to enter a password to proceed.</p> <ul style="list-style-type: none"> Clicking into the field containing the IP address automatically opens a pop-up window. The default user name is "root". The default password is "unknown". <p>Please note: like "unknown" but without the "n".</p> <ul style="list-style-type: none"> To proceed with changing the IP address, select "ok", to stop the action and leave the IP address unchanged, select "Cancel". <div data-bbox="783 689 1385 860" data-label="Image"> </div> <p>Example only; look of actual window may vary.</p> <div data-bbox="277 1039 448 1205" data-label="Image"> </div> <p>Some web browsers automatically save the user name and password, even if they do not explicitly let users know that they do. If this is the case, the pop-up window asking for the user name and password only appears once—for the first action where it is needed—but after that all actions can be carried out without the user having to enter the user name or password.</p>
3	<p>Device IP-Address mask. The IP-Address mask can be changed by adding the new mask into this field and clicking the store* button.</p> <p>In order to avoid any unintentional changes of the IP address, mask the user has to enter a password to proceed.</p> <ul style="list-style-type: none"> Clicking into the field containing the address mask automatically opens a pop-up window. The default user name is "root". The default password is "unknown". <p>Please note: like "unknown" but without the "n".</p> <ul style="list-style-type: none"> To proceed with changing the IP address, select "ok", to stop the action and leave the IP address unchanged, select "Cancel". <div data-bbox="783 1496 1385 1666" data-label="Image"> </div> <p>Example only; look of actual window may vary.</p> <div data-bbox="277 1883 448 2049" data-label="Image"> </div> <p>Some web browser automatically save the user name and password, even if they do not explicitly let users know that they do. If this is the case, the pop-up window asking for the user name and password only appears once—for the first action where it is needed—but after that all actions can be carried out without the user having to enter the user name or password.</p>

No.	Description
4	<p>Device Modbus-Port. The Modbus-Port can be changed by adding the new port into this field and clicking the store* button.</p> <p>In order to avoid any unintentional changes of the Modbus port, the user has to enter a password to proceed.</p> <ul style="list-style-type: none"> Clicking into the field containing the address mask automatically opens a pop-up window. The default user name is "root". The default password is "uknown". <p>Please note: like "unknown" but without the "n".</p> <ul style="list-style-type: none"> To proceed with changing the IP address, select "ok", to stop the action and leave the IP address unchanged, select "Cancel". <div data-bbox="842 618 1445 786" style="text-align: right;">  <p>Example only; look of actual window may vary.</p> </div> <div data-bbox="336 987 507 1160" style="text-align: left;">  <p>Some web browsers automatically save the user name and password, even if they do not explicitly let users know that they do. If this is the case, the pop-up window asking for the user name and password only appears once—for the first action where it is needed—but after that all actions can be carried out without the user having to enter the user name or password.</p> </div>
5	<p>Password to open the setup page. The password can be changed by adding the new password into this field and clicking the store* button.</p> <div data-bbox="336 1323 507 1487" style="text-align: left;">  <ul style="list-style-type: none"> If the field with the password stays unchanged, the password will NOT be changed. Only if the field with the password changes can the new password be changed to the device. </div>
6	Serial number of the BioProTT™ FlowMCP (read-only field)
7	MAC address of the BioProTT™ FlowMCP (read-only field)
8	Possibility to keep sensor settings after a restart or reconnection of a sensor on a flow channel. This field is selected as default. When selected, the zero information and the selected calibration table of the sensor is stored for the respective flow channel so that after a power cycle or reconnection of a sensor, these settings are used.
9	Possibility to clip the RSS value to 100 %. This field is selected as default. When selected, the RSS value over Modbus TCP and in the web interface is clipped to 100 %. When not selected, values up to 133 % are possible.



No.	Description
10	<p>Possibility to set the Auto-Reset Function.</p> <p>If this is set, the BioProTT™ FlowMCP automatically resets the flow measurement board in an attempt to reset the error/warning when the error types/warnings affected by this are detected. The errors/warnings for which this is relevant are indicated by a "✓" in the table in chapter 10 "Troubleshooting").</p>
	 <p>During an automatic reset of the board, the measured flow value and/or the RSS value of the respective flow channels may go down to zero for a few seconds.</p>
	<p>For more information, refer to chapter 10 "Troubleshooting".</p>
11	<p>Possibility to set a calibration factor within the range of 0.5 to 1.5 for each channel.</p> <p>The set calibration factor is set for the flow channel. After a power cycle or connecting another sensor, the factor remains.</p> <p>For more information regarding the calibration factor as such and how to determine it, please contact em-tec GmbH and ask for our Application Note about this subject.</p>
12	<p>*Store button</p> <p>Clicking this button saves all performed changes on the set-up page.</p>
	 <ul style="list-style-type: none"> • Please note down the changed IP address, the changed IP address mask, the port and/or the changed password before clicking the store button. • Once the store button was pressed, the device can only be connected by using the new values. • If the set values are unknown, please contact the service department at em-tec GmbH.
13	<p>Possibility to reset all performed changes on the set-up page.</p> <p>Please note: This is only possible as long as the store button was not clicked.</p>
14	<p>Possibility to reset a flow channel.</p> <p>This can be used when e.g. an error on a flow channel is present and if this error should be reset.</p> <p>Before clicking reset, check the error according to the information given in chapter 10 "Troubleshooting".</p>

Table 10: Description of the set-up page of the BioProTT™ FlowMCP (1-4 channels)

6.4.2 Set-Up Page for the BioProTT™ FlowMCP-a

em-tec ①
BIOPROCESSING

BioProTT™ FlowMCP System Configuration

Network:

IP-Address: 192.168.0.12 ②
Address Mask: 255.255.255.0 ③
MODBUS Port number: 502 ④

Miscellaneous:

Password: ⑤
Device serial number: 988774 ⑥
Device MAC address: 70-b3-d5-d9-98-77 ⑦
Restore sensor settings after sensor reconnect / device restart: ⑧ Keep sensor settings (calibration table, zero offset)
Clip RSS by 100%: clip it ⑨
Enable error filter and allow device to reset channels: ⑩ Enable advanced error handling

⑪ Calibration Factor: (0.5 - 1.5)	Flow Sensor 1	Flow Sensor 2
	0.000	0.000

! If a calibration factor has been entered for a specific flow sensor, please be aware that this factor has to be explicitly checked if e.g. a different table is selected on the same sensor.
Note: the set calibration factor is independent of the restart/reconnect behavior.

Analog Board:

The update of the new settings after storing may take up to 10 seconds.

Enable/Disable Analog Output: Enabled Disabled ⑫
Flow to Current: 10Hz Flow Average | 1Hz Flow Average | 0.1Hz Flow Average | ⑬

Flow Sensor 1

Expand RSS range: On Off ⑭
Zero Flow adjustment over analog input: On Off ⑮
Flow value at 4 mA [ml/min] ⑯: 0
Flow value at 20 mA [ml/min] ⑰: 10000



! Previous settings will not be saved by the system. When changing the IP-Address, please review and note the set address before storing the setting. When the new IP-Address is stored, the device can only be connected under the new IP-Address.
Note: If the password or IP-Address are accidentally changed or lost, please contact em-tec GmbH.



⑱ Store ⑲ Reset

! In case of an error, the respective flow channel or analog board (if available) can be reset by pressing the reset button below. Before doing so, please check the system for failures, according to the troubleshooting in the MCP manual.

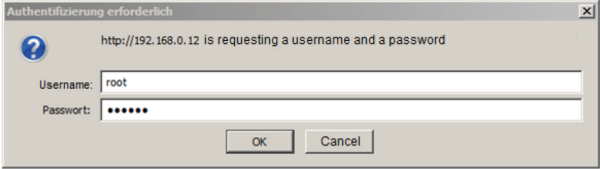
Reset Flow Sensor 1 ⑳ Reset Flow Sensor 2 ㉑ Reset AnalogBoard ㉒

Figure 18: Set-Up page of the BioProTT™ FlowMCP-a

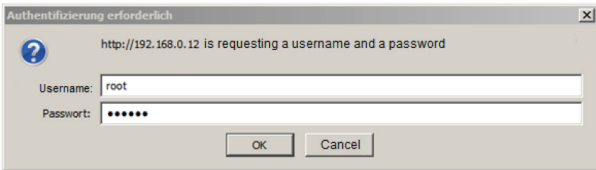
No.	Description
1	Link to open the main page of the web interface (see chapter 6.2)
2	<p>Device IP address. The IP address can be changed by adding the new address into this field and clicking the store* button.</p> <p>In order to avoid any unintentional changes of the IP address, the user has to enter a password to proceed.</p> <ul style="list-style-type: none"> Clicking into the field containing the IP address automatically opens a pop-up window. The default user name is "root". The default password is "unknown". Please note: like "unknown" but without the "n". To proceed with changing the IP address, select "ok", to stop the action and leave the IP address unchanged, select "Cancel". <div data-bbox="804 645 1406 813" style="text-align: center;">  <p>Example only; look of actual window may vary.</p> </div> <p> Some web browsers automatically save the user name and password, even if they do not explicitly let users know that they do. If this is the case, the pop-up window asking for the user name and password only appears once—for the first action where it is needed—but after that all actions can be carried out without the user having to enter the user name or password.</p>
3	<p>Device IP-Address mask. The IP-Address mask can be changed by adding the new mask into this field and clicking the store* button</p> <p>In order to avoid any unintentional changes of the IP address, mask the user has to enter a password to proceed.</p> <ul style="list-style-type: none"> Clicking into the field containing the address mask automatically opens a pop-up window. The default user name is "root". The default password is "unknown". Please note: like "unknown" but without the "n". To proceed with changing the IP address, select "ok", to stop the action and leave the IP address unchanged, select "Cancel". <p> Some web browsers automatically save the user name and password, even if they do not explicitly let users know that they do. If this is the case, the pop-up window asking for the user name and password only appears once—for the first action where it is needed—but after that all actions can be carried out without the user having to enter the user name or password.</p>

No.	Description
4	<p>Device Modbus-Port. The Modbus-Port can be changed by adding the new port into this field and clicking the store* button</p> <p>In order to avoid any unintentional changes of the Modbus port, the user has to enter a password to proceed.</p> <ul style="list-style-type: none"> Clicking into the field containing the address mask automatically opens a pop-up window. The default user name is "root". The default password is "unknown". Please note: like "unknown" but without the "n". To proceed with changing the IP address, select "ok", to stop the action and leave the IP address unchanged, select "Cancel".  <p>Example only; look of actual window may vary.</p>
	 <p>Some web browsers automatically save the user name and password, even if they do not explicitly let users know that they do. If this is the case, the pop-up window asking for the user name and password only appears once—for the first action where it is needed—but after that all actions can be carried out without the user having to enter the user name or password.</p>
5	<p>Password to open the setup page. The password can be changed by adding the new password into this field and clicking the store* button</p>  <ul style="list-style-type: none"> If the field with the password stays unchanged, the password will not be changed. Only if the field with the password changes can the new password be changed on the device.
6	Serial number of the BioProTT™ FlowMCP (read-only field)
7	MAC address of the BioProTT™ FlowMCP (read-only field)
8	Possibility to keep sensor settings after a restart or reconnection of a sensor on a flow channel. This field is selected as default. When selected, the zero information and the selected calibration table of the sensor is stored for the respective flow channel so that after a power cycle or reconnection of a sensor, these settings are used.
9	<p>Possibility to clip the RSS value to 100 %. This field is selected as default. When selected, the RSS value over Modbus TCP and in the web interface is clipped to 100 %. When not selected, values up to 133 % are possible.</p> <p>Please note: This setting only affects the RSS value given out through the Modbus-TCP interface; the RSS value over the analog interface is not affected by this setting</p>

No.	Description
10	Possibility to set the Auto-Reset Function.. If this is set, the BioProTT™ FlowMCP automatically resets the flow measurement board when detecting certain error types/warnings (the error types/warnings affected by this are indicated by a "✓" in the table in chapter 10 "Troubleshooting").
	 <p data-bbox="491 562 1418 674">During an automatic reset of the board, the measured flow value and/or the RSS value of the respective flow channels may go down to zero for a few seconds.</p>
	For more information, refer to chapter 10 "Troubleshooting".
11	Possibility to set a calibration factor within the range of 0.5 to 1.5 for each channel. The set calibration factor is set for the flow channel and thus affects the values on both the digital as well as the analog interface. After a power cycle or connecting another sensor, the factor remains. For more information regarding the calibration factor as such and how to determine it, please contact em-tec GmbH and ask for our Application Note about this subject.
12	Possibility to disable the analog interface. After every device start, the analog interface is enabled. Only when the device is in running mode, can the analog interface be disabled.
13	Possibility to set the flow average for the analog interface. Per default, this value is set to a flow average of 1 Hz.
14	Possibility to change the RSS range for the analog output. Per default, this is set to "off". When set to "off", the analog output of 4-20 mA corresponds to a RSS value of 0 - 100 %. Please note: This setting only affects the analog interface . When set to "on", the analog output of 4 mA - 20 mA corresponds to a RSS value of 0-133 %.
15	Possibility to allow the undo-zeroing function over the analog interface. Per default, this is set to "off". → When set to "off", a current increase from 4 mA - 8 mA to 12 mA - 20 mA effects a zero flow adjustment of the respective flow channel. A current decrease has no effect. → When set to "on", a current increase from 4 mA - 8 mA to 12 mA - 20 mA effects a zero flow adjustment of the respective flow channel while a current decrease from 12 mA - 20 mA to 4 mA - 8 mA effects a resetting of the zero flow adjustment on the respective flow channel. Please note: The main reason for setting this function to "on" is to find out the offset of the connected sensor.



No.	Description
16	<p>Possibility to set the flow value for 4 mA of the analog interface. Per default, this is set to 0. When set to 0, a current of 4 mA corresponds to a flow value of 0 ml/min. The setting is stored for the connected sensor. In total, the current output for 16 different sensors can be stored.</p> <p>Please note: During the initial connection of a sensor, the first calibration table (Table 1) is selected and there is no offset stored.</p>
	 <p>Settings must not be set outside the specified range of the connected sensor</p>
17	<p>Possibility to set the flow value for 20 mA of the analog interface. Per default, this is set to the Qmax of the connected sensor. When set to e.g. to 10000, a current of 20 mA corresponds to a flow of 10,000 ml/min. The setting is stored for the connected sensor. In total, the current output for 16 different sensors can be stored.</p> <p>Please note: During the initial connection of a sensor, the first calibration table (Table 1) is selected and there is no offset stored.</p>
18	<p>*Store button Clicking this button saves all performed changes on the set-up page.</p>
	 <ul style="list-style-type: none"> • Please note down the changed IP address, the changed IP address mask, the port and/or the changed password before clicking the store button. • Once the store button was selected, the device can only be connected by using the new values. • If the set values are unknown, please contact the service department of em-tec GmbH. • Make sure to not change any of the values to values outside of the specified range for either the BioProTT™ FlowMCP or the connected BioProTT™ Clamp-On.
19	<p>Possibility to reset all performed changes on the set-up page. Please note: This is only possible as long as the store button was not selected.</p>
20	<p>Possibility to reset a flow channel. This can be used when e.g. an error on a flow channel is present and if this error should be reset. Before clicking reset, check the error according to the information given in chapter 10 "Troubleshooting".</p>
21	<p>Possibility to reset the analog interface PCB. This can be used when, e.g. an error is present on an analog interface PCB and if this error should be reset. Before clicking reset, check the error according to the information given in chapter 10 "Troubleshooting".</p>

Table 11: Description of the set-up page of the BioProTT™ FlowMCP-a

6.5 Logging Page of the BioProTT™ FlowMCP



BioProTT™ FlowMCP System Log Files



Below, all log-files created since the first device start are present. For each hour since the first device start, a separate log file is present if an event, warning or error occurred during that hour. For detailed information about the logging, please contact em-tec.

- [1.log \(1910 B\)](#)
- [2.log \(38 B\)](#)
- [3.log \(1312 B\)](#)
- [4.log \(552 B\)](#)
- [6.log \(37 B\)](#)
- [7.log \(38 B\)](#)
- [10.log \(7073 B\)](#)
- [11.log \(9628 B\)](#)
- [12.log \(14193 B\)](#)
- [13.log \(10474 B\)](#)



www.em-tec.de

EN

Figure 19: Logging page of the BioProTT™ FlowMCP

No.	Description
1	Link to open the main page of the web interface
2	<p>Available log files of the BioProTT™ FlowMCP.</p> <p>For every hour the device is running, a new log file will be created as long as a logging was present.</p> <p>The log files are important for the service department of em-tec GmbH. If you contact our service department and are asked for the log files, the files can be downloaded by clicking on the relevant files. Once downloaded, the file can be sent to em-tec GmbH.</p> <p>Please note: While downloading the log files does not usually influence the flow measurement, we nevertheless advise against a download during the running process.</p>
3	Possibility to switch to the first logging page containing 10 log files.
4	Possibility to switch to the previous logging page containing 10 log files.
5	Possibility to switch to the next logging page containing 10 log files.
6	Possibility to switch to the last logging page containing 10 log files.

Table 12: Description of the logging page of the BioProTT™ FlowMCP

7 Modbus Interface

Supported Modbus functions and mapping of the internal registers to the Modbus registers/coils/inputs numbers:

7.1 Read Input Register (Function Code: 0x04)

Register Index	Register Name	Description	Parameter / Range
Flow Channel 1			
0	REG_RSS	16 bit word of coupling, channel 1	0..100 (default range) in [%]
1	REG_FLOW_SLOW_HI,	High 16 bit word of flow value averaged over the last 1s, channel 1	-999999 ... +999999 (the actual Qmax depends on the connected sensor)
2	REG_FLOW_SLOW_LO,	Low 16 bit word of flow value averaged over the last 1s, channel 1	
3	REG_FLOW_FAST_HI,	High 16 bit word of flow value averaged over the last 0.1s, channel 1	-999999 ... +999999 (the actual Qmax depends on the connected sensor)
4	REG_FLOW_FAST_LO,	Low 16 bit word of flow value averaged over the last 0.1s, channel 1	
5	REG_ERROR,	16 bit word of error code, channel 1; as hexadecimal value	See chapter 10 "Troubleshooting" for more information. 0x0000 means no error/warning
6	REG_R_TABLE,	16 bit word of current calibration table, channel 1	1 ... 7
Flow Channel 2			
7	REG_RSS,	See channel 1	
8	REG_FLOW_SLOW_HI,		
9	REG_FLOW_SLOW_LO,		
10	REG_FLOW_FAST_HI,		
11	REG_FLOW_FAST_LO,		
12	REG_ERROR,		
13	REG_R_TABLE,		
Flow Channel 3			
14	REG_RSS,	See channel 1	
15	REG_FLOW_SLOW_HI,		
16	REG_FLOW_SLOW_LO,		
17	REG_FLOW_FAST_HI,		
18	REG_FLOW_FAST_LO,		
19	REG_ERROR,		
20	REG_R_TABLE,		

Register Index	Register Name	Description	Parameter / Range
Flow Channel 4			
21	REG_RSS,	See channel 1	
22	REG_FLOW_SLOW_HI,		
23	REG_FLOW_SLOW_LO,		
24	REG_FLOW_FAST_HI,		
25	REG_FLOW_FAST_LO,		
26	REG_ERROR,		
27	REG_R_TABLE,		
Device Information			
56	REG_IP_ADDR_1	IP Address 1 (192.168.000.012)	0 .. 255
57	REG_IP_ADDR_2	IP Address 2 (192. 168 .000.012)	0 .. 255
58	REG_IP_ADDR_3	IP Address 3 (192.168. 000 .012)	0 .. 255
59	REG_IP_ADDR_4	IP Address 4 (192.168.000. 012)	0 .. 255
60	REG_IP_MASK_1	IP Addr Mask 1 255.255.255.000	0 .. 255
61	REG_IP_MASK_2	IP Addr Mask 2 255. 255 .255.000	0 .. 255
62	REG_IP_MASK_3	IP Addr Mask 3 255.255. 255 .000	0 .. 255
63	REG_IP_MASK_4	IP Addr Mask 4 255.255.255. 000	0 .. 255
64	REG_IP_PORT_NUM	Port number 502	0 .. 65535

Table 13: Read input register

7.1.1 Additional Information Regarding the Read Input Register (Function Code: 0x04)

Register Index	Register Name	Description	Parameter / Range
65	REG_STATUS	16 bit word of status information, channel 1, as bit-coded value	Contains different flags representing the status of the channel. For more information, see status list in chapter 10 "Troubleshooting"
66	REG_STATUS	16 bit word of status information, channel 2, as bit-coded value	See above
67	REG_STATUS	16 bit word of status information, channel 3, as bit-coded value	See above
68	REG_STATUS	16 bit word of status information, channel 4, as bit-coded value	See above
73	REG_SENS_MAX_FLOW_HI	High 16 bit word of sensor max flow (Qmax), channel 1	-999999...+999999 (the actual Qmax depends on the connected sensor)
74	REG_SENS_MAX_FLOW_LO	High 16 bit word of sensor max flow (Qmax), channel 1	

Register Index	Register Name	Description	Parameter / Range
75	REG_SENS_MAX_FLOW_HI	High 16 bit word of sensor max flow (Qmax), channel 2	See above
76	REG_SENS_MAX_FLOW_LO	High 16 bit word of sensor max flow (Qmax), channel 2	
77	REG_SENS_MAX_FLOW_HI	High 16 bit word of sensor max flow (Qmax), channel 3	See above
78	REG_SENS_MAX_FLOW_LO,	High 16 bit word of sensor max flow (Qmax), channel 3	
79	REG_SENS_MAX_FLOW_HI	High 16 bit word of sensor max flow (Qmax), channel 4	See above
80	REG_SENS_MAX_FLOW_LO	High 16 bit word of sensor max flow (Qmax), channel 4	
89	REG_TABLE_COUNT	Amount of calibration tables on the sensor connected to channel 1	1...7, depends on the connected sensor
90	REG_TABLE_COUNT	Amount of calibration tables on the sensor connected to channel 2	See above
91	REG_TABLE_COUNT	Amount of calibration tables on the sensor connected to channel 3	See above
92	REG_TABLE_COUNT	Amount of calibration tables on the sensor connected to channel 4	See above
97	REG_DEVICES_GLOBAL_ERROR	Global errors of the BioProTT™ FlowMCP, as hexadecimal value	Contains the global BioProTT™ FlowMCP device error. For more information, see chapter 10 "Troubleshooting". 0x0000 means no global error present
98	REG_SENS_SERIAL_HI	High 16 bit word of sensor serial number channel 1	0...999999
99	REG_SENS_SERIAL_LO	Low 16 bit word of sensor serial number channel 1	
100	REG_SENS_SERIAL_HI	High 16 bit word of sensor serial number channel 2	See above
101	REG_SENS_SERIAL_LO	Low 16 bit word of sensor serial number channel 2	
102	REG_SENS_SERIAL_HI	High 16 bit word of sensor serial number channel 3	See above
103	REG_SENS_SERIAL_LO	Low 16 bit word of sensor serial number channel 3	
104	REG_SENS_SERIAL_HI	High 16 bit word of sensor serial number channel 4	See above
105	REG_SENS_SERIAL_LO	Low 16 bit word of sensor serial number channel 4	

Table 14: Additional Information

7.2 Read Discrete Inputs (Function Code: 0x02)

Register Index	Register Name	Description	Parameter / Range
Sensor Connect Information			
0	REG_SENS_CONNECT	connection state of sensor on channel 1	0 = sensor disconnected 1 = sensor connected
1	REG_SENS_CONNECT	connection state of sensor on channel 2	
2	REG_SENS_CONNECT	connection state of sensor on channel 3	...
3	REG_SENS_CONNECT	connection state of sensor on channel 4	...
Flow Channel Availability Information			
8	REG_DEV_AVAILABLE	Channel 1 availability	0 = channel is offline; i.e. no data can be received from this flow channel 1 = channel is online and data is received from it
9	REG_DEV_AVAILABLE	Channel 2 availability	...
10	REG_DEV_AVAILABLE	Channel 3 availability	...
11	REG_DEV_AVAILABLE	Channel 4 availability	...

Table 15: Read discrete inputs

7.3 Write Coil (Function Code: 0x05)

Register Index	Register Name	Description	Parameter / Range
Zero setting of flow sensor			
0	REG_W_ZERO	Set zero on channel 1	1 = set zero 0 = unset zero
1	REG_W_ZERO	Set zero on channel 2	...
2	REG_W_ZERO	Set zero on channel 3	...
3	REG_W_ZERO	Set zero on channel 4	...
Reset Flow Channel			
8	REG_W_RESET	Reset channel 1	Set from 0 to 1 = reset flow channel. Note: in a failure situation on the flow channel such as a flow channel error, a failure can be reset by resetting the flow channel. Before doing so, check the device in regard to the reported error listed in the troubleshooting.
9	REG_W_RESET	Reset channel 2	...
10	REG_W_RESET	Reset channel 3	...
11	REG_W_RESET	Reset channel 4	...

Register Index	Register Name	Description	Parameter / Range
Reset Global Error			
16	REG_W_RESET_GLOBAL_ERROR	Reset global error on device	Set from 0 to 1 = reset global error. Note: if a global error occurs on the device, it can be reset. Before doing so, check the device in regard to the reported error listed in the troubleshooting.

Table 16: Write coil

Please note:

This is a bit register. Some PLCs only accept a bit-by-bit input; i.e., if several bits are set at once, it might happen that the PLC switches to another function code.

- As there is no other function code available for the BioProTT™ FlowMCP, if several bits are set at once, nothing happens.
- To ensure that the desired command is carried out, set the bits one-by-one.

7.4 Read Coil (Function Code: 0x01)

Register Index	Register Name	Description	Parameter / Range
Flow sensor zero information			
0	REG_R_ZERO	Set zero on channel 1	0 = zero is not set 1 = zero is set
1	REG_R_ZERO	Set zero on channel 2	...
2	REG_R_ZERO	Set zero on channel 3	...
3	REG_R_ZERO	Set zero on channel 4	...

Table 17: Read coil

7.5 Write Register (Function Code: 0x06)

Register Index	Register Name	Description	Parameter / Range
Set flow sensor calibration table			
0	REG_W_TABLE	Set calibration table on channel 1, 1 indicates the first calibration table	1.. 7
1	REG_W_TABLE	Set calibration table on channel 2	...
2	REG_W_TABLE	Set calibration table on channel 3	...
3	REG_W_TABLE	Set calibration table on channel 4	...

Table 18: Write register

For performance reasons, it is recommended to bundle the reading of input registers per item as follows:

Flow channel 1:

(0 REG_RSS, 1 REG_FLOW_SLOW_HI, 2 REG_FLOW_SLOW_LO, 3 REG_FLOW_FAST_HI, 4 REG_FLOW_FAST_LO, 5 REG_ERROR, 6 REG_R_TABLE)

Flow channel 2:

(7 REG_RSS, 8 REG_FLOW_SLOW_HI, 9 REG_FLOW_SLOW_LO, 10 REG_FLOW_FAST_HI, 11 REG_FLOW_FAST_LO, 12 REG_ERROR, 13 REG_R_TABLE) ... and so on.

8 Analog Interface

8.1 Measurement Using the Analog Interface of the BioProTT™ FlowMCP-a

The BioProTT™ FlowMCP-a can be connected to a data acquisition or process control system via the analog interface. The BioProTT™ FlowMCP 1-a comes with two analog output interfaces, the BioProTT™ FlowMCP 2-a with four, that are used to transmit the flow and RSS (acoustic coupling) values. The values are transmitted within the range of (0)4 mA - 20 mA.

Additionally, the BioProTT™ FlowMCP 1-a has one, the BioProTT™ FlowMCP 2-a two, analog interface(s) to perform a zero flow adjustment of the connected sensor.



- A current of 0 mA indicates a broken cable, circuit, or power leakage and must be checked before proceeding with the application.
- The RSS value should be $\geq 50\%$, or ≥ 12.0 mA. This indicates a good signal and is important for an accurate flow measurement.
- If the tube is too small or the sensor is too large, if there is no liquid or bubbles inside the tubing, this can also impact the coupling and lead to the RSS value being insufficient.
- Ensure that the tube fits the sensor you are using.
- Also follow the instructions described in chapter 5.5 "Connecting the BioProTT™ Clamp-On to the BioProTT™ FlowMCP".

8.1.1 RSS (Coupling) via the Analog Interface

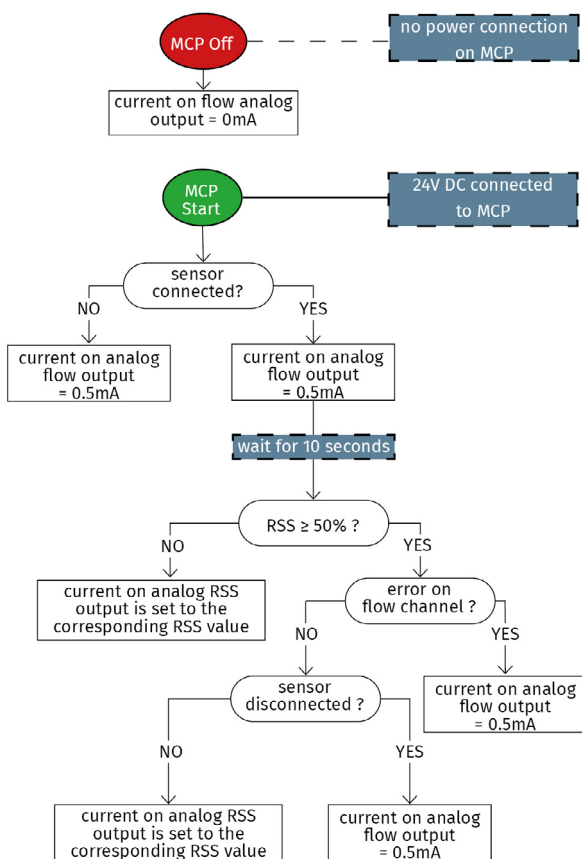

The software maps the RSS value from 0 - 100 % (0 - 133 % when 'Expand RSS range' is set to 'On' on the web interface) linearly to 4 mA - 20 mA. The current output for the RSS value can be read as follows:

- 0 mA indicates a broken cable, circuit, or power leakage
- currents of 0.5 mA indicate an error or an invalid sensor or a sensor that has not yet been recognized (for more information, refer to chapter 10 "Troubleshooting").
- 4 mA equals 0 % RSS/coupling (no signal)
- 20 mA equals 100 % RSS (or 133 %, depending on the setting).

Figure 20: Flow chart RSS on analog output

8.1.2 Flow Value via the Analog Interface

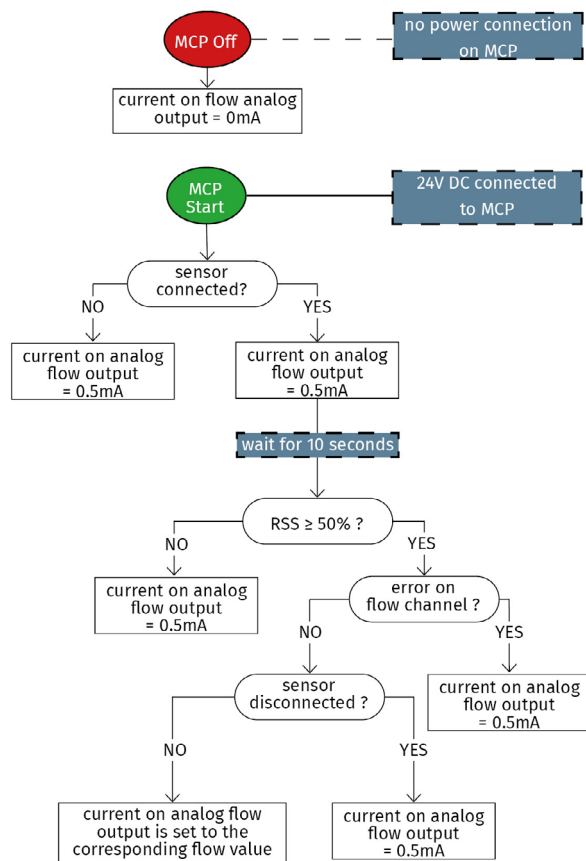

Figure 21: Flow chart flow on analog output

Please note:

This means, that the flow value within the range of 1 mA to <4 mA can also be negative in case the flow value at 4 mA was set to "0".

- 4 mA equals the flow value set for the parameter "flow value at 4 mA" on the web interface
- 20 mA equals the flow value set for the parameter "flow value at 20 mA" on the web interface

The default settings for "flow value at 4 mA" and "flow value at 20 mA" upon first connecting a sensor are:

- 0 for "flow value at 4 mA"
- Qmax of the connected sensor for "flow value at 20 mA"

When another sensor is connected to the flow channel for the first time, the Qmax of the new sensor is used as "flow value at 20 mA".

It is possible to store the settings for "flow value at 4 mA" and "flow value at 20 mA" for a total of 16 different sensors on the BioProTT™ FlowMCP.

The internal software of the BioProTT™ FlowMCP-a maps the flow value from the flow value set at 4 mA to the flow value set at 20 mA (both can be set on the web interface) linearly to 4 mA - 20 mA. The current output of the flow value can be read as follows:

- 0 mA indicates a broken cable, circuit, or power leakage
- currents of 0.5 mA indicate invalid flow conditions such as, e.g. low coupling or an error condition like an invalid sensor or a sensor that has not yet been recognized (for more information, refer to chapter 10 "Troubleshooting").
- the value for the range between 1 mA to <4 mA depends on the value set for 4 mA on the web interface (see no. 15 in chapter 6.4.2 "Set-Up Page of the BioProTT™ FlowMCP-a") as the graph (compare Figure 23) is a linear continuation of the graph between 4 mA to 20 mA.

The following figure shows the flow rate versus the output current:

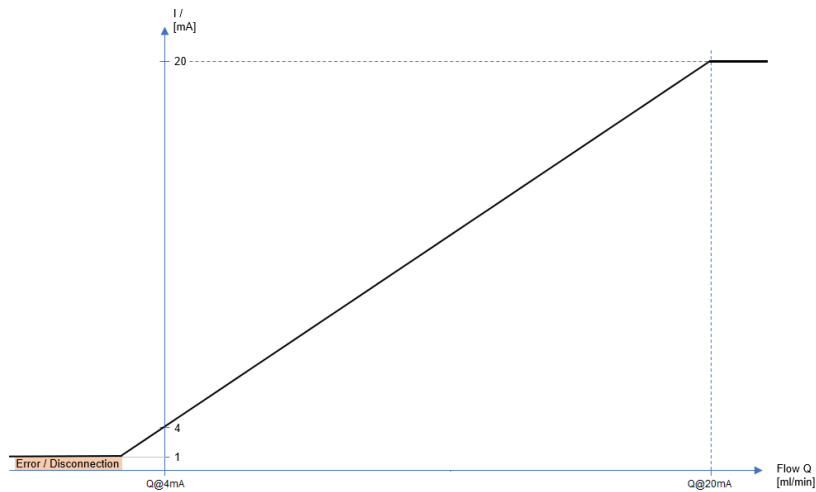

Figure 22: Flow rate vs. output current

To determine the flow value based on the output current, the following equations is used:

$$\text{Flow } Q = \left(\frac{Q \text{ at } 20 \text{ mA} - Q \text{ at } 4 \text{ mA}}{16 \text{ mA}} \right) * I - \left(\frac{Q \text{ at } 20 \text{ mA} - (5 * Q \text{ at } 4 \text{ mA})}{4 \text{ mA}} \right)$$

When a calibration factor is set additionally on the web interface, the following equation must be used:

Figure 23: Flow Rate vs. Output Current

$$\text{Flow } Q = \left[\left(\frac{Q \text{ at } 20 \text{ mA} - Q \text{ at } 4 \text{ mA}}{16 \text{ mA}} \right) * I - \left(\frac{Q \text{ at } 20 \text{ mA} - (5 * Q \text{ at } 4 \text{ mA})}{4 \text{ mA}} \right) \right] * \text{ set calibration factor}$$



The maximum external resistance load must not exceed 560 Ω.

8.2 Zero Flow Adjustment via the Analog Interface

Each flow channel can be zeroed over the analog interface. Generally speaking, a zero flow adjustment is carried out by increasing the current on the analog interface from 4 mA - 8 mA to 12 mA - 20 mA. Depending on whether the undo-zeroing function is set on the web interface or not, the method differs slightly.



The internal resistance load of the analog input interface is 249 Ω.

8.2.1 Zero Flow Adjustment If the Undo-Zeroing Function Is Set to OFF

In case the undo-zeroing function is not set on the System Configuration page of the web interface, the BioProTT™ FlowMCP-a can be zeroed using a simple push button.

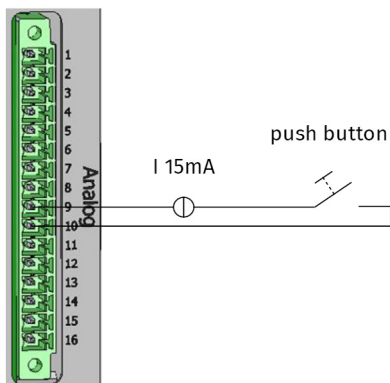
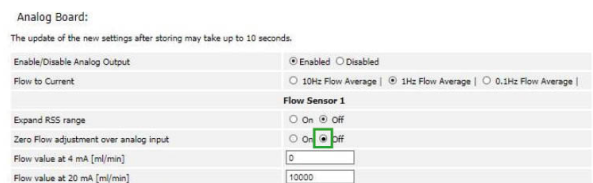

Figure 23: Zeroing using a push button

To do so, follow these steps:

1. Connect a current source to Pin 9 and 10 for flow channel 1, Pin 11 and 12 for flow channel 2.
2. Connect a push button.
3. Increase the current from 4 mA - 8 mA to 12 mA - 20 mA by pressing the button to zero the flow on the respective flow channel.

Please note:

- If the offset is too big, i.e. $\pm 3\,000$ ml/min (e.g. because the pump is still running), a zero flow adjustment is not possible.
- Once the button was pressed, the falling current will have no effect.
- You need one push button per flow channel.
- The push button must not remain pressed but go back to its original position.

8.2.2 Zero Flow Adjustment If the Undo-Zero Function Is Set to ON

In case the undo-zeroing function is set on the web interface, the BioProTT™ FlowMCP-a can be zeroed using a toggle switch.

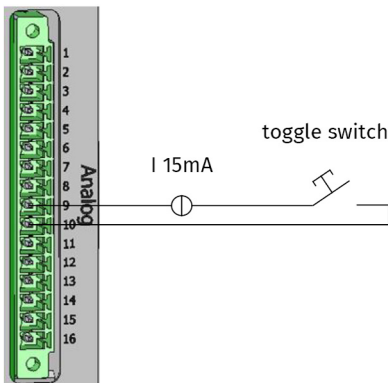
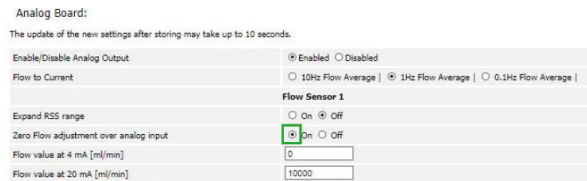

Figure 24: Zeroing using a toggle switch

To do so, follow these steps:

1. Connect a current source to Pin 9 and 10 for flow channel 1 and to Pin 11 and 12 for flow channel 2.
2. Connect a toggle switch.
3. Increase the current from 4mA - 8 mA to 12 mA - 20 mA to zero the flow on the respective flow channel.

Please note:

- If the offset is too big, i.e. $\pm 3\,000$ ml/min (e.g. because the pump is still running), a zero flow adjustment is not possible.
- The current must stay within the range of 12 mA - 20 mA. Once the current falls below 12 mA, the zero flow adjustment is reset to the original drift.
- You need one toggle switch per flow channel.
- The push button must not remain pressed but go back to its original position.

To carry out another zero flow adjustment,

- first decrease the current to 4 mA - 8 mA
- then increase it to 12 mA - 20 mA.

9 Cleaning the BioProTT™ FlowMCP

The BioProTT™ FlowMCP can be cleaned with a damp cloth. The cleaning needs to be performed when the device is off. To dampen the cloth, use water only.



Make sure that no particles or water enter the device. The accessory connecting plugs and power connection must only be plugged in when dry.

10 Troubleshooting, Support and Service

10.1 Troubleshooting

If any issues occur with the BioProTT™ FlowMCP, try the following suggestions. If the problem persists, please contact your local distributor or em-tec GmbH directly.

The most common reason for an error/warning occurring is that the system has not been properly assembled. Ensure that the sensor and power supply cables have been properly attached and that there are no electromagnetic interferences influencing the system.

Notes:

- If multiple errors/warnings are active simultaneously, only the error/warning that occurred first is reported.
- If a warning or error activates repeatedly, discontinue use and return the device for servicing.
- If a warning or error occurs that is not listed in the table below, please contact your local distributor or em-tec GmbH directly.

10.1.1 Errors and Warnings Originating from the Flow Measurement Board

These errors/warnings are sent via the Modbus TCP register and additionally displayed on the web interface of the device. When the analog interface is present (BioProTT™ FlowMCP-a) and an error/warning is activated, the current on the corresponding flow channel (RSS and flow current interface) is set to 0.5 mA ±1 %.

Problem/Possible Cause	*Auto-Reset Function	Action
Error Codes: 101_{hex} (257_{dec}); 102_{hex} (258_{dec}); 10A_{hex} (266_{dec}) –start-up self-test on flow measurement board failed during memory checks		
Internal failure on flow measurement board (ROM-, RAM failure) during start-up was detected.	✓	<p>If auto-reset function is not set:</p> <ol style="list-style-type: none"> 1. Power off the device (disconnect the power supply) or perform a reset of the flow channel. 2. Power on the device again (reconnect the power supply). <p>→ If the error is no longer present, the device can be used like normal.</p> <p>→ If the problem persists, return the device for servicing.</p> <p>If the auto-reset function is set:</p> <p>The BioProTT™ FlowMCP resets the board to clear the error.</p> <p>→ If the error is no longer present, then the device can be used like normal.</p> <p>→ If the problem persists, return the device for servicing.</p>

Problem/Possible Cause	*Auto-Reset Function	Action
Error Codes: 103_{hex} (259_{dec}); 104_{hex} (260_{dec}); 105_{hex} (261_{dec}); 106_{hex} (262_{dec}); 107_{hex} (263_{dec}); 10B_{hex} (267_{dec}) —start-up self-test on flow measurement board failed during flow measurement board voltage checks		
Internal voltage failure was detected on the flow measurement board during start-up.	✓	Ensure the power supply for the BioProTT™ FlowMCP is within the specified operating range. If auto-reset function is not set: <ol style="list-style-type: none"> 1. Power off the device (disconnect the power supply) or perform a reset of the flow channel. 2. Power on the device again (reconnect the power supply). → If the error is no longer present, the device can be used like normal. → If the problem persists, return the device for servicing. If the auto-reset function is set: The BioProTT™ FlowMCP resets the board to clear the error. → If the error is no longer present, then the device can be used like normal. → If the problem persists, return the device for servicing.
Problem/Possible Cause	*Auto-Reset Function	Action
Error Codes: 108_{hex} (264_{dec}); 109_{hex} (265_{dec}) —start-up self-test on flow measurement board failed during flow measurement board temperature checks		
The temperature inside the device is too high.	✓	Ensure the ambient temperature is within the specified operating range. If the temperature is too high, cool the device down. If auto-reset function is not set: <ol style="list-style-type: none"> 1. Power off the device (disconnect the power supply) or perform a reset of the flow channel. 2. Power on the device again (reconnect the power supply). → If the error is no longer present, the device can be used like normal. → If the problem persists, return the device for servicing. If the auto-reset function is set: The BioProTT™ FlowMCP resets the board to clear the error. → If the error is no longer present, then the device can be used like normal. → If the problem persists, return the device for servicing.

Problem/Possible Cause	*Auto-Reset Function	Action
Error Codes: 202_{hex} (514_{dec}) –run-time self-test on flow measurement board failed during memory check		
Internal failure (ROM failure) during run-time.	✓	<p>If auto-reset function is not set:</p> <ol style="list-style-type: none"> 1. Power off the device (disconnect the power supply) or perform a reset of the flow channel. 2. Power on the device again (reconnect the power supply). <p>→ If the error is no longer present, the device can be used like normal.</p> <p>→ If the problem persists, return the device for servicing.</p> <p>If the auto-reset function is set:</p> <p>The BioProTT™ FlowMCP resets the board to clear the error.</p> <p>→ If the error is no longer present, then the device can be used like normal.</p> <p>→ If the problem persists, return the device for servicing.</p>
Error Codes: 203_{hex} (515_{dec}); 204_{hex} (516_{dec}); 205_{hex} (517_{dec}); 206_{hex} (518_{dec}); 207_{hex} (519_{dec}); 20E_{hex} (526_{dec}) –run-time self-test on flow measurement board failed during flow measurement board voltage checks		
Internal voltage failure was detected on the flow measurement board during run-time mode.	✗	<p>Ensure the power supply for the BioProTT™ FlowMCP is within the specified operating range.</p> <ol style="list-style-type: none"> 1. Power off the device (disconnect the power supply) or perform a reset of the flow channel. 2. Power on the device again (reconnect the power supply). <p>→ If the error is no longer present, the device can be used like normal.</p> <p>→ If the problem persists, return the device for servicing.</p>
Error Codes: 208_{hex} (520_{dec}) –run-time self-test on flow measurement board failed during flow measurement board temperature checks		
The temperature inside the device is too high.	✗	<p>Ensure the ambient temperature is within the specified operating range. If the temperature is too high, cool the device down.</p> <ol style="list-style-type: none"> 1. Power off the device (disconnect the power supply) or perform a reset of the flow channel. 2. Power on the device again (reconnect the power supply). <p>→ If the error is no longer present, the device can be used like normal.</p> <p>→ If the problem persists, return the device for servicing.</p>

Problem/Possible Cause	*Auto-Reset Function	Action
Error Codes: 209_{hex} (521_{dec}); 20A_{hex} (522_{dec}); 20B_{hex} (523_{dec}) —run-time self-test on flow measurement board failed during flow measurement board temperature, sensor, EEPROM, or RAM check		
A failure on the flow measurement board during run-time mode of the temperature sensor, EEPROM, or RAM was detected.	✓	<p>If auto-reset function is not set:</p> <ol style="list-style-type: none"> 1. Power off the device (disconnect the power supply) or perform a reset of the flow channel. 2. Power on the device again (reconnect the power supply). <p>→ If the error is no longer present, the device can be used like normal.</p> <p>→ If the problem persists, return the device for servicing.</p> <p>If the auto-reset function is set:</p> <p>The BioProTT™ FlowMCP resets the board to clear the error.</p> <p>→ If the error is no longer present, then the device can be used like normal.</p> <p>→ If the problem persists, return the device for servicing.</p>
Error Codes: 20C_{hex} (524_{dec}); 20D_{hex} (525_{dec}) —run-time self-test on flow measurement board failed during check of the sensor calibration data		
The CRC of the internally stored sensor calibration data on the flow measurement board is not the same as the CRC value read from sensor calibration data.	✓	<p>Ensure the sensor is connected correctly to the BioProTT™ FlowMCP.</p> <p>If auto-reset function is not set:</p> <ol style="list-style-type: none"> 1. Power off the device (disconnect the power supply) or perform a reset of the flow channel. 2. Power on the device again (reconnect the power supply). <p>→ If the error is no longer present, the device can be used like normal.</p> <p>→ If the problem persists, return the device for servicing.</p> <p>If the auto-reset function is set:</p> <p>The BioProTT™ FlowMCP resets the board to clear the error.</p> <p>→ If the error is no longer present, then the device can be used like normal.</p> <p>→ If the problem persists, return the device for servicing.</p>
Error Codes: 301_{hex} (769_{dec}) —wrong flow sensor type detected on the flow measurement board		
The connected sensor is the wrong sensor type and is not valid for the BioProTT™ FlowMCP.	✗	<ol style="list-style-type: none"> 1. Check if the correct sensor is connected and not damaged. 2. If the correct sensor is connected, disconnect the sensor. 3. Reconnect the sensor again. <p>→ If the error is no longer present, the device can be used like normal.</p> <p>→ If the problem persists, return the device for servicing.</p>

Problem/Possible Cause	*Auto-Reset Function	Action
Error Codes: 302_{hex} (770_{dec}); 303_{hex} (771_{dec}) –sensor EEPROM read error		
Sensor EEPROM with sensor calibration values could not be read correctly after the sensor was connected or after the BioProTT™ FlowMCP was started.	x	<ol style="list-style-type: none"> 1. Check if the sensor is connected properly to the BioProTT™ FlowMCP and ensure that the sensor is not damaged. 2. Check if there are not electromagnetic disturbances on the sensor cables (e.g. disturbances from a pump). 3. Disconnect the sensor. 4. Reconnect the sensor again. <p>→ If the error is no longer present, the device can be used like normal.</p> <p>→ If the problem persists, return the device for servicing.</p>
Error Codes: 401_{hex} (1025_{dec}) –signal processing FPGA test cycle failed		
During an internal signal processing test of the FPGA component on the flow measurement board, a failure was detected. Electromagnetic disturbances could lead to this failure situation.	✓	<p>If auto-reset function is not set:</p> <ol style="list-style-type: none"> 1. Check if there are any electromagnetic disturbances that might influence the system. Also check the line grounding. 2. Power off the device (disconnect the power supply) or perform a reset of the flow channel. 3. Power on the device again (reconnect the power supply). <p>→ If the error is no longer present, the device can be used like normal.</p> <p>→ If the problem persists, return the device for servicing.</p> <p>If the auto-reset function is set:</p> <p>The BioProTT™ FlowMCP resets the board to clear the error.</p> <p>→ If the error is no longer present, then the device can be used like normal.</p> <p>→ If the problem persists, return the device for servicing.</p>
Error Codes: 402_{hex} (1026_{dec}) –sensor wire break of measurement signal lines detected		
The sensor cable (including the sensor extension cable) is damaged (e.g. wire break) or the tube is not completely filled with liquid.	x	<ol style="list-style-type: none"> 1. Check if the sensor is connected properly to the BioProTT™ FlowMCP and ensure that the sensor cable and/or the sensor extension cable are not damaged. 2. Check if the tube is completely filled with liquid. 3. Power off the device (disconnect the power supply). 4. Power on the device again (reconnect the power supply). <p>→ If the error is no longer present, the device can be used like normal.</p> <p>→ If the problem persists, return the device for servicing.</p>

EN

Problem/Possible Cause	*Auto-Reset Function	Action
Error Codes: 605_{hex} (1541_{dec}); 606_{hex} (1542_{dec}); 607_{hex} (1543_{dec}); 608_{hex} (1544_{dec}); 609_{hex} (1545_{dec}); 60A_{hex} (1546_{dec}); 60B_{hex} (1547_{dec}) —an internal CAN communication failure was detected on the flow measurement board		
On the internal CAN data communication of the flow measurement board(s) to the BioProTT™ FlowMCP main PCB, a failure was detected. The internal data communication has failed. Electromagnetic disturbances could lead to this failure situation.	✓	<p>If auto-reset function is not set:</p> <ol style="list-style-type: none"> 1. Check if there are any electromagnetic disturbances that might influence the system. Also check the line grounding. 2. Power off the device (disconnect the power supply) or perform a reset of the flow channel. 3. Power on the device again (reconnect the power supply). <p>→ If the error is no longer present, the device can be used like normal.</p> <p>→ If the problem persists, return the device for servicing.</p> <p>If the auto-reset function is set:</p> <p>The BioProTT™ FlowMCP resets the board to clear the error.</p> <p>→ If the error is no longer present, then the device can be used like normal.</p> <p>→ If the problem persists, return the device for servicing.</p>
Error Codes: 701_{hex} (1793_{dec}); 702_{hex} (1794_{dec}) —FPGA test on the flow measurement board failed during start-up		
During the start-up or after a flow channel reset, a failure on the flow measurement board FPGA was detected.	✓	<p>If auto-reset function is not set:</p> <ol style="list-style-type: none"> 1. Power off the device (disconnect the power supply) or perform a reset of the flow channel. 2. Power on the device again (reconnect the power supply). <p>→ If the error is no longer present, the device can be used like normal.</p> <p>→ If the problem persists, return the device for servicing.</p> <p>If the auto-reset function is set:</p> <p>The BioProTT™ FlowMCP resets the board to clear the error.</p> <p>→ If the error is no longer present, then the device can be used like normal.</p> <p>→ If the problem persists, return the device for servicing.</p>

Problem/Possible Cause	*Auto-Reset Function	Action
Error Codes: 703_{hex} (1795_{dec}); 704_{hex} (1796_{dec}); 705_{hex} (1797_{dec}); 801_{hex} (2049_{dec}); B02_{hex} (2818_{dec}); B03_{hex} (2819_{dec}); B04_{hex} (2820_{dec}); B08_{hex} (2821_{dec}) –internal failure on the flow measurement board was detected		
An internal failure was detected on the flow measurement board during the flow measurement.	✓	<p>If auto-reset function is not set:</p> <ol style="list-style-type: none"> 1. Power off the device (disconnect the power supply) or perform a reset of the flow channel. 2. Power on the device again (reconnect the power supply). <p>→ If the error is no longer present, the device can be used like normal.</p> <p>→ If the problem persists, return the device for servicing.</p> <p>If the auto-reset function is set:</p> <p>The BioProTT™ FlowMCP resets the board to clear the error.</p> <p>→ If the error is no longer present, then the device can be used like normal.</p> <p>→ If the problem persists, return the device for servicing.</p>
Error Codes: C01_{hex} (3073_{dec}); C02_{hex} (3074_{dec}) –failure on a software task of the flow measurement board was detected		
Internal software task failure on the flow measurement board.	✓	<p>If auto-reset function is not set:</p> <ol style="list-style-type: none"> 1. Power off the device (disconnect the power supply) or perform a reset of the flow channel. 2. Power on the device again (reconnect the power supply). <p>→ If the error is no longer present, the device can be used like normal.</p> <p>→ If the problem persists, return the device for servicing.</p> <p>If the auto-reset function is set:</p> <p>The BioProTT™ FlowMCP resets the board to clear the error.</p> <p>→ If the error is no longer present, then the device can be used like normal.</p> <p>→ If the problem persists, return the device for servicing.</p>
Error Codes: D01_{hex} (3329_{dec}) –internal database CRC or flow measurement board EEPROM communication failed		
The data transfer to or from the flow measurement board EEPROM (and therefore to the internal database) failed.	✗	<ol style="list-style-type: none"> 1. Power off the device (disconnect the power supply) or perform a reset of the flow channel. 2. Power on the device again (reconnect the power supply). <p>→ If the error is no longer present, the device can be used like normal.</p> <p>→ If the problem persists, return the device for servicing.</p>

EN

<p>*)</p> <ul style="list-style-type: none"> • It is possible to set the auto-reset function for some error types (indicated by a "✓" in the table above; the "x" indicates that it is not possible to set the auto-reset function) on the web interface set-up page. • By setting this function, these errors/warnings are automatically reset by the BioProTT™ FlowMCP without any additional actions from the operator. • This means that when the auto-reset function is set, the BioProTT™ FlowMCP automatically resets the flow measurement board when detecting an error/a warning. • Should the error/warning still be present after a reset of the flow measurement took place, the error/warning code will be displayed via the Modbus TCP interface as well as on the analog interface if available. • Should the error/warning no longer be present after a reset, the device can be used like normal.
 <p>During an automatic reset of the board, the measured flow value and/or the RSS value of the respective flow channels may go down to zero for a few seconds.</p>

Table 19 Error and Warning originating from the flow measurement board

10.1.2 Global Errors and Warnings Originating from the BioProTT™ FlowMeasurement Board

The most common reason for an error occurring is that the system has not been properly assembled. Ensure that the sensor and power supply cables have been properly attached and that there are no electromagnetic interferences influencing the system.

This global error is sent via the Modbus TCP register index 97 (see chapter 7.1.1) and additionally displayed on the web interface of the device. When the analog interface is present (BioProTT™ FlowMCP-a) and a global error is activated, the current on the corresponding flow channel (RSS and flow current interface) is set to 0.5 mA ±1 %.

Problem/Possible Cause	*Auto-Reset Function	Action
<p>Error Codes: 101_{hex} (257_{dec}); 102_{hex} (258_{dec}); 104_{hex} (260_{dec}); 108_{hex} (264_{dec}) —a flow measurement board was unintentionally reset</p> <p>Error Code 101_{hex} signals an unintentional reset of flow measurement board 1; error code 102_{hex} signals an unintentional reset of flow measurement board 2; error code 104_{hex} signals an unintentional reset of flow measurement board 3, and error code 108_{hex} signals an unintentional reset of flow measurement board 4</p>		
<p>One of the flow measurement boards was unintentionally reset, e.g. by an electromagnetic disturbance on the BioProTT™ FlowMCP or on the sensor.</p>	x	<p>For this error, there is no action required. The error can be reset via the web interface main page by clicking the "Reset Global Error" button. If the error occurs frequently, return the device for servicing.</p>
<p>Error Codes: 201_{hex} (513_{dec}); 202_{hex} (514_{dec}); 204_{hex} (516_{dec}); 208_{hex} (520_{dec}) —inadvertent missing or lost communication from the flow measurement board to the main board of the BioProTT™ FlowMCP</p> <p>Error Code 201_{hex} failure of flow measurement board 1; error code 202_{hex} failure of flow measurement board 2, error code 204_{hex} failure of flow measurement board 3, and error code 208_{hex} failure of flow measurement board 4</p>		
<p>The communication of one or more flow measurement boards to the main board of the BioProTT™ FlowMCP was lost; e.g. board is defect or permanently reset.</p>	x	<ol style="list-style-type: none"> 1. Power off the device (disconnect the power supply) or perform a reset of the flow channel. 2. Power on the device again (reconnect the power supply). <p>→ If the error is no longer present, the device can be used like normal.</p> <p>→ If the problem persists, return the device for servicing.</p>

Problem/Possible Cause	*Auto-Reset Function	Action
<p>Error Codes: 301_{hex} (769_{dec}); 302_{hex} (770_{dec}); 304_{hex} (772_{dec}); 308_{hex} (776_{dec}) –communication failure between the flow measurement board and the main board of the BioProTT™ FlowMCP Error Code 301_{hex} failure of flow measurement board 1; error code 302_{hex} failure of flow measurement board 2, error code 304_{hex} failure of flow measurement board 3, and error code 308_{hex} failure of flow measurement board 4</p>		
<p>A failure was detected on the internal device communication between the flow measurement board and the main board of the BioProTT™ FlowMCP.</p>	<p>✓</p>	<p>If auto-reset function is not set:</p> <ol style="list-style-type: none"> 1. Power off the device (disconnect the power supply) or perform a reset of the flow channel. 2. Power on the device again (reconnect the power supply). <p>→ If the error is no longer present, the device can be used like normal.</p> <p>→ If the problem persists, return the device for servicing.</p> <p>If the auto-reset function is set:</p> <p>The BioProTT™ FlowMCP resets the board to clear the error.</p> <p>→ If the error is no longer present, then the device can be used like normal.</p> <p>→ If the problem persists, return the device for servicing.</p>
<p>*)</p> <ul style="list-style-type: none"> • It is possible to set the auto-reset function for some error types (indicated by a "✓" in the table above) on the web interface set-up page. • By setting this function, these errors/warnings are automatically reset by the BioProTT™ FlowMCP without any additional actions from the operator. • This means that when the auto-reset function is set, the BioProTT™ FlowMCP automatically resets the flow measurement board when detecting an error/a warning. • Should the error/warning still be present after a reset of the flow measurement took place, the error/warning code will be displayed via the Modbus TCP interface as well as on the analog interface if available. • Should the error/warning no longer be present after a reset, the device can be used like normal. 		
<div style="display: flex; align-items: center;">  <p>During an automatic reset of the board, the measured flow value and/or the RSS value of the respective flow channels may go down to zero for a few seconds.</p> </div>		

Table 20: Global Errors and Warnings

EN

10.1.3 Analog Errors and Warnings Originating from the BioProTT™ FlowMCP-a

The most common reason for an error occurring is that the system has not been properly assembled. Ensure that the sensor and power supply cables have been properly attached and that there are no electromagnetic interferences influencing the system.

These errors are sent via the analog interface and additionally displayed on the web interface of the device. When an error is activated, the current on the corresponding flow channel (RSS and flow current interface) is set to 0.5 mA ±1 %.

Problem/Possible Cause	*Auto-Reset Function	Action
Error Codes: 101_{hex} (257_{dec}) — start-up self-test on flow measurement board failed during memory checks		
Internal failure on flow measurement board (RAM-failure) during start-up was detected.	✓	<p>If auto-reset function is not set:</p> <ol style="list-style-type: none"> 1. Power off the device (disconnect the power supply) or perform a reset of the flow channel. 2. Power on the device again (reconnect the power supply). <p>→ If the error is no longer present, the device can be used like normal.</p> <p>→ If the problem persists, return the device for servicing.</p> <p>If the auto-reset function is set:</p> <p>The BioProTT™ FlowMCP resets the board to clear the error.</p> <p>→ If the error is no longer present, then the device can be used like normal.</p> <p>→ If the problem persists, return the device for servicing.</p>
Error Codes: 102_{hex} (258_{dec}); 103_{hex} (259_{dec}); 104_{hex} (260_{dec}) — start-up self-test on flow measurement board failed during board voltage checks		
Internal voltage failure was detected on the flow measurement board during start-up.	✓	<p>Ensure the power supply for the BioProTT™ FlowMCP is within the specified operating range.</p> <p>If auto-reset function is not set:</p> <ol style="list-style-type: none"> 1. Power off the device (disconnect the power supply) or perform a reset of the flow channel. 2. Power on the device again (reconnect the power supply). <p>→ If the error is no longer present, the device can be used like normal.</p> <p>→ If the problem persists, return the device for servicing.</p> <p>If the auto-reset function is set:</p> <p>The BioProTT™ FlowMCP resets the board to clear the error.</p> <p>→ If the error is no longer present, then the device can be used like normal.</p> <p>→ If the problem persists, return the device for servicing.</p>

Problem/Possible Cause	*Auto-Reset Function	Action
Error Codes: 105_{hex} (261_{dec}); 106_{hex} (262_{dec}) — start-up temperature check failed		
<p>The temperature inside the device is too high.</p>	✓	<p>Ensure the ambient temperature is within the specified operating range. If the temperature is too high, cool the device down.</p> <p>If auto-reset function is not set:</p> <ol style="list-style-type: none"> 1. Power off the device (disconnect the power supply) or perform a reset of the flow channel. 2. Power on the device again (reconnect the power supply). <p>→ If the error is no longer present, the device can be used like normal.</p> <p>→ If the problem persists, return the device for servicing.</p> <p>If the auto-reset function is set:</p> <p>The BioProTT™ FlowMCP resets the board to clear the error.</p> <p>→ If the error is no longer present, then the device can be used like normal.</p> <p>→ If the problem persists, return the device for servicing.</p>
Error Codes: 201_{hex} (513_{dec}); 202_{hex} (514_{dec}) — run-time self-test on flow measurement board failed during memory check		
<p>Internal failure (ROM failure) during run-time.</p>	✓	<p>If auto-reset function is not set:</p> <ol style="list-style-type: none"> 1. Power off the device (disconnect the power supply) or perform a reset of the flow channel. 2. Power on the device again (reconnect the power supply). <p>→ If the error is no longer present, the device can be used like normal.</p> <p>→ If the problem persists, return the device for servicing.</p> <p>If the auto-reset function is set:</p> <p>The BioProTT™ FlowMCP resets the board to clear the error.</p> <p>→ If the error is no longer present, then the device can be used like normal.</p> <p>→ If the problem persists, return the device for servicing.</p>

Problem/Possible Cause	*Auto-Reset Function	Action
Error Codes: 203_{hex} (515_{dec}); 204_{hex} (516_{dec}); 205_{hex} (517_{dec}) – run-time self-test on flow measurement board failed during flow measurement board voltage checks		
Internal voltage failure was detected on the flow measurement board during run-time mode.	×	Ensure the power supply for the BioProTT™ FlowMCP is within the specified operating range. <ol style="list-style-type: none"> 1. Power off the device (disconnect the power supply) or perform a reset of the flow channel. 2. Power on the device again (reconnect the power supply). → If the error is no longer present, the device can be used like normal. → If the problem persists, return the device for servicing.
Error Codes: 207_{hex} (519_{dec}); 208_{hex} (520_{dec}); 209_{hex} (521_{dec}) – run-time self-test on flow measurement board failed during flow measurement board temperature check		
A failure on the flow measurement board during run-time mode of the temperature was detected.	×	Ensure the ambient temperature is within the specified operating range. If the temperature is too high, cool the device down. <ol style="list-style-type: none"> 1. Power off the device (disconnect the power supply) or perform a reset of the flow channel. 2. Power on the device again (reconnect the power supply). → If the error is no longer present, the device can be used like normal. → If the problem persists, return the device for servicing.
Error Codes: 20A_{hex} (522_{dec}); 20B_{hex} (523_{dec}) – run-time self-test on flow measurement board failed during, EEPROM or RAM check		
A failure on the flow measurement board during run-time mode of the EEPROM or RAM was detected.	✓	If auto-reset function is not set: <ol style="list-style-type: none"> 1. Power off the device (disconnect the power supply) or perform a reset of the flow channel. 2. Power on the device again (reconnect the power supply). → If the error is no longer present, the device can be used like normal. → If the problem persists, return the device for servicing. If the auto-reset function is set: The BioProTT™ FlowMCP resets the board to clear the error. → If the error is no longer present, then the device can be used like normal. → If the problem persists, return the device for servicing.

Problem/Possible Cause	*Auto-Reset Function	Action
Error Codes: 20C_{hex} (524_{dec}); 20D_{hex} (525_{dec}); 301_{hex} (769_{dec}); 302_{hex} (770_{dec}) – run-time self-test on flow measurement board communication to analog board failed		
A communication ERROR of the flow measurement board to the analog board PCB was detected.	✓	<p>If auto-reset function is not set:</p> <ol style="list-style-type: none"> 1. Power off the device (disconnect the power supply) or perform a reset of the flow channel. 2. Power on the device again (reconnect the power supply). <p>→ If the error is no longer present, the device can be used like normal.</p> <p>→ If the problem persists, return the device for servicing.</p> <p>If the auto-reset function is set:</p> <p>The BioProTT™ FlowMCP resets the board to clear the error.</p> <p>→ If the error is no longer present, then the device can be used like normal.</p> <p>→ If the problem persists, return the device for servicing.</p>
Error Codes: 402_{hex} (1026_{dec}) – over temperature of analog interface		
Temperature of the analog interface is too high.	✗	<p>Ensure that the resistance load on the analog interface is within the specified range and max. 560 Ω.</p> <ol style="list-style-type: none"> 1. Power off the device (disconnect the power supply) or perform a reset of the flow channel. 2. Power on the device again (reconnect the power supply). <p>→ If the error is no longer present, the device can be used like normal.</p> <p>→ If the problem persists, return the device for servicing.</p>
Error Codes: 501_{hex} (1281_{dec}) – internal failure on analog board		
An failure on the internal communication of the analog board was detected.	✓	<p>If auto-reset function is not set:</p> <ol style="list-style-type: none"> 1. Power off the device (disconnect the power supply) or perform a reset of the flow channel. 2. Power on the device again (reconnect the power supply). <p>→ If the error is no longer present, the device can be used like normal.</p> <p>→ If the problem persists, return the device for servicing.</p> <p>If the auto-reset function is set:</p> <p>The BioProTT™ FlowMCP resets the board to clear the error.</p> <p>→ If the error is no longer present, then the device can be used like normal.</p> <p>→ If the problem persists, return the device for servicing.</p>

Problem/Possible Cause	*Auto-Reset Function	Action
Error Codes: 502_{hex} (1282_{dec}) –internal failure on analog board		
An failure on the internal communication of the analog board was detected.	×	<ol style="list-style-type: none"> 1. Power off the device (disconnect the power supply) or perform a reset of the flow channel. 2. Power on the device again (reconnect the power supply). <p>→ If the error is no longer present, the device can be used like normal.</p> <p>→ If the problem persists, return the device for servicing.</p>
Error Codes: D01_{hex} (3329_{dec}); D02_{hex} (3330_{dec}); D03_{hex} (3331_{dec}) –internal database CRC or board EEPROM communication failed		
The data transfer to or from the analog board EEPROM (and therefore to the internal database) failed.	×	<ol style="list-style-type: none"> 1. Power off the device (disconnect the power supply) or perform a reset of the flow channel. 2. Power on the device again (reconnect the power supply). <p>→ If the error is no longer present, the device can be used like normal.</p> <p>→ If the problem persists, return the device for servicing.</p>
Error Codes: E01_{hex} (3585_{dec}); E02_{hex} (3586_{dec}) – failure on a software task of the analog board was detected		
Internal software task failure on the analog board.	×	<ol style="list-style-type: none"> 1. Power off the device (disconnect the power supply) or perform a reset of the flow channel. 2. Power on the device again (reconnect the power supply). <p>→ If the error is no longer present, the device can be used like normal.</p> <p>→ If the problem persists, return the device for servicing.</p>
<p>*)</p> <ul style="list-style-type: none"> • It is possible to set the auto-reset function for some error types (indicated by a "✓" in the table above) on the web interface set-up page. • By setting this function, these errors/warnings are automatically reset by the BioProT™ FlowMCP without any additional actions from the operator. • This means that when the auto-reset function is set, the BioProTT™ FlowMCP automatically resets the flow measurement board when detecting an error/a warning. • Should the error/warning still be present after a reset of the flow measurement took place, the error/warning code will be displayed via the Modbus TCP interface as well as on the analog interface if available. • Should the error/warning no longer be present after a reset, the device can be used like normal. 		
<div style="display: flex; align-items: center;">  <p>During an automatic reset of the board, the measured flow value and/or the RSS value of the respective flow channels may go down to zero for a few seconds.</p> </div>		

Table 21: Analog Errors and Warnings

10.1.4 Other Troubleshooting

The most common reason for an error/warning occurring is that the system has not been properly assembled. Ensure that the sensor and power supply cables have been properly attached and that there are no electromagnetic interferences influencing the system.

Problem/Possible cause	Action
Power LED off	
Power not connected; voltage/current of power supply too low	Check if the power supply is connected and delivers +24 V ± 10 %.
Defect of internal fuse of device	Return the device for servicing.
Polarity reversed	Please check the correct power supply and PIN assignment (see Table 6.2 or 7.2)
Device LED blinking	
Device failure is present	Check via web server or Modbus interface if there is an error or warning present and refer to error warning and troubleshooting in chapter 10.1.1..
Device configuration lost	Return the device for servicing.
Sensor LED blinking	
Not all sensor connected to the device	Check if all sensors (e.g. 2 on a BioProTT™ FlowMCP 2) are connected properly and working.
Extension cable is defect	Check the sensor extension cable for defects
Sensor failure is present	Check via web server or Modbus interface if there is an error or warning present and refer to error warning and troubleshooting in chapter 10.1.1.
Ethernet Link LED does not light up	
No ethernet connection is available	<ol style="list-style-type: none"> 1. Check if the BioProTT™ FlowMCP is connected properly to the Modbus TCP interface of the PLC. 2. Check if the IP address of the BioProTT™ FlowMCP is correct. <p>If the problem persist, return the device for servicing.</p>
Ethernet Activity LED does not light up	
No ethernet communication available	<ol style="list-style-type: none"> 1. Check if the BioProTT™ FlowMCP is connected properly to the Modbus TCP interface of the PLC 2. Check if the IP address of the MCP device is correct and is in the same network as the PLC. 3. Disconnect the Ethernet interface. 4. Reconnect the Ethernet interface again. <p>If the problem persists, return the device for servicing.</p>

Problem/Possible cause	Action
Flow reading not in the specified range	
A wrong calibration factor is set of a flow channel	Check on the device web server (refer to Figure 17 or 18) if the calibration factor is set correctly.
Calibration table selection or zero setting lost after power cycle or flow channel reset	
Keep sensor settings function is not set.	Check on the device web server (refer to Figure 17 or 18) if the "keep sensor settings" are set correctly.
Sensor is sometimes not recognized or flow channel resets sometimes	
Electromagnetic disturbances affect the sensor connection or flow measurement boards	<ol style="list-style-type: none"> 1. Check if e.g. cables with high noise emission (e.g. cables from a motor driver such as a frequency converter to a motor) are separated from the sensor extension cables. 2. Ensure that the BioProTT™ FlowMCP, the extension cables and the sensors are located far away from electromagnetic noise sources. <p>If the problem persists, return the device for servicing.</p>
Zero flow adjustment is not possible	
Flow offset is bigger than 3,000 ml/min.	<ol style="list-style-type: none"> 1. Check if the pump is turned off and that there is no flow within the system. 2. Check if the sensor is damaged in any way. <p>If the flow offset remains despite the pump being stopped, please contact em-tec GmbH.</p>
Analog output value not within the expected range	
Current analog output values e.g. at flow channel 1 are <1 mA	<ol style="list-style-type: none"> 1. Check if any error is present on the device. 2. Check if the analog interface is enabled. <p>If the problem persists, please contact our service department.</p>
Current analog output value e.g. at flow channel 1 is at 0 mA	<ol style="list-style-type: none"> 1. Check if the analog interface is connected correctly. 2. Check if the cable on the analog interface is damaged. <p>If the problem persists, please contact our service department.</p>
It is not possible to undo the zeroing over the analog input.	<ol style="list-style-type: none"> 1. Check if the "allow zero flow adjustment" function is set to "on" for the analog interface. 2. Check if the connection to the analog interface is correct. <p>If the problem persists, please contact our service department.</p>

Table 22: Other troubleshooting

10.2 Status Information Troubleshooting

The status information of the flow channels contains information regarding the channels' conditions such as additional information about the connected sensor. The status is displayed on the web interface and on the Modbus TCP interface as hexadecimal value in form of a 16 bit word (2 byte).



When the status information is used for the integration of the BioProTT™ FlowMCP into an industrial system, please contact em-tec GmbH for more detailed information in regard to the integration.

The status information looks as follows:

Bit No.	When bit is "0"	Status as hexadecimal value	When bit is "1"	Status as hexadecimal value
0	Measurement is running*	0 _{hex}	Measurement was stopped*	1 _{hex}
1	Sensor was entirely loaded**		Sensor not (yet) entirely loaded**	2 _{hex}
2	A sensor is connected*		No sensor connected**	4 _{hex}
3	Temperature is ok Flow measurement board temperature <65°C		Temperature warning Flow measurement board temperature >70°C	8 _{hex}
4	The coupling (RSS) of the sensor on channel 1 is ok		The coupling (RSS) of the sensor on channel 1 is below 50 %	10 _{hex}
5	The coupling (RSS) of the sensor on channel 1 is ok		No coupling (RSS) on channel 1 (below 1 %)	20 _{hex}
6	The coupling (RSS) of the sensor on channel 2 is ok.		The coupling (RSS) of the sensor on channel 2 is below 50 %	40 _{hex}
7	The coupling (RSS) of the sensor on channel 2 is ok.		No coupling (RSS) on channel 2 (below 1 %)	80 _{hex}
8	Offset correction on sensor connected to channel 1 is possible		Offset correction on sensor connected to channel 1 is not possible (flow too high/depends on connected sensor)	100 _{hex}
9	Offset correction on sensor connected to channel 2 is possible		Offset correction on sensor connected to channel 2 is not possible (flow too high/depends on connected sensor)	200 _{hex}
10	Sensor was not zeroed,yet		Sensor was zeroed or sensor is known and was zeroed before*	400 _{hex}
11	-		-	-
12	-		Bit 0 of currently used calibration table**	1000 _{hex}
13	-		Bit 1 of currently used calibration table**	2000 _{hex}
14	-		Bit 2 of currently used calibration table**	4000 _{hex}
15	Power-On flag on the flow measurement was reset by the BioProTT™ FlowMCP		Power-On flag on the flow measurement board was not yet reset by the BioProTT™ FlowMCP***	8000 _{hex}

- *) The status information signals that the measurement on the flow measurement board is running. The status cannot be influenced by the BioProTT™ FlowMCP and will be automatically reset to "0" when a sensor is connected to the flow channel.
- ***) This status information is also present in the Modbus TCP registers.
- ****) This flag is used internally in the BioProTT™ FlowMCP to detect inadvertent resets of the flow measurement board.

Table 23: Status Information Troubleshooting

Possible status information could look like the following:

8007 _{hex} (1000 0000 0000 0111 _{bin})		
Bit 0 = 1	Measurement was stopped	No sensor is connected
Bit 1 = 1	Sensor not (yet) loaded	
Bit 2 = 1	No sensor connected	
Bit 15 = 1	Power-On flag on flow measurement board is 1*	
1400 _{hex} (0001 0100 0000 0000 _{bin})		
Bit 10 = 1	Sensor was zeroed or sensor is known and was zeroed before	Sensor is connected, coupling (RSS) >50 %, offset correction on sensor is possible, calibration table 1 of sensor is set
Bit 12 = 1	Bit 0 of currently used calibration table (table 1 selected)	
1450 _{hex} (0001 0100 0101 0000 _{bin})		
Bit 4 = 1	Coupling (RSS) of sensor on channel 1 is below 50 %	Sensor is connected, coupling (RSS) <50 %, offset correction on sensor is possible, calibration table 1 of sensor is set
Bit 6 = 1	Coupling (RSS) of sensor on channel 2 is below 50 %	
Bit 10 = 1	Sensor was zeroed or sensor is known and was zeroed before	
Bit 12 = 1	Bit 0 of currently used calibration table (table 1 selected)	

11 Electrical Safety and Electromagnetic Compatibility

The BioProTT™ FlowMCP is a state-of-the-art technology. Although the requirements of **EN/IEC 61010-1** and **EN/IEC 61326-1** were taken into consideration during the development and manufacturing, the user may be at risk if the device is used improperly.

The BioProTT™ FlowMCP was tested according to **EN/IEC 61010-1: 2010**, **EN 61326-1:2013** and **IEC 61326-1:2012**.

Electrical Installation Requirements

Please follow the general safety information when installing the BioProTT™ FlowMeasurement System. Please observe any separate relevant safety and technical information of other electrical components used.

Electromagnetic Compatibility Requirements

The customer has to ensure that the relevant emission and immunity requirements of the “target” device configuration are ensured in accordance with the required standards.

12 Environmental Protection and Disposal

The BioProTT™ FlowMCP is made of conventional materials (plastic, metal and electronic parts) that are harmless to humans and the environment providing it is used correctly according to current knowledge.

The device and its accessories must be disposed of in accordance with the applicable national provisions for electronic devices. In accordance with the requirements of EU Directive **2012/19/EU** Waste Electrical and Electronic Equipment (WEEE), our customers in the EU are entitled to return to us all waste devices – in clean and disinfected condition. The em-tec GmbH WEEE registration number is "**DE 99135207**".

Upon receipt, we repair or dispose these devices properly.

For our delivery address, see the very first page of this user manual or chapter 1.5 "Maintenance and Service".

13 Manufacturer's Declarations

For the BioProTT™ FlowMCP, as described in this user manual, applies the following:

The product marked with the CE sign fulfills the European harmonized standards of electromagnetic and electrical safety requirements for industrial devices.

The declaration of conformity and other certificates are provided at:

em-tec GmbH, Lerchenberg 20, 86923 Finning, Germany

14 Contact Information for Technical Support

Technical support is provided by:

em-tec GmbH

Lerchenberg 20
86923 Finning
Germany

t: +49 8806 9236 0
e: em-tec-service@psgdover.com
w: www.em-tec.de

15 Technical Specifications of the BioProTT™ FlowMCP (1-4 channels)

BioProTT™ FlowMCP (1-4 channels)

Operating principle	Ultrasonic Transit Time Flow Measurement (TTFM)
Device dimensions (HxWxD)	MCP1 and MCP2: 99 mm x 45 mm x 114.5 mm MCP 4: 99 mm x 90 mm x 114.5 mm
Weight	MCP 1: 200 g MCP 2: 240 g MCP 4: 320 g
Housing Material	Polyamide
DINrail mounting type	Standard TS35 DINrail according to EN 60715; 35 x 7.5 mm
Supply voltage	24 V DC ($\pm 10\%$) supplied external. max. 2000 mA
Power consumption	typically 3 W; max. 8 W/9 W for BioProTT™ FlowMCP4

Interfaces:

Interface types	1 x RJ 45
Protocol	Modbus TCP

Ambient Conditions:

Air pressure	70 kPa to 106 kPa
Operating altitude	up to 2000 m (6600 feet)
Operating temperature range	10°C to 40°C (50°F to 104°F)
Storage temperature range	-20°C to 45°C (-4°F to 113°F)
Transport temperature range	-20°C to 55°C (-4°F to 131°F)
IP Rating	IP20

Relative Air Humidity:

Operation	30 % to 75 % (non-condensing)
Storage and transportation	10 % to 96 % (non-condensing)

EMC:

The device was tested according to EN/IEC 61326-1, however, the safety of the overall system must be ensured by the customer.

16 Technical Specifications of the BioProTT™ FlowMCP-a

BioProTT™ FlowMCP-a

Operating principle	Ultrasonic Transit Time Flow Measurement (TTFM)
Device dimensions (HxWxD)	MCP1-a: 99 mm x 45 mm x 115 mm MCP 2-a: 99 mm x 68 mm x 115 mm
Weight	MCP 1-a: 200 g MCP 2-a: 300 g
Housing Material	Polyamide
DINrail mounting type	Standard TS35 DINrail according to EN 60715; 35 x 7.5 mm
Supply voltage	24 V DC (± 10 %) max. external supply. 2000 mA
Power consumption	typically 4 Watt; max. 6 Watt

Interfaces:

Analog Interface	(0) 4 mA - 20 mA
Protocol	Modbus TCP (RJ-45 connector)

Ambient Conditions:

Air pressure	70 kPa to 106 kPa
Operating altitude	up to 2000 m (6600 feet)
Operating temperature range	10°C to 40°C (50°F to 104°F)
Storage temperature range	-20°C to 45°C (-4°F to 113°F)
Transport temperature range	-20°C to 55°C (-4°F to 131°F)
IP Rating	IP20

Relative Air Humidity:

Operation	30 % to 75 % (non-condensing)
Storage and transportation	10 % to 96 % (non-condensing)

EMC:

The device was tested according to EN/IEC 61326-1, however, the safety of the overall system must be ensured by the customer.

About em-tec GmbH

em-tec has been a specialist for flow measurement systems in the medical and bioprocessing technology sector for over 30 years. The company's core competence is the non-invasive flow measurement using the ultrasonic transit-time method, that is used for applications in extracorporeal circulation systems of life-sustaining systems as well as in biopharma applications that use flexible tubes. Headquartered in Finning, Germany, em-tec is part of PSG®, a Dover company.

For more information about em-tec, please visit em-tec.de. For more information about PSG®, please visit psgdover.com.

About Dover

Dover is a diversified global manufacturer and solutions provider with annual revenue of approximately \$7 billion. We deliver innovative equipment and components, consumable supplies, aftermarket parts, software and digital solutions, and support services through five operating segments: Engineered Products, Fueling Solutions, Imaging & Identification, Pumps & Process Solutions and Refrigeration & Food Equipment. Dover combines global scale with operational agility to lead the markets we serve. Recognized for our entrepreneurial approach for over 60 years, our team of over 23,000 employees takes an ownership mindset, collaborating with customers to redefine what's possible. Headquartered in Downers Grove, Illinois, Dover trades on the New York Stock Exchange under "DOV." Additional information is available at dovercorporation.com.



