

CAD generated and maintained drawing. All printed and electronic copies outside of Griswold's engineering database are "Uncontrolled" and shall be used for reference only.

REV.	DESCRIPTION	BY	CHK.	APP.	DATE
A	RELEASED INTO PRODUCTION SEE ECN #GRT001328	-	-	-	-

NOTES: UNLESS OTHERWISE SPECIFIED

1. DIMENSIONS AND TOLERANCES PER ASME Y14.5M-1994.
2. * INDICATES DIMENSIONS AND/OR FEATURES MODIFIED ON CURRENT REVISION LEVEL.
3. DIMENSIONS REFLECT STANDARD MFG TOLERANCES.
4. WEIGHTS ARE APPROXIMATE BASED ON MANUFACTURER'S MATERIALS AND PUMP CONFIGURATION

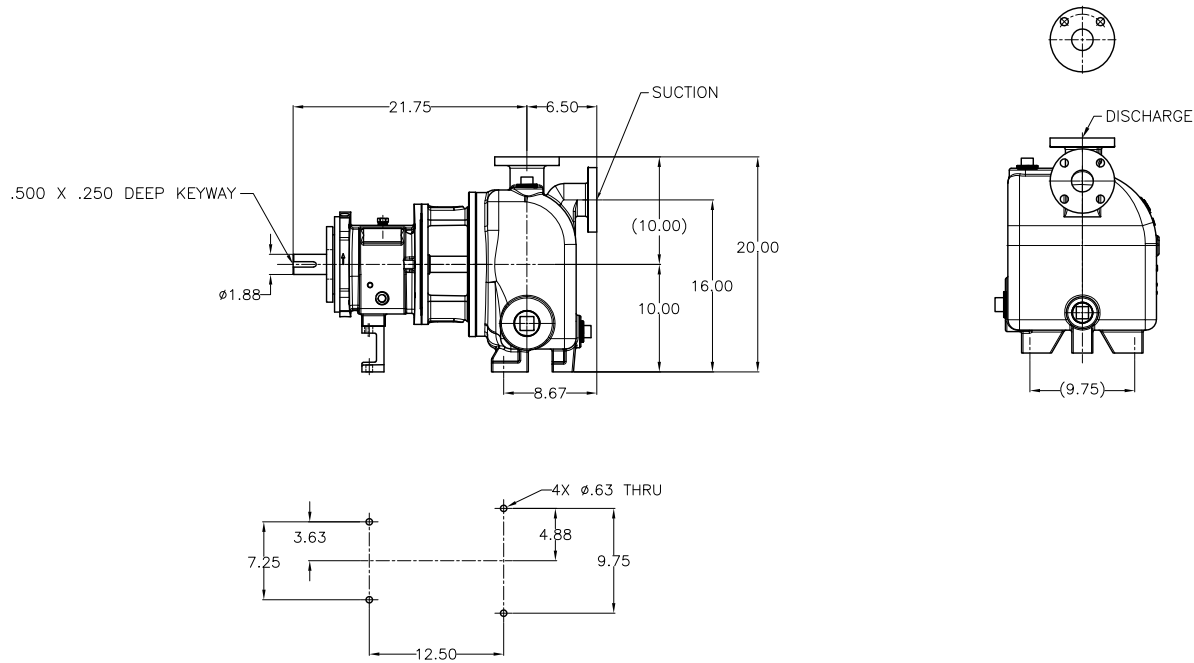

**CERTIFIED
FOR
CONSTRUCTION**

ONLY WHEN SIGNED

Signature _____
Date _____
Customer _____
Customer P.O. # _____

OPTION ✓	AVAILABLE OPTIONS
	PUMP MATERIAL
	X4 CD4MCU SS
	OTHER
	FLANGE FACE
	FLAT FACE
	RAISED FACE

FLANGE OPTION DIMENSIONS

OPTION ✓	NOMINAL PIPE SIZE	FLANGE DIAMETER	BOLT CIRCLE DIAMETER	NO. OF BOLTS	DIAMETER OF BOLTS	BOLT HOLE	FLANGE
	2" ASME 150# (SHOWN)						DISCHARGE
	2.00	6.00	4.75	4	0.63	0.75	
	2" ASME 150# (SHOWN)						SUCTION
	2.00	6.00	4.75	4	0.63	0.75	
	2" ASME 300#						DISCHARGE
	2.00	6.50	5.00	8	0.63	0.75	
	2" ASME 300#						SUCTION
	2.00	6.50	5.00	8	0.63	0.75	

4. PUMP WT.- 351 LBS

DO NOT SCALE DRAWING UNLESS OTHERWISE SPECIFIED DIMENSIONS ARE IN INCHES TOLERANCES ARE:	
DECIMALS .XX ± -	
.XXX ± -	
ANGLES ± -	
SCALE 1/8	SHEET 1 OF 1



GRISWOLD PUMP COMPANY
22060 VAN BUREN STREET
GRAND TERRACE, CA 92313-9907
PHONE: (909) 642-2222 / (209) 526-5555
WWW.GRISWOLDPUMP.COM

TITLE 2 x 2 - 10, 811SP PEO, LG PF			
DRAWN BY R. ANDRADE	DATE 03/05/21	ASSY. NO.	
CHECKED BY T. VOVAN	DATE 03/09/21	DRAWING NO.	
APPROVED BY R. BEACH	DATE 3/30/212	REV.	
		LG1876	A