



REV.	DESCRIPTION	BY	CHK.	APP.	DATE
A	RELEASED INTO PRODUCTION SEE ECN #GRT001328	-	-	-	-

NOTES: UNLESS OTHERWISE SPECIFIED

- DIMENSIONS AND TOLERANCES PER ASME Y14.5M-1994.
- * INDICATES DIMENSIONS AND/OR FEATURES MODIFIED ON CURRENT REVISION LEVEL.
-  DIMENSIONS REFLECT STANDARD MFG TOLERANCES.
-  WEIGHTS ARE APPROXIMATE AND MAY VARY BASED ON MANUFACTURER'S MATERIALS AND PUMP CONFIGURATION.
-  THIS PUMP MAY HAVE TAPPED HOLES IN THE SUCTION FLANGE PER ASME B73.1.

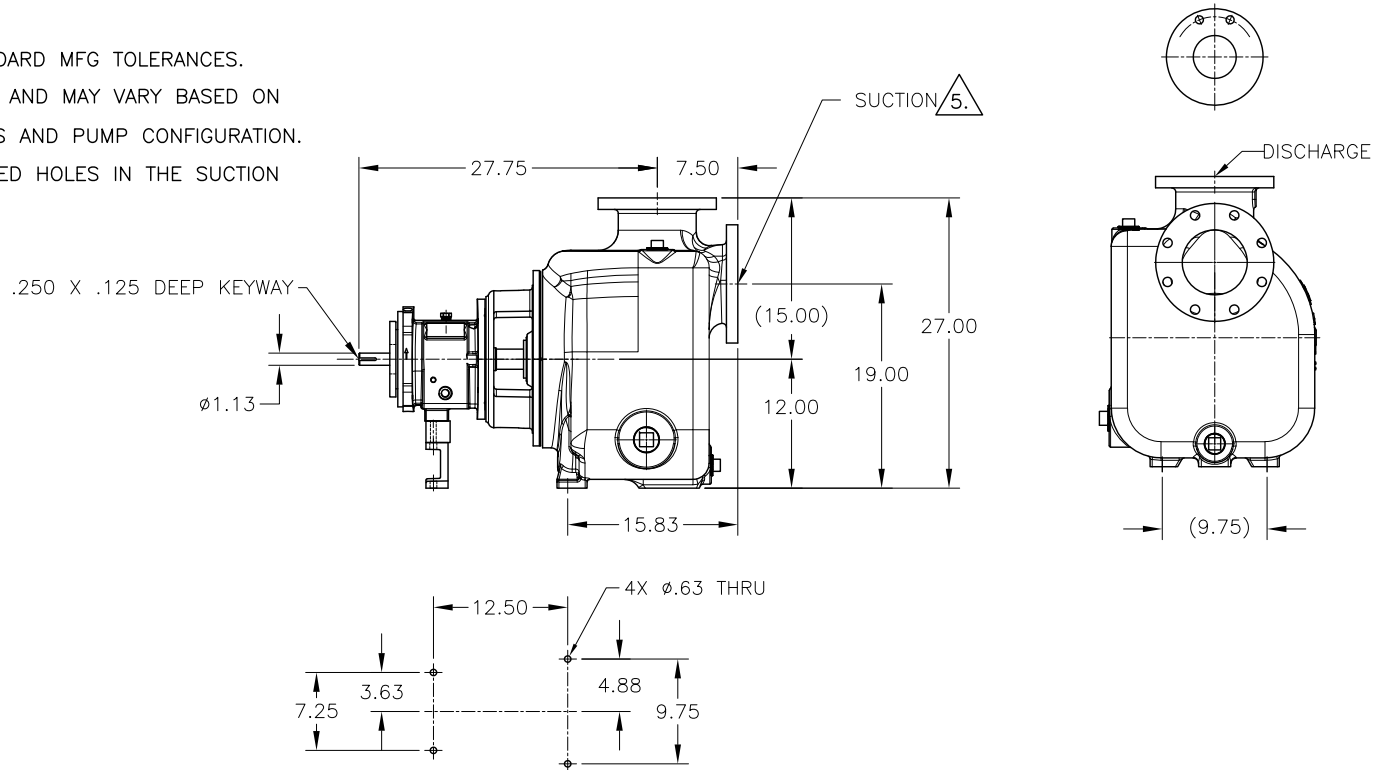

**CERTIFIED
FOR
CONSTRUCTION**

ONLY WHEN SIGNED

Signature _____
Date _____
Customer _____
Customer P.O. # _____

OPTION	AVAILABLE OPTIONS
<input checked="" type="checkbox"/>	PUMP MATERIAL
	X4 CD4MCU SS
	OTHER
	FLANGE FACE
	FLAT FACE
	RAISED FACE

FLANGE OPTION DIMENSIONS

OPTION	NOMINAL PIPE SIZE	FLANGE DIAMETER	BOLT CIRCLE DIAMETER	NO. OF BOLTS	DIAMETER OF BOLTS	BOLT HOLE	FLANGE
<input checked="" type="checkbox"/>	6" ASME 150#						DISCHARGE
	6.00	11.00	9.50	8	0.75	0.88	
<input checked="" type="checkbox"/>	6" ASME 150#						SUCTION
	6.00	11.00	9.50	8	0.75	0.88	
<input checked="" type="checkbox"/>	6" ASME 300#						DISCHARGE
	6.00	12.50	10.62	12	0.75	0.88	
<input checked="" type="checkbox"/>	6" ASME 300# (THD) 						SUCTION
	6.00	12.50	10.62	12	0.75	.750-10 UNC-2B	

 PUMP WT.- 633 LBS

DO NOT SCALE DRAWING UNLESS OTHERWISE SPECIFIED DIMENSIONS ARE IN INCHES TOLERANCES ARE:	
DECIMALS .XX ± -	
.XXX ± -	
ANGLES ± -	
SCALE 1/8	SHEET 1 OF 1



GRISWOLD PUMP COMPANY
22069 VAN BUREN STREET
GRAND TERRACE, CA 92313-9097
PHONE: (909) 942-2022 / (209) 526-5555
WWW.GRISWOLDPUMP.COM

TITLE 6 x 6 - 13, 811SP PEO, MD PF			
DRAWN BY R. ANDRADE	DATE 03/08/21	ASSY. NO.	
CHECKED BY T. VOVAN	DATE 03/09/21	DRAWING NO.	
APPROVED BY R. BEACH	DATE 3/30/21	REV.	
		LG1885 A	

THIS DOCUMENT AND ITS CONTENTS ARE PROPRIETARY TO GRISWOLD PUMP ANY REPRODUCTION, DISCLOSURE OR USE OF THIS DOCUMENT IS EXPRESSLY PROHIBITED EXCEPT AS OTHERWISE AGREED TO IN WRITING.