





B600 Screw Compressor





The Optimum Compact Solution for Mounting Inside Truck Frame

B600-20R:1200 – 2000 rpm CW **B600-30R:**1800 – 3000 rpm CW **Dimensions:**

L 549 x H 348 x W 280 mm

Weight:

94 kg

B600-13R/15L:780 – 1300 rpm CW 
or 900 – 1500 rpm CCW **B600-19R/22L:**1170 – 1950 rpm CW 
or 1320 – 2250 rpm CCW **Dimensions:**

L 686 x H 443 x W 295 mm

Weight:

124 kg

**Flow rates 325 to 600 m³/h**



B600 Screw Compressor

The Optimum Compact Solution for Mounting Inside Truck Frame

Compressor Speed (rpm)

Model	①	②	③	④	⑤
13R	780	910	1040	1170	1300
15L	900	1050	1200	1350	1500
19R	1170	1365	1560	1755	1950
20R	1200	1400	1600	1800	2000
22L	1320	1580	1800	2035	2250
30R	1800	2100	2400	2700	3000

Flow (m³/hr) / Power (kW)

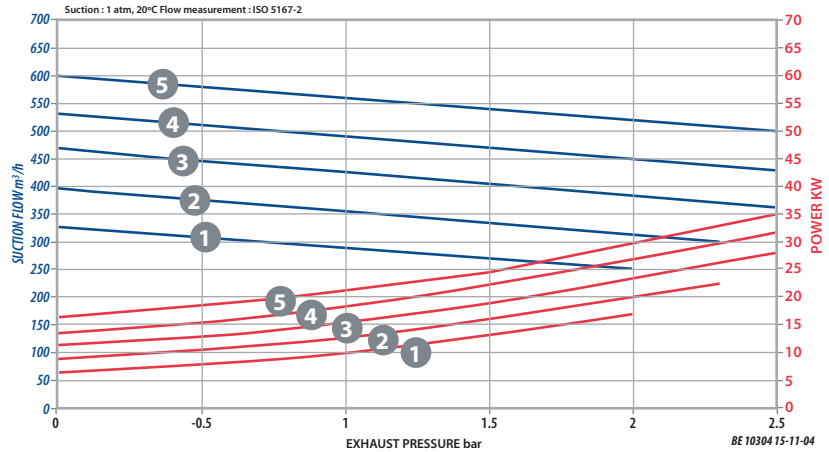

Torque / Pressure (Nm)

Model	Pressure (bar) At Full Speed		
	1.5	2.0	2.5
13R	180	210	260
15L	160	180	220
19R	120	150	170
20R	120	140	170
22L	110	130	150
30R	80	90	110

B600 Screw Compressor 20R and 30R

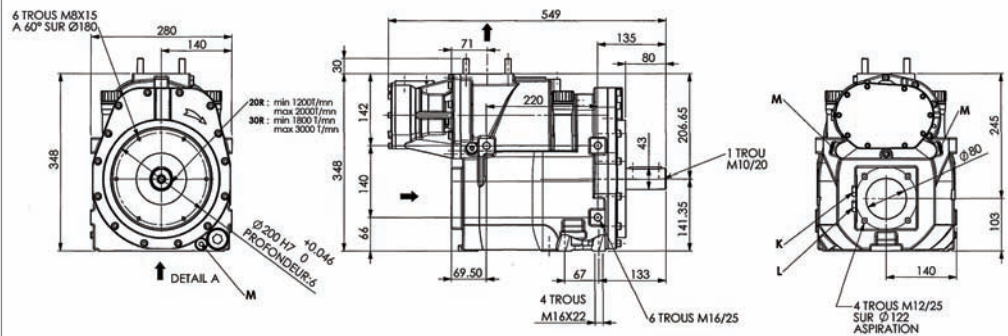

B600 Screw Compressor with Multiplier 13R/15L and 19R/22L

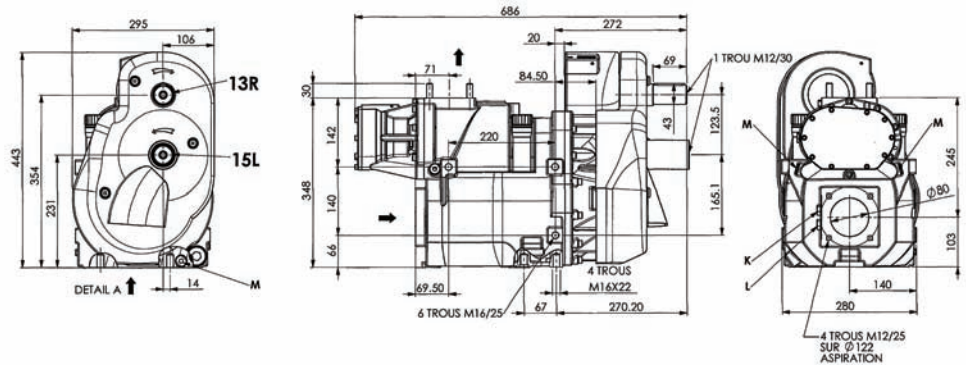

ZI la Plaine des Isles • 2 rue des Caillottes
F-89000 AUXERRE - FRANCE
Tel: + 33.3.86.49.86.30 • Fax: + 33.3.86.46.42.10
contact@mouvex.com
mouvex.com

Authorized PSG® Partner: