



## Compresseur à vis B 600





Le compact – La solution optimale pour un montage intra châssis.

**B600-20R :**1200 – 2000 t/mn CW **B600-30R :**1800 – 3000 t/mn CW **Dimensions (mm) :**

L 549 x H 348 x l 280 mm

**Poids :**

94 kg

**B600-13R/15L :**780 – 1300 t/mn CW   
ou 900 – 1500 t/mn CCW **B600-19R/22L :**1170 – 1950 t/mn CW   
ou 1320 – 2250 t/mn CCW **Dimensions (mm) :**

L 686 x H 443 x l 295 mm

**Poids :**

124 kg

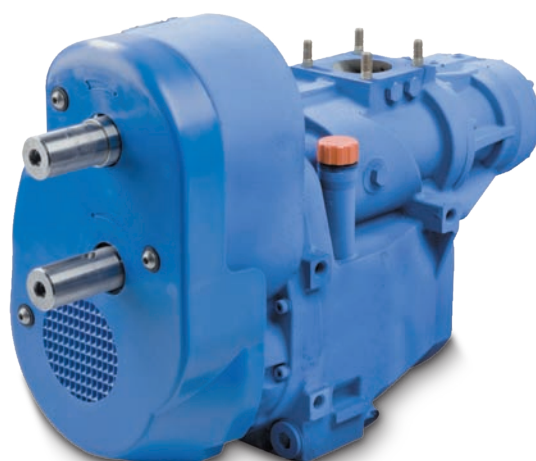

Débits de 325 à 600 m<sup>3</sup>/h



# Compresseur à vis B 600

Le compact – La solution optimale pour un montage intra châssis.

Débit (m<sup>3</sup>/h) / Puissance (kW)

Version	1	2	3	4	5
13R	780	910	1040	1170	1300
15L	900	1050	1200	1350	1500
19R	1170	1365	1560	1755	1950
20R	1200	1400	1600	1800	2000
22L	1320	1580	1800	2035	2250
30R	1800	2100	2400	2700	3000

Débit (m<sup>3</sup>/h) / Puissance (kW)

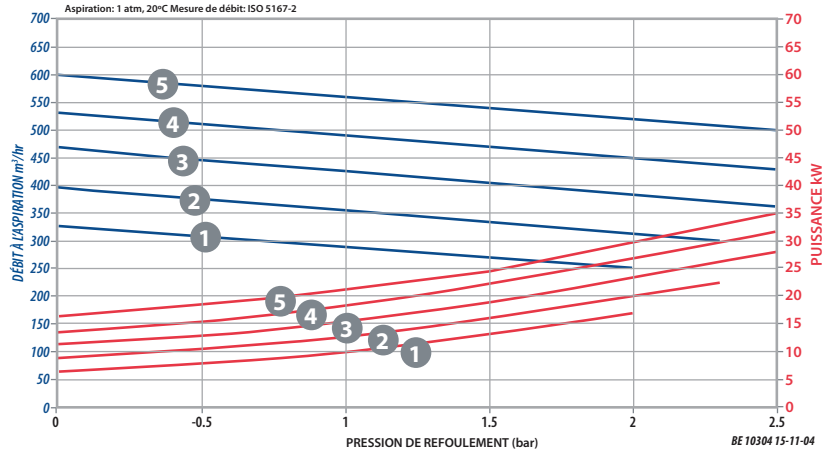

Couple / Pression (Nm)

Version	Pression (bar) À pleine vitesse		
	1.5	2.0	2.5
13R	180	210	260
15L	160	180	220
19R	120	150	170
20R	120	140	170
22L	110	130	150
30R	80	90	110

B600 Compresseur 20R et 30R

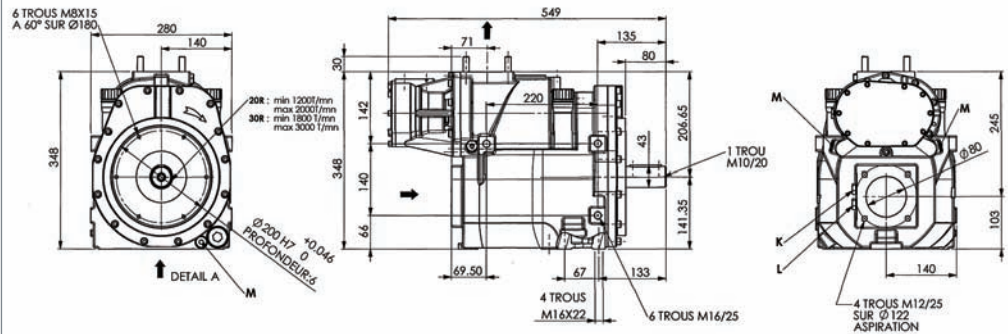

B600 Compresseur avec Multiplificateur 13R/15L et 19R/22L

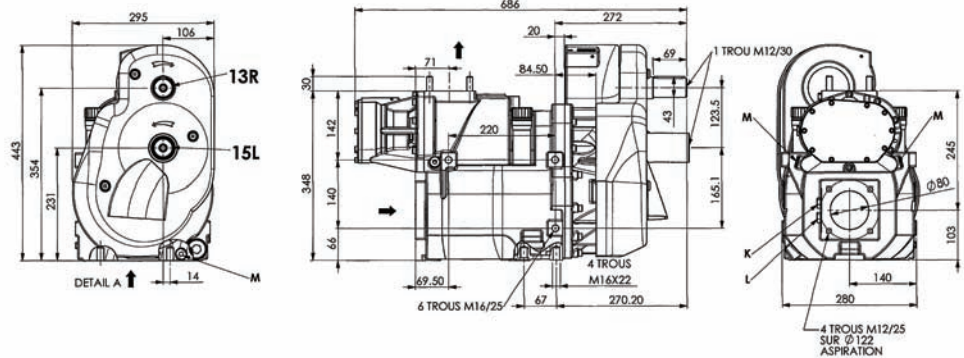

Un flux permanent d'innovations



ZI la Plaine des Isles • 2 rue des Caillottes  
F-89000 AUXERRE - FRANCE  
Tel: + 33.3.86.49.86.30 • Fax: + 33.3.86.46.42.10  
contact@mouvex.com  
mouvex.com

Partenaire de PSG agréé: