

H-FLO Series

SEAL-LESS ECCENTRIC DISC PUMP | PRODUCT BROCHURE

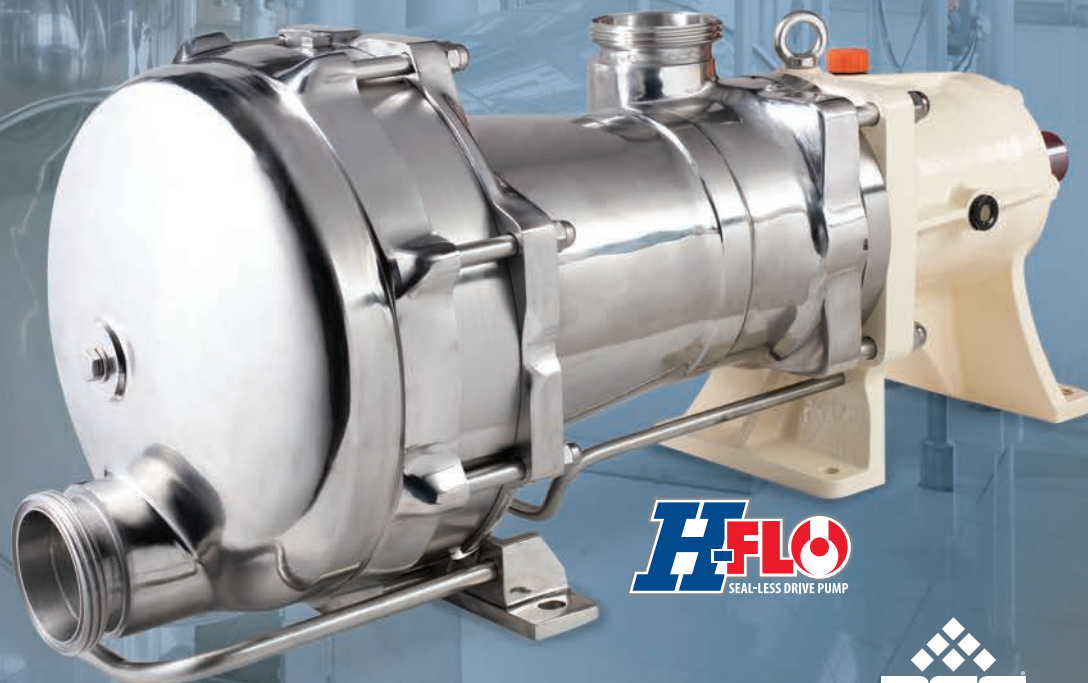

Where Innovation Flows

ENVIRONMENTALLY
FRIENDLY SOLUTION FOR
HYGIENIC APPLICATIONS



H-FLO Series Eccentric Disc Pump

Seal-Less Eccentric Disc Transfer Solution for Hygienic Applications Requiring High Flow Rates



Mouvex® H-FLO Series Seal-Less Eccentric Disc Pumps have been designed for use in a wide range of pumping applications in the food, cosmetic and pharmaceutical industries, all of which require extremely hygienic operations. The H-FLO pump delivers high suction vacuum and high discharge pressure that allow it to self-prime and fully strip lines, a critical consideration when maximizing product recovery.



Applications:

Suitable for most sanitary applications, including food and beverage, pharmaceutical, and cosmetic processes, in particular those that require consistent non-pulsing flow and gentle fluid handling (low shear rate) such as:



FOOD

- Sauce
- Chocolate
- Glucose...



BEVERAGE

- Concentrate
- Glucose
- Fruit Juice
- Flavor
- Alcohol...



DAIRY

- Yogurt
- Ferment
- Dessert
- Yolk...



PHARMACEUTICAL
& COSMETICS

- Ointment
- Syrup
- Cream
- Suppository
- Shampoo...

Seal-less Design

The unique seal-less design features a triple stainless steel bellows that ensures durability, safety and product containment. The H-FLO Series provides high suction vacuum and high discharge pressure, which allows it to self-prime and fully strip lines, maximizing product recovery.

Run Dry Capability

The H-FLO Series can run dry for up to five minutes, and the self-compensating eccentric disc principle provides consistent flow rates over a long period of time. The flow rate is extremely accurate even at low speeds.

Dependable

Fewer moving parts results in reduced maintenance and downtime.

Operation

- **Principle:** Eccentric disc, positive displacement
- **Installation:** Can be base mounted

Construction

- All stainless steel construction
- Shaft sealed by triple stainless steel bellows
- Ra 0.8 µm (32 µ inch) wetted surfaces

Advantages

- Provides consistent and efficient flow with a wide range of viscosities independent of pressure
- Extremely gentle, pulse-free flow to protect shear-sensitive products
- Reduced maintenance with no mechanical seals or timing gears
- Easy to install
- Clean in place (CIP) and sterilize in place (SIP) for the ultimate in convenience and cleanliness
- Eccentric disc design allows for consistent flow and improved energy savings
- Seal-less design eliminates leakage
- Ability to strip and drain transfer piping/tubing
- Self-priming
- Strong suction and discharge pressure
- Flow rate up to 70 m³/h (308.2 gpm), 10 bar (145 psi)
- Low linear speed
- Precise dosing
- Accurate volume metering with high turn down
- Maintains consistent performance over time
- Effective with both high- and low-viscosity fluids
- Full drainability

Options:

- SMS
- DIN 11851
- DIN 11864 BF-A Aseptik fl
- Tri-Clamp® ASME-BPE
- Heating jacket

Mouvex Technology

Eccentric disc pumps consist of a cylinder and pumping element mounted on an eccentric shaft. As the eccentric shaft is rotated, the pumping element forms chambers within the cylinder, which increase in size at the intake port, drawing fluid into the pumping chamber. The fluid is transported to the discharge port where the pumping chamber size is decreased. This action squeezes the fluid out into the discharge piping.

Mouvex Principle

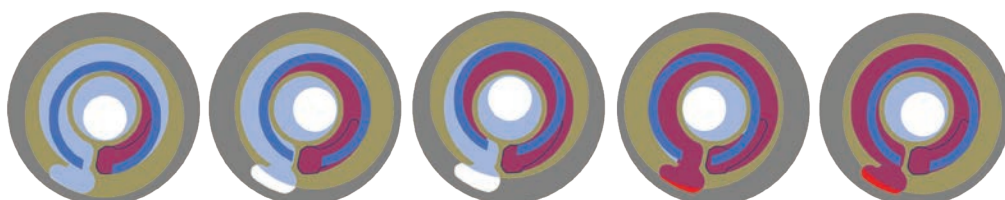

Mouvex® H-FLO Series Eccentric Disc Pump

Shaft

Large diameter single shaft mounted on roller bearings

Bellows

Double or triple bellows ensures total product containment without magnetic drive

- Optional bellows monitoring available

Lubrication

Lubrication by food grade oil

- Oil change every 24,000 hours at <math><80^{\circ}\text{C}</math> (<math><176^{\circ}\text{F}</math>)

Convenience & Cleanliness

Fully drainable and cleanable design. Pumped product in contact with only four (4) components:

- Casing
- Disc and cylinder set
- Bellows
- Few static O-rings

NO bushings, NO mechanical seal, NO magnets

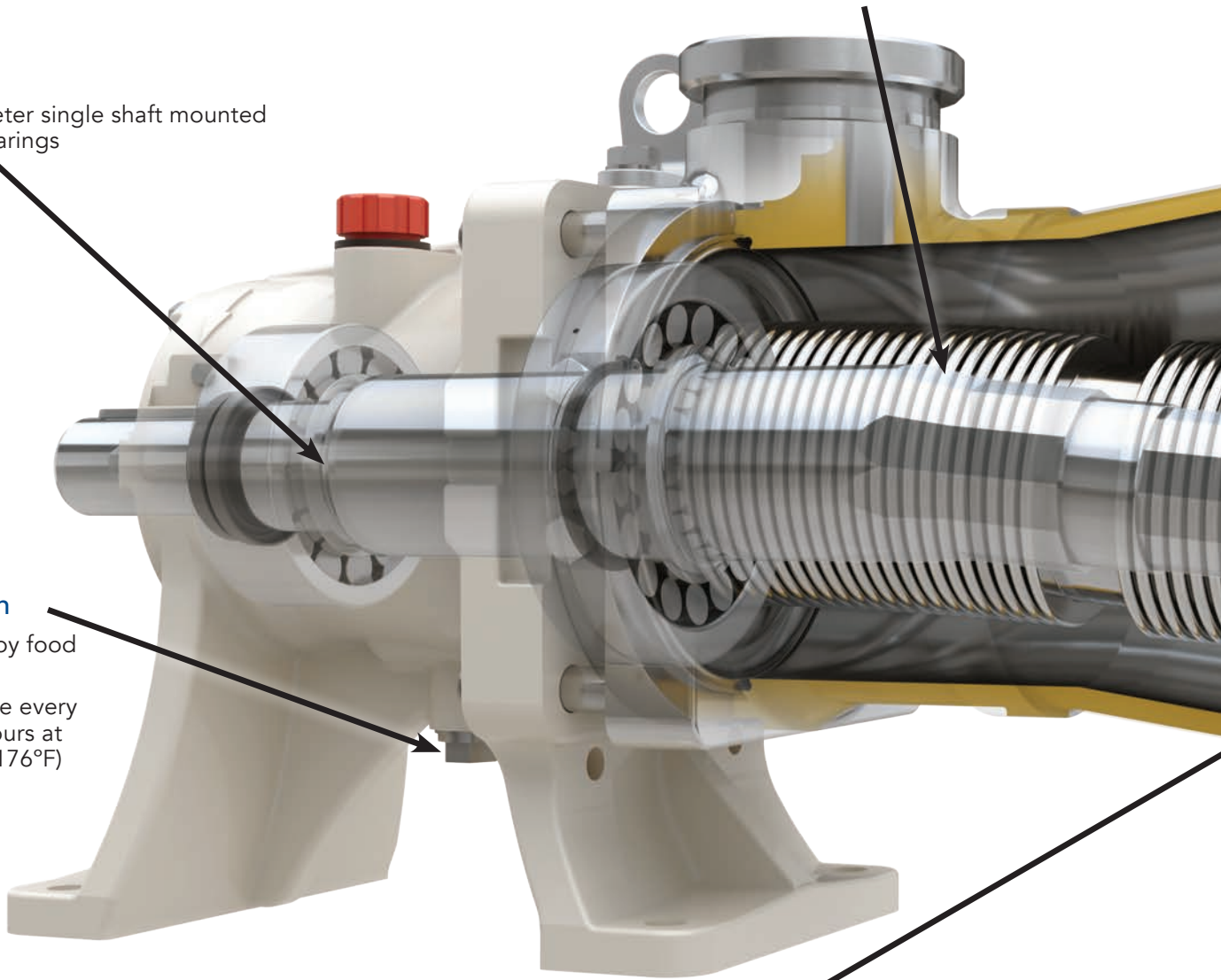

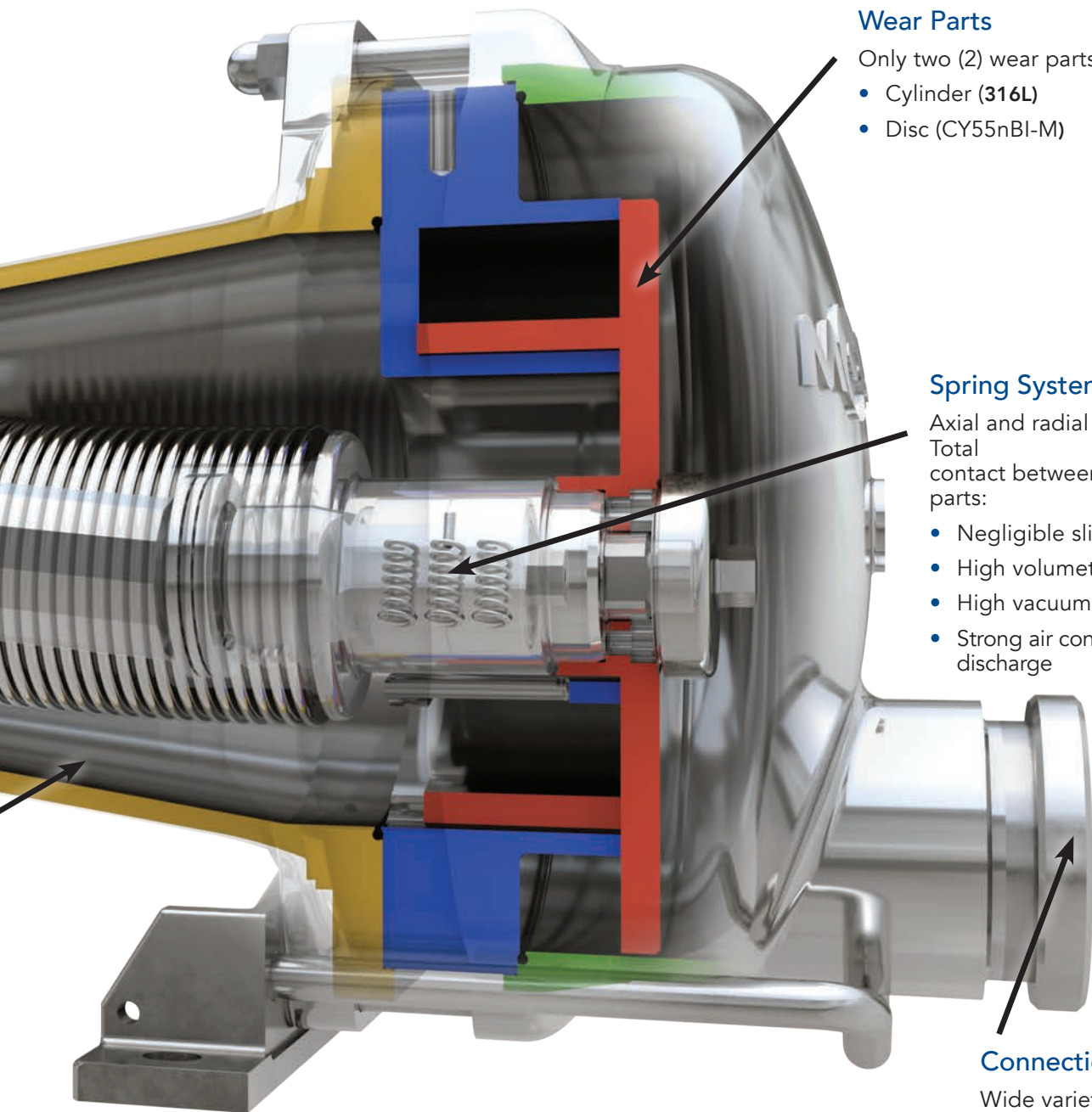

Wear Parts

- Only two (2) wear parts:
- Cylinder (316L)
 - Disc (CY55nBI-M)

Spring System

Axial and radial spring system. Total contact between the pumping parts:

- Negligible slippage
- High volumetric efficiency
- High vacuum on suction
- Strong air consumption on discharge

Connections

Wide variety of connections available:

- ASME-BPE 2009 Clamps
- SMS 1145
- DIN 11851
- DIN 11864 Aseptik
- ISO 2852 Clamps

Mouvex H-FLO Series | Performance Data

PUMP MODEL	MAXIMUM FLOW RATE		MAXIMUM SPEED	MAXIMUM OUTPUT PRESSURE		MAXIMUM TEMPERATURE	
	m ³ /h	gpm	rpm	bar	psi	°C	°F
H-FLO 65-S	70	308.2	350	7	101	100	212
H-FLO 65-HP	54	237.7	350	10	145	100	212
H-FLO 50	55	242.2	400	10	145	100	212
H-FLO 40	43	189.3	460	10	145	100	212
H-FLO 25	27.5	121.1	525	10	145	100	212



Mouvex H-FLO Series | Dimensions

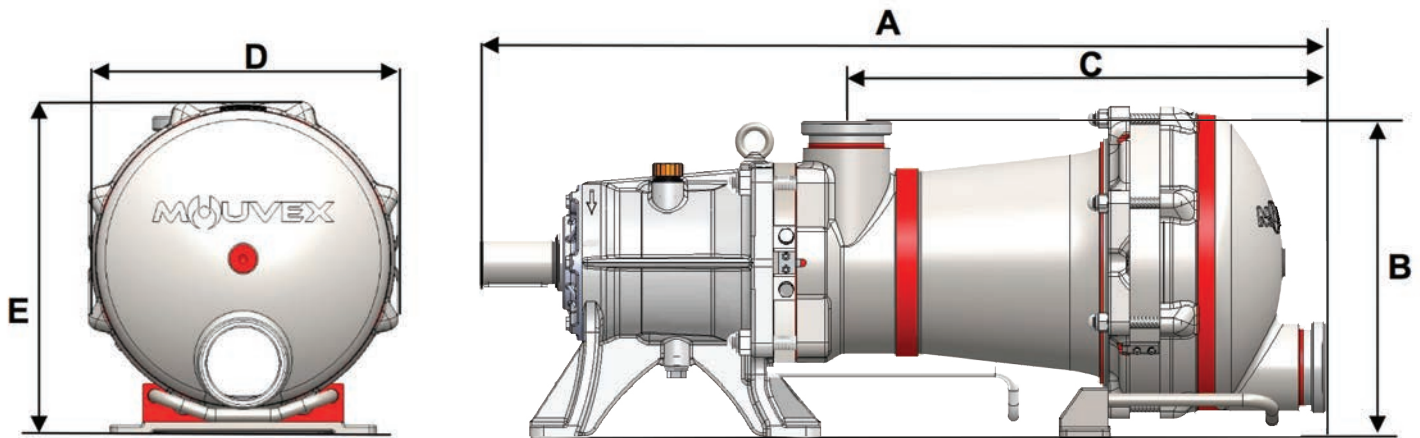

PUMP MODEL	DN mm (in)	A mm (in)	B mm (in)	C mm (in)	D mm (in)	E mm (in)	Weight kg (lbs)
H-FLO 65-S	100 (3.94)	1177 (46.34)	434 (17.03)	672.5 (26.48)	448 (17.64)	464 (18.27)	321 (708)
H-FLO 65-HP	100 (3.94)	1177 (46.34)	434 (17.03)	672.5 (26.48)	448 (17.64)	464 (18.27)	315 (695)
H-FLO 50	100 (3.94)	1066.5 (41.99)	400 (15.75)	623 (24.53)	410 (16.14)	425 (16.73)	225 (497)
H-FLO 40	76 (3)	1023 (40.28)	386.5 (15.22)	591 (23.67)	354 (13.94)	372 (14.65)	175 (386)
H-FLO 25	76 (3)	872 (34.33)	346 (13.59)	518.5 (20.41)	304 (11.97)	327 (12.87)	122 (269)

(With SMS Connections)



PSG
ZI la Plaine des Isles
2 rue des Caillottes
F-89000 Auxerre, France
P: +33 (0) 3 86 49 86 30
contact.mouvex@psgdover.com
psgdover.com/mouvex



Where Innovation Flows

MX-10510-C-04-A4

Authorized PSG® Partner:

Copyright 2022 PSG®, a Dover company