



MISTRAL Screw Compressor

Le spécialiste – La solution optimale pour un montage intra châssis

MISTRAL-20R :

1200 – 2000 t/mn CW 

MISTRAL-30R :

1800 – 3000 t/mn CW 

Dimensions (mm) :

L 587 x H 355 x l 280 mm

Poids :

115 kg

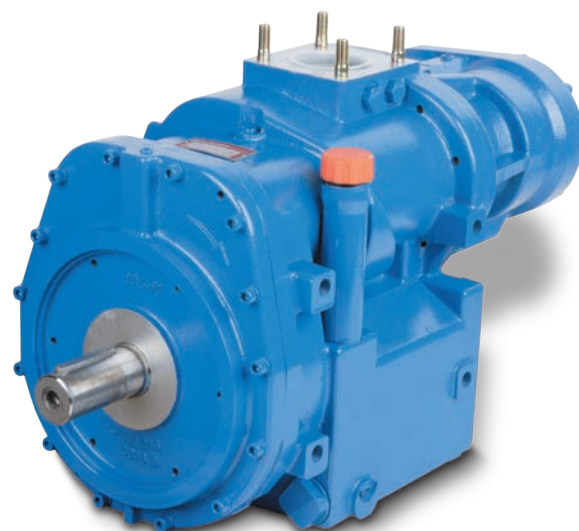

MISTRAL-13R/15L :

Non plus 780 – 1300 t/mn CW 

ou 900 – 1500 t/mn CCW 

MISTRAL-19R/22L :

Non plus 1170 – 1950 t/mn CW 

ou 1320 – 2250 t/mn CCW 

Dimensions (mm) :

L 723 x H 442 x l 295 mm

Poids :

145 kg

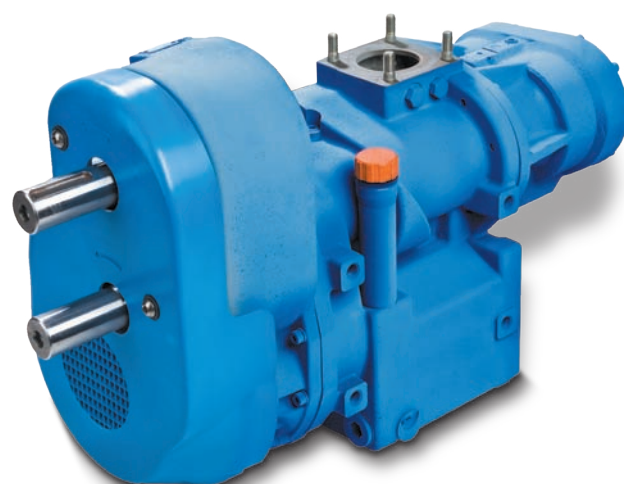

Débits de 365 à 750 m³/h



MISTRAL Screw Compressor

Le spécialiste – La solution optimale pour un montage intra châssis

Vitesse du Compresseur (t/mn)

Version	1	2	3	4	5
13R	780	910	1040	1170	1300
15L	900	1050	1200	1350	1500
19R	1170	1365	1560	1755	1950
20R	1200	1400	1600	1800	2000
22L	1320	1580	1800	2035	2250
30R	1800	2100	2400	2700	3000

Débit (m³/h) / Puissance (kW)

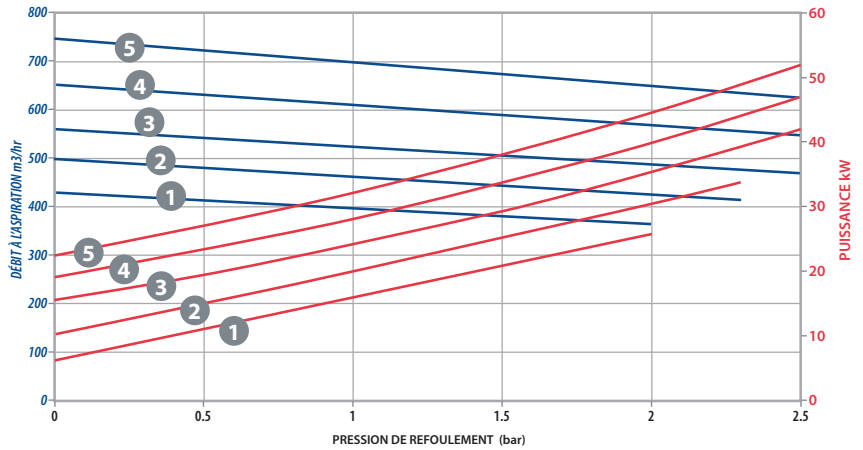

Couple / Pression (Nm)

Version	Pression (bar) À pleine vitesse		
	1.5	2.0	2.5
13R	280	320	380
15L	240	280	330
19R	190	220	260
20R	180	210	250
22L	160	190	230
30R	120	140	170

MISTRAL Compresseur 20R et 30R

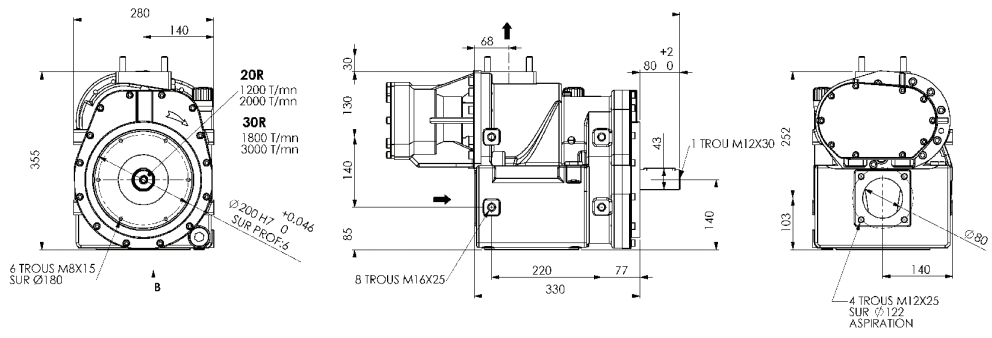

MISTRAL Compresseur avec Multiplicateur 13R/15L et 19R/22L

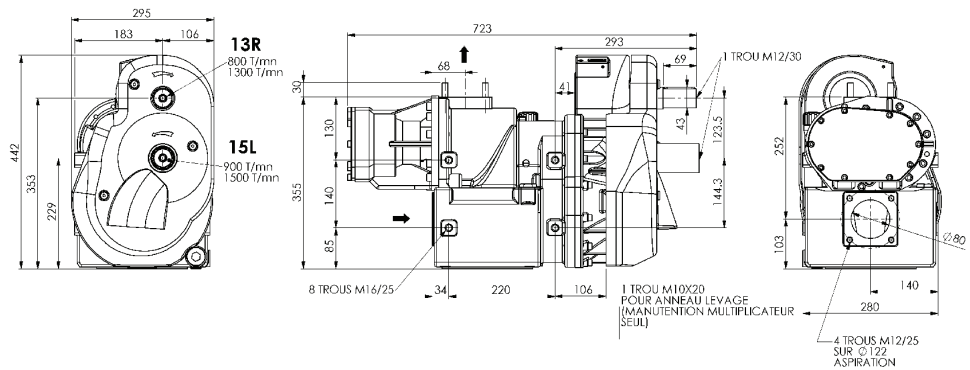

Un flux permanent d'innovations



ZI la Plaine des Isles • 2 rue des Caillottes
F-89000 AUXERRE - FRANCE
Tel: + 33.3.86.49.86.30 • Fax: + 33.3.86.46.42.10
contact@mouvex.com
mouvex.com

Partenaire de PSG agréé: