



Compressore a vite MISTRAL





La soluzione multiuso per il montaggio all'interno del camion telaio

MISTRAL-20R:1200 – 2000 giri/min D **MISTRAL-30R:**1800 – 3000 giri/min D **Dimensioni :**

L 587 x A 355 x P 280 mm

Peso :

115 kg

MISTRAL-13R/15L:Uno 780 – 1300 giri/min D 
o 900 – 1500 giri/min S **MISTRAL-19R/22L:**Uno 1170 – 1950 giri/min D 
o 1320 – 2250 giri/min S **Dimensioni :**

L 723 x A 442 x P 295 mm

Peso :

145 kg

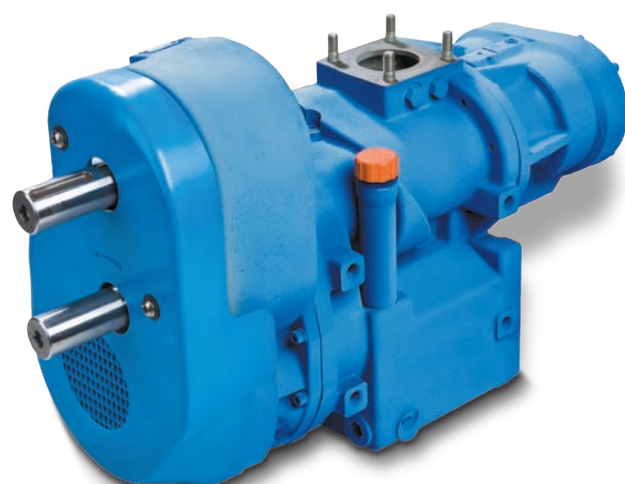
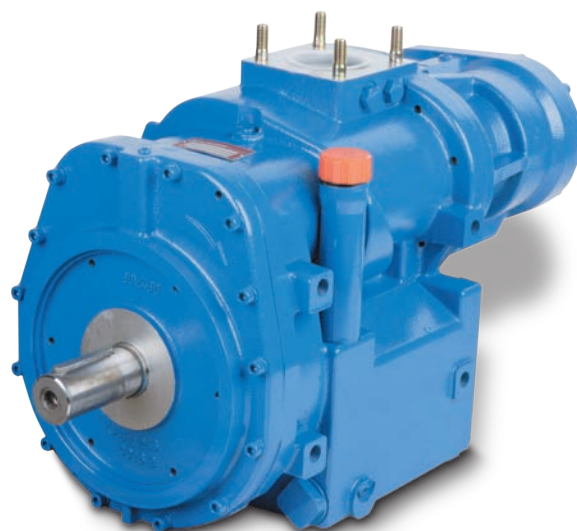

Da 365 to 750 m³/ora



Compressore a vite MISTRAL

La soluzione multiuso per il montaggio all'interno del camion telaio

Velocità Del Compressore (giri/min)

Versione	1	2	3	4	5
13R	780	910	1040	1170	1300
15L	900	1050	1200	1350	1500
19R	1170	1365	1560	1755	1950
20R	1200	1400	1600	1800	2000
22L	1320	1580	1800	2035	2250
30R	1800	2100	2400	2700	3000

Portata (m³/ora) / Potenza (kW)

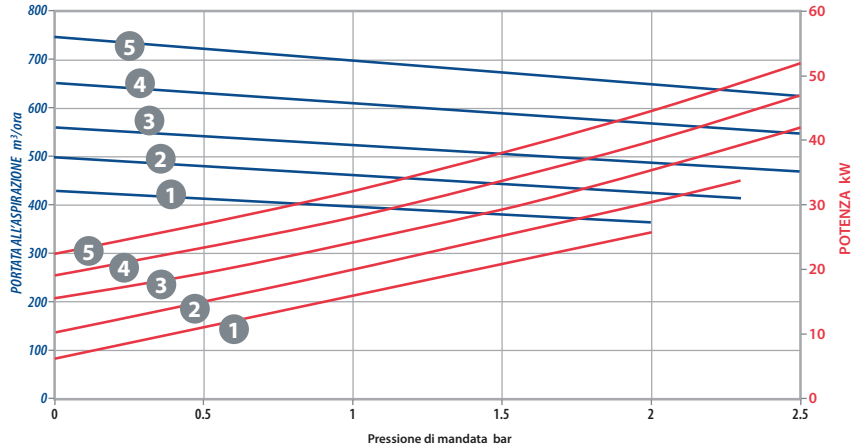

Coppia / Pressione (Nm)

Versione	Pressione (bar) a piena velocità		
	1.5	2.0	2.5
13R	280	320	380
15L	240	280	330
19R	190	220	260
20R	180	210	250
22L	160	190	230
30R	120	140	170

MISTRAL Compressore 20R and 30R

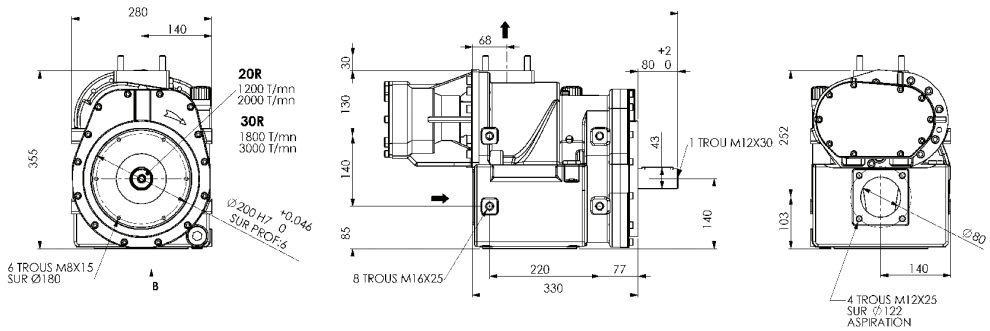

MISTRAL Compressore + Invertitore 13R/15L and 19R/22L

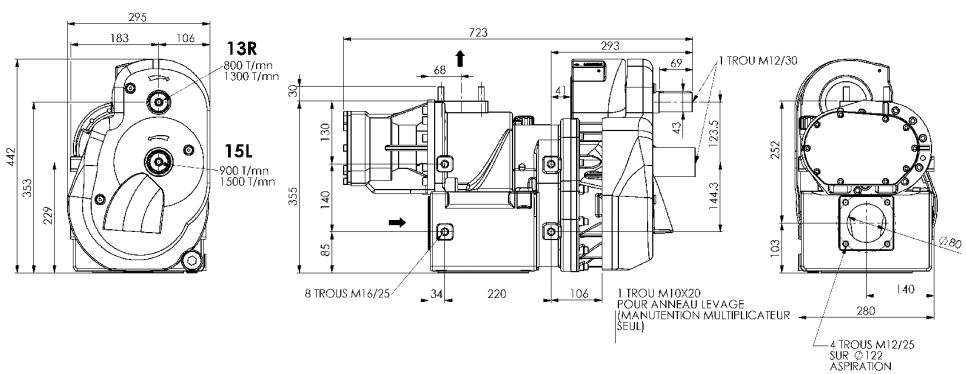

ZI la Plaine des Isles • 2 rue des Caillottes
 F-89000 AUXERRE - FRANCE
 Tel: + 33.3.86.49.86.30 • Fax: + 33.3.86.46.42.10
 contact@mouvex.com
 mouvex.com

Autorizzato PSG® Partner: