



## HYDRIVE Series Hydraulic Cooler, the Mouvex Solution

The **Hydrive** is used on Hydraulic drive for pumps and compressors, it integrates 3 functions:

- Oil tank
- Oil cooler
- Security relief valve

### UNIQUE DESIGN

- Compact size allows for easy installation on tractors and trucks with minimal space on chassis rails. The compact design with a low noise level centrifugal fan provides maximum performance and heat dissipation up to 13.5HP (10kW) on 2010 models and 26 HP (20kW) on 2020 models.

### BUILT FOR PERFORMANCE

- Constructed from stainless steel materials to withstand the harsh environmental and operation conditions. The light weight cooler with a small hydraulic oil reservoir, reduces the concern and hazard of costly spills.

### MAINTENANCE FRIENDLY

- The easy to read restriction gauge mounted on the front of the Hydrive indicates when the spin-on oil filter should be replaced. Normal hydraulic oil maintenance is made easy with the reservoir drain on the Hydrive tank.

### OPTIONS AND ACCESSORIES

- Complete Hydraulic System Packages
- Hydraulic Motor Adapters for Mouvex Pumps



*Fitting under the frame*

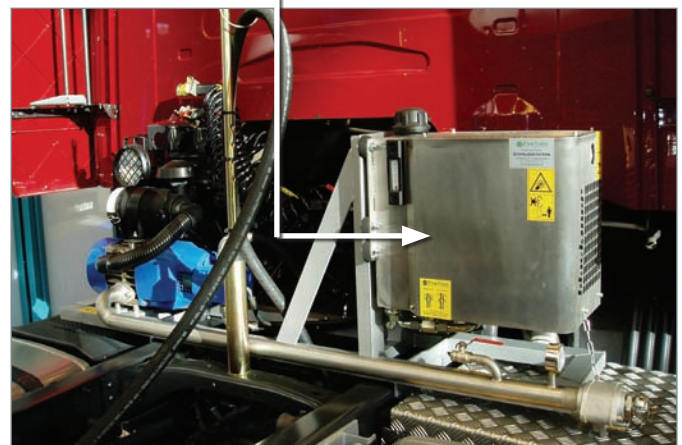

*Fitting on the frame*

Up to 200 L/min and 280 bar



# HYDRIVE Series Hydraulic Cooler, the Mouvex Solution

## Hydrive 2010

Operations Parameters		
Oil Flow Rate	15 - 32 US GPM	55 - 120 L/min
Circuit Pressure	725 - 4061 PSI	50 - 280 BAR
Fan Speed	2800 RPM	
Return Pressure	15 - 75 PSI	1 - 5 BAR
Heat Dissipation	13,5 HP for 70° F Temp. Rise	10 kW for 40° C Temp. Rise
Fan Motor Flow	1.5 US GPM	5.5 L/min
Weight (dry)	53 lbs	24 kg
Oil Tank Capacity	2.5 US Gallons	10 Liters

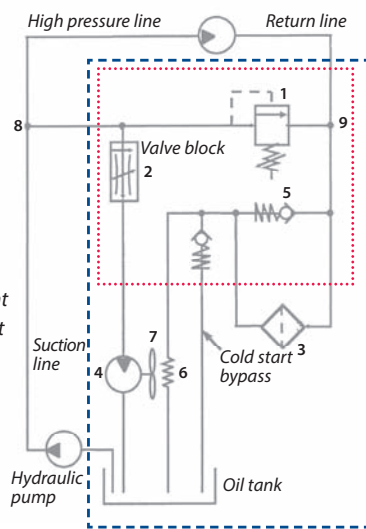

1. Adjustable relief valve
2. Fan speed control valve
3. Return line filter
4. Fan motor
5. Filter by-pass valve
6. Oil cooler radiator
7. Fan
8. System pressure gauge point
9. Return pressure gauge point

--- Hydrive  
 ..... Valve block

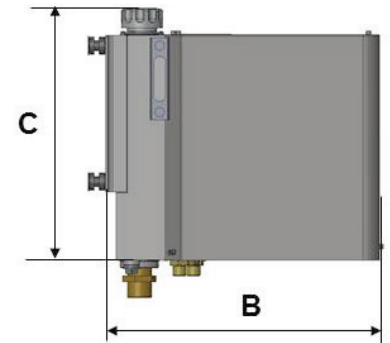
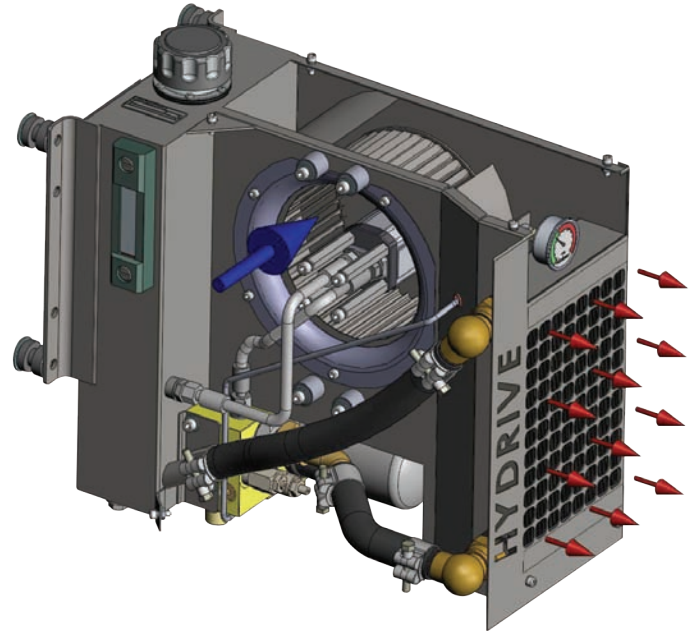

Hydrive	A	B	C
2010	278 mm	526 mm	498 mm
2020	428 mm	559 mm	566 mm

## Hydrive 2020

Operations Parameters		
Oil Flow Rate	15 - 53 US GPM	55 - 200 L/min
Circuit Pressure	725 - 4061 PSI	50 - 280 BAR
Fan Speed	2800 RPM	
Return Pressure	15 - 75 PSI	1 - 5 BAR
Heat Dissipation	26 HP for 70° F Temp. Rise	20 kW for 40° C Temp. Rise
Fan Motor Flow	2.2 US GPM	8.2 L/min
Weight (dry)	77 lbs	35 kg
Oil Tank Capacity	4.5 US Gallons	17 Liters

## Sales Information and Equipment Application Assistance

- Mouvex has a world wide distribution network to assist you in specifying any of our family of pumps, compressors and other equipment for your application.
- For more information or to find the distributor nearest to you, please contact us as the telephone, fax or internet address listed below.



ZI la Plaine des Isles • 2 rue des Caillottes  
 F-89000 AUXERRE - FRANCE  
 Tel: + 33.3.86.49.86.30 • Fax: + 33.3.86.46.42.10  
 contact@mouvex.com  
[mouvex.com](http://mouvex.com)

Authorized PSG® Partner: