

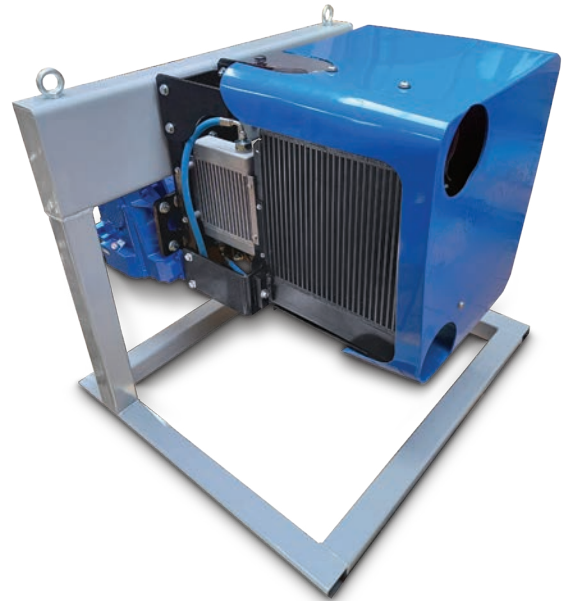

MX12 Screw Compressor Package - DDIC Direct-Drive, Inter-Cooled Systems

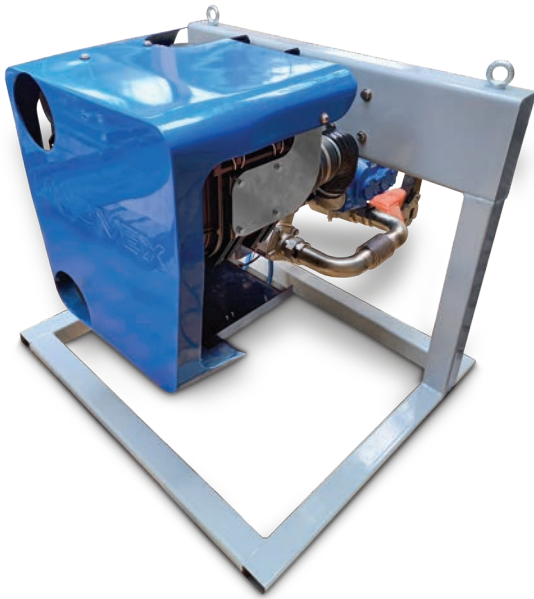

Mouvex® has developed inter-cooled modular screw compressor systems fitted with common accessories for PTO direct-drive systems that can be mounted inside the truck frame.

Features

- System designed to fit trucks with a wheelbase length from 3.50 m
- Versatile systems for clockwise or counter-clockwise drive

Systems designed for Mouvex screw compressors:

- MX12



MX12
500 - 1,130 m³/h

mx12»

Length: 625 mm, Height: 695 mm, Width: 780* mm

*Compatible with the side panels



MX12 Screw Compressor Package - DDIC

Direct-Drive, Inter-Cooled Systems

Compressor Model		MX12
Version		Version S 15R 18L 20R 24L
Flow	m ³ /h	500 - 1130
Weight	kg	250
Height (H) - Maximum	mm	695
Length (L)	mm	625
Width (W)	mm	780
Compressor Length (C)	mm	549

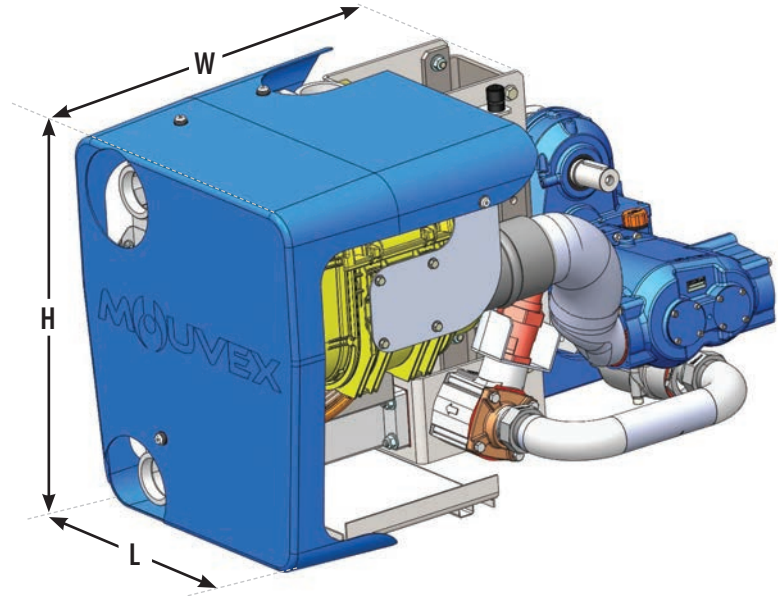

Version S PTO Driven

Rotation Direction	Type
Clockwise	15R – 20R
Counter-Clockwise	18L – 24L

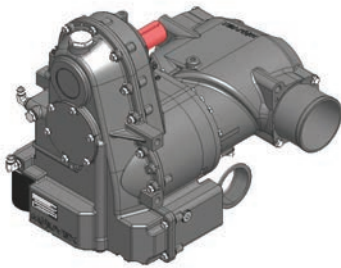

15R/CW	860 - 1,440 rpm
18L/CCW	1,030 - 1,736 rpm
20R/CW	1,150 - 1,920 rpm
24L/CCW	1,380 - 2,300 rpm

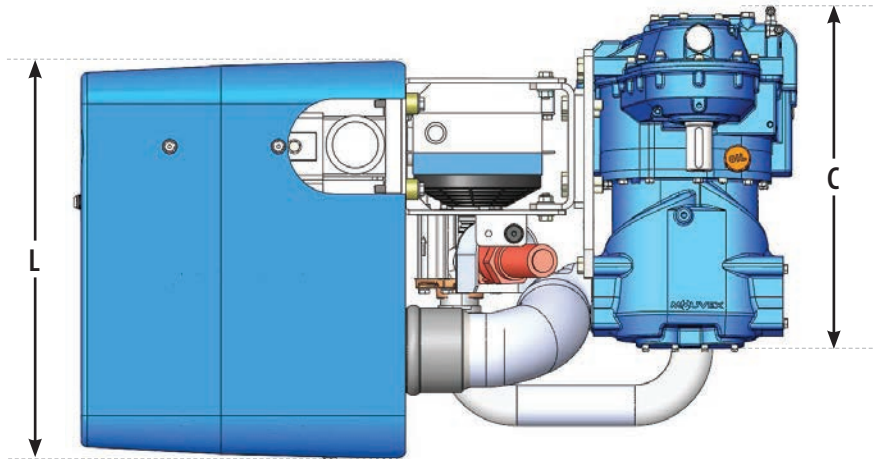

MOUVEX

ZI la Plaine des Isles • 2 rue des Caillottes
F-89000 AUXERRE - FRANCE
Tel: + 33.3.86.49.86.30 • Fax: + 33.3.86.46.42.10
contact.mouvex@psgdover.com
psgdover.com/mouvex

Authorized PSG® Partner:

