







# The MX12

Performance Towards Excellence

## Advantages:

-  The lightest compressor on the market in its category – 110 kg (242 lbs)
-  Modular design: Easy to repair, modify, or upgrade
-  Compact design with the reliability of the Mouvex® Typhon II
-  Cardan angle reduction
-  Compatible with 6x2 trucks, considering an intra-frame assembly
-  Reduced fuel consumption (lower inlet speed)
-  Quiet Operation – Reliably high air pressures with no vibration for reduced noise levels
-  Flow rate up to 1,130 m<sup>3</sup>/h

## Applications:

- Plastics
- Gravel
- Animal Food
- Cereals
- Lime

## Mouvex® MX12 Screw Compressor

The Excellent Solution for  
Mounting Inside the Truck Frame

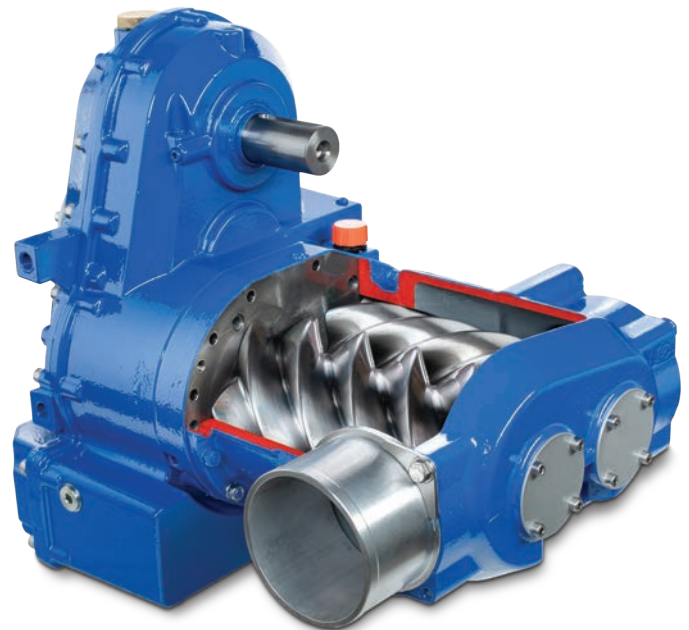

Where Innovation Flows





# MX12 Screw Compressor

## Modular Design

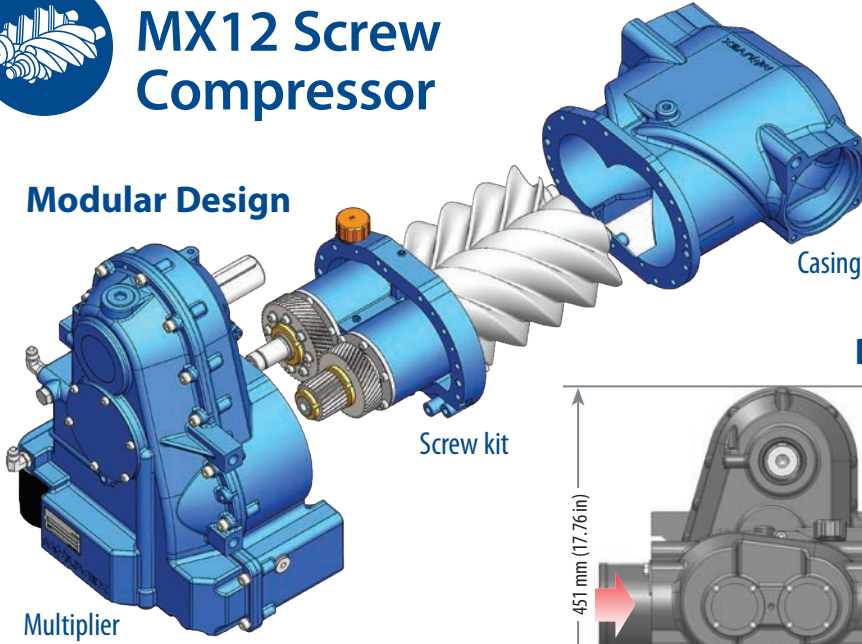

## Dimensions

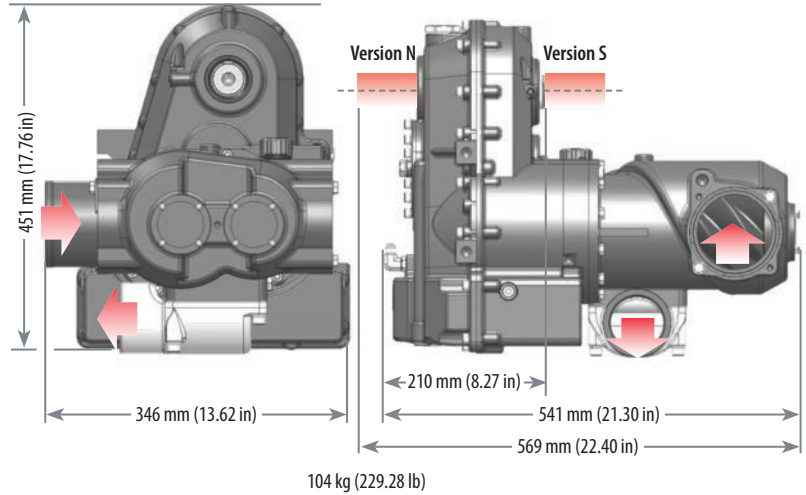

## Version S PTO Driven

Rotation Direction	Type
Clockwise	15R – 20R
Counter-Clockwise	18L – 24L

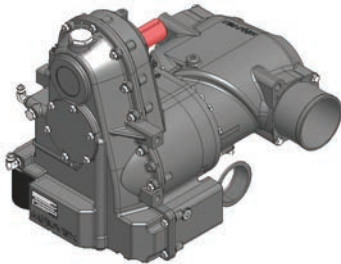

## Version N External Engine Driven

Rotation Direction	Type
Clockwise	18R – 24R
Counter-Clockwise	15L – 20L

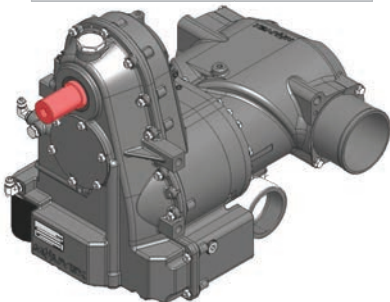

## Performance Curves (Suction atm, 20°C)

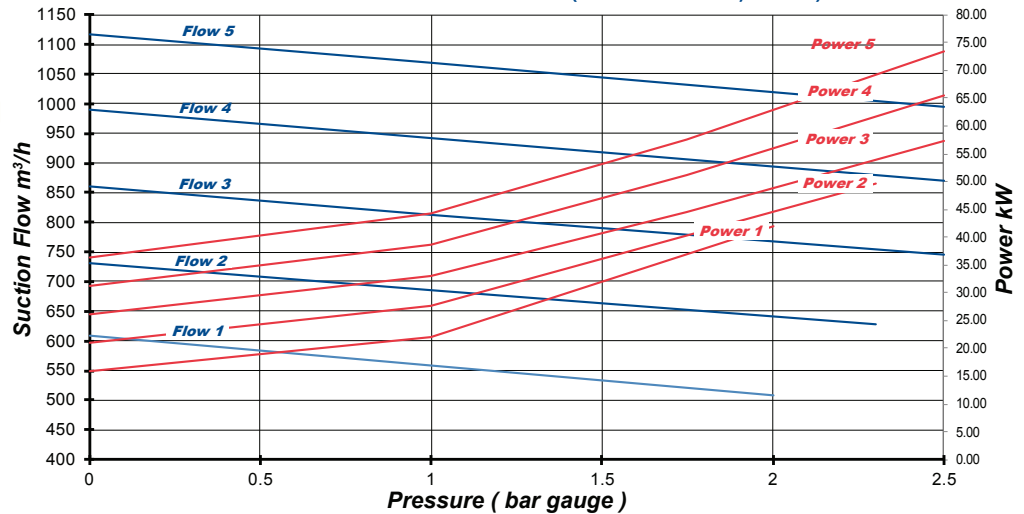

Version	1	2	3	4	5
15	862	1006	1151	1296	1439
18	1034	1208	1382	1556	1727
20	1150	1343	1536	1730	1920
24	1377	1608	1840	2072	2300



MOVEX® reserves the right to modify the information and illustrations contained in this document without prior notice. This is a non-contractual document. 10-2020



ZI la Plaine des Isles • 2 rue des Caillottes  
 F-89000 AUXERRE - FRANCE  
 Tel: + 33.3.86.49.86.30 • Fax: + 33.3.86.46.42.10  
 contact.mouvex@psgdover.com  
 mouvex.com

Authorized PSG® Partner: