



INSTRUCTIONS 1010-B00 e

Section	1010
Effective	November 2017
Replaces	May 2014

Translation of the
original instructions

TANK TRUCK PUMPS
CC8 - CC10 - CC20
(driven by the power take off)

INSTALLATION



Z.I. La Plaine des Isles - F 89000 AUXERRE - FRANCE
Tel. : +33 (0)3.86.49.86.30 - Fax : +33 (0)3.86.49.87.17
contact@mouvex.com - www.mouvex.com

Your distributor :

PUMP SHAFT AND PTO SHAFT ARE PARALLEL

A An imperfect mounting will obviously give pulsations and vibrations to the installation and even can breake the pumping unit (pump, transmission, PTO...).

All the following conditions must be strictly respected :

- 1) Pump shaft is to be parallel with the PTO shaft
- 2) The angle between both shafts and transmissions must not exceed 15°
- 3) The transmission shaft must slide properly when running
- 4) Jaws of cardan must be parallel.
- 5) Coupling flanges must show neither excentricity nor buckling of the contact face.

Figure 1

P : PTO

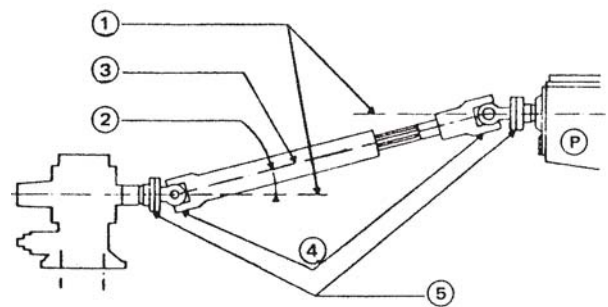

B Mounting (parallel shafts) checking by means of MOUVEX equipments.

Figure 2

P : PTO

1/ Checking equipments

2/ Yoke

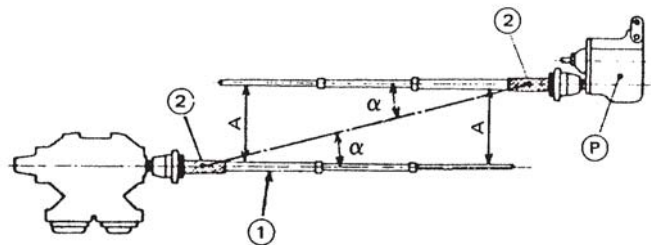

A distances must be equal and the α angle less or equal to 15° .

PUMP SHAFT AND PTO SHAFT ARE NOT PARALLEL

A The recommended mounting on Figure 1 is the most simple and the cheapest. However, if impossible, it can be replaced by following one :

Figure 3

P : PTO

- 1/ Converging shafts
- 2/ Angles less or equal to 15°

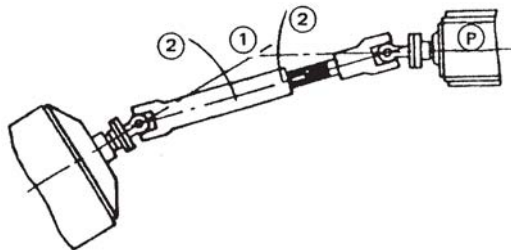

Figure 4

P : PTO

- 1/ Homokinetic double coupling
- 2/ 45° angle maxi
- 3/ Pump shaft and transmission in line

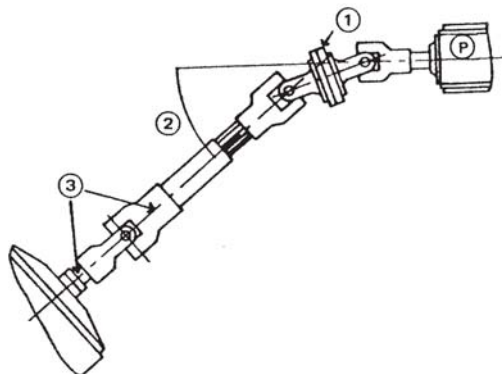

Figure 5

P : PTO

- 1/ Homokinetic double coupling
- 2/ 45° angle maxi
- 3/ 15° angle maxi

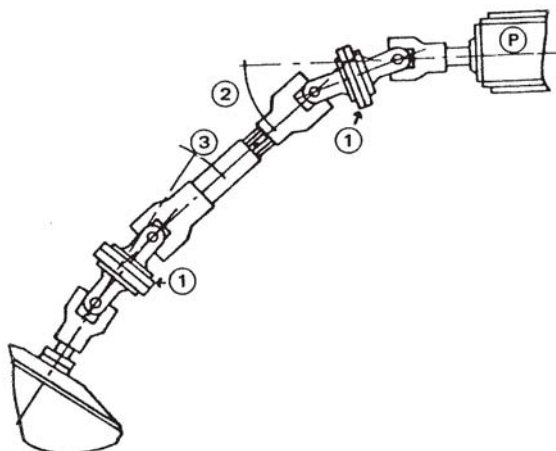
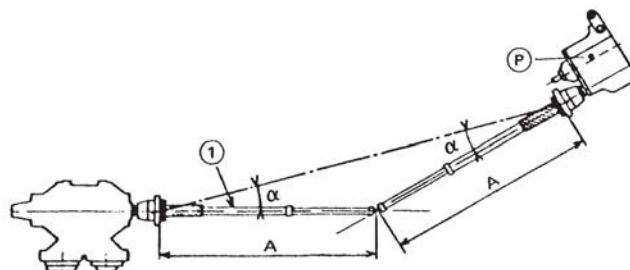

Figure 6

P : PTO

- 1/ Checking equipments



A distances must be equal and the α angle less or equal to 15°.