



INSTRUCTIONS 1005-B00 e

Section	1005
Effective	April 2023
Replaces	September 2018

Translation of the original instructions

Pump AG H

INSTALLATION

OPERATION

MAINTENANCE

EC CERTIFICATE OF CONFORMITY :

The EC Certificate of Conformity (paper version) is systematically attached to the equipment when shipped.

WARRANTY :

TM Series pumps are covered 24 months by warranty within the limits mentioned in our General Sales Conditions. In case of a use other than that mentioned in the Instructions manual, and without preliminary agreement of MOUVEX, warranty will be canceled.



Z.I. La Plaine des Isles - F 89000 AUXERRE - FRANCE
Tel. : +33 (0)3.86.49.86.30 - Fax : +33 (0)3.86.49.87.17
contact.mouvex@psgdover.com - www.mouvex.com

Your distributor :

INSTALLATION

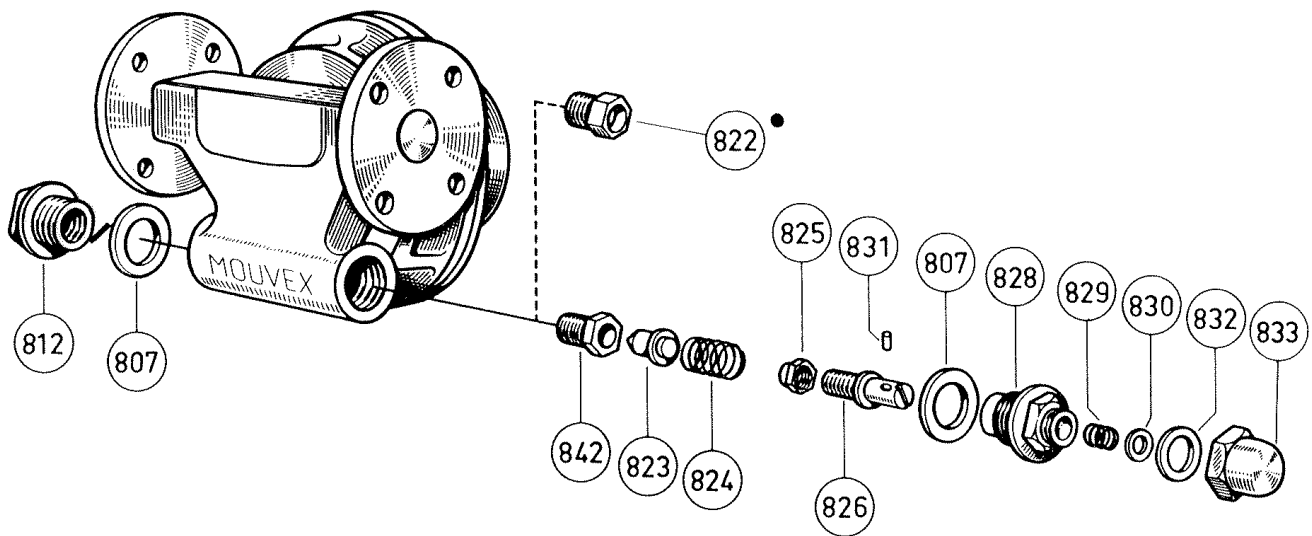

- In compensated bypass, special seat 822 substituted to standard 842.

Piping assembly

For hoses fitting on pump suction or discharge, a hose whip restrain device must be installed to limit the whip or travel of the pressurized hose at start up, or in case the hose breaks free.



Rotation

MOUVEX pump is reversible. Suction and discharge ends are bound to rotation as indicated on plate fixed to pump.

Motor protection

As the bypass protects the pump only, electric motors should be equipped with their own protection device.

Bypass orientation

Functioning

Acting as a relief valve, the MOUVEX bypass protects pump and auxiliary equipment from damage due to excessive pressures that may be built up when the pump runs against some obstruction in the discharge piping.

When discharge pressure reaches the pressure limit for which the bypass is set, the valve opens and thus allows the liquid to be circulated from the suction side back to the suction side.

Orientation

The bypass protects the pump in one direction of rotation only. Therefore make sure it is rightly installed by checking that bypass cap is on the suction side and reverse bypass if necessary.

Reversing

Remove nut **828** and parts coming with it.

Remove valve **823**, spring **824** and fit those parts on the opposite side.

Fit plug **812** and gasket **807** in the place of nut **828**.

In special low-pressure bypass, seat **822** must be reversed.

OPERATION

Pressure setting

To set bypass, remove cap **833**.

To increase pressure setting, turn adjusting screw **826** clockwise.

To reduce pressure setting, turn the nut counterclockwise.

Replace cap **833**.

Delivery adjustment

When the pump does not deliver the proper flowrate, the trouble may come from bypass spring not being adjusted at the correct pressure setting.

After making sure that the rotation speed is correct, tighten adjusting screw **826**.

Should the spring be completely tightened or the motor operation disturbed, without getting the delivery wanted, it would mean that unit should operate at a higher pressure than the pressure for which it has been designed. Please report to our Technical Department.

Standard bypass use

Standard bypass should not be operated too frequently - even less permanently - since it would result in useless power consumption and material fatigue detrimental to equipment life.

DISASSEMBLY / REASSEMBLY

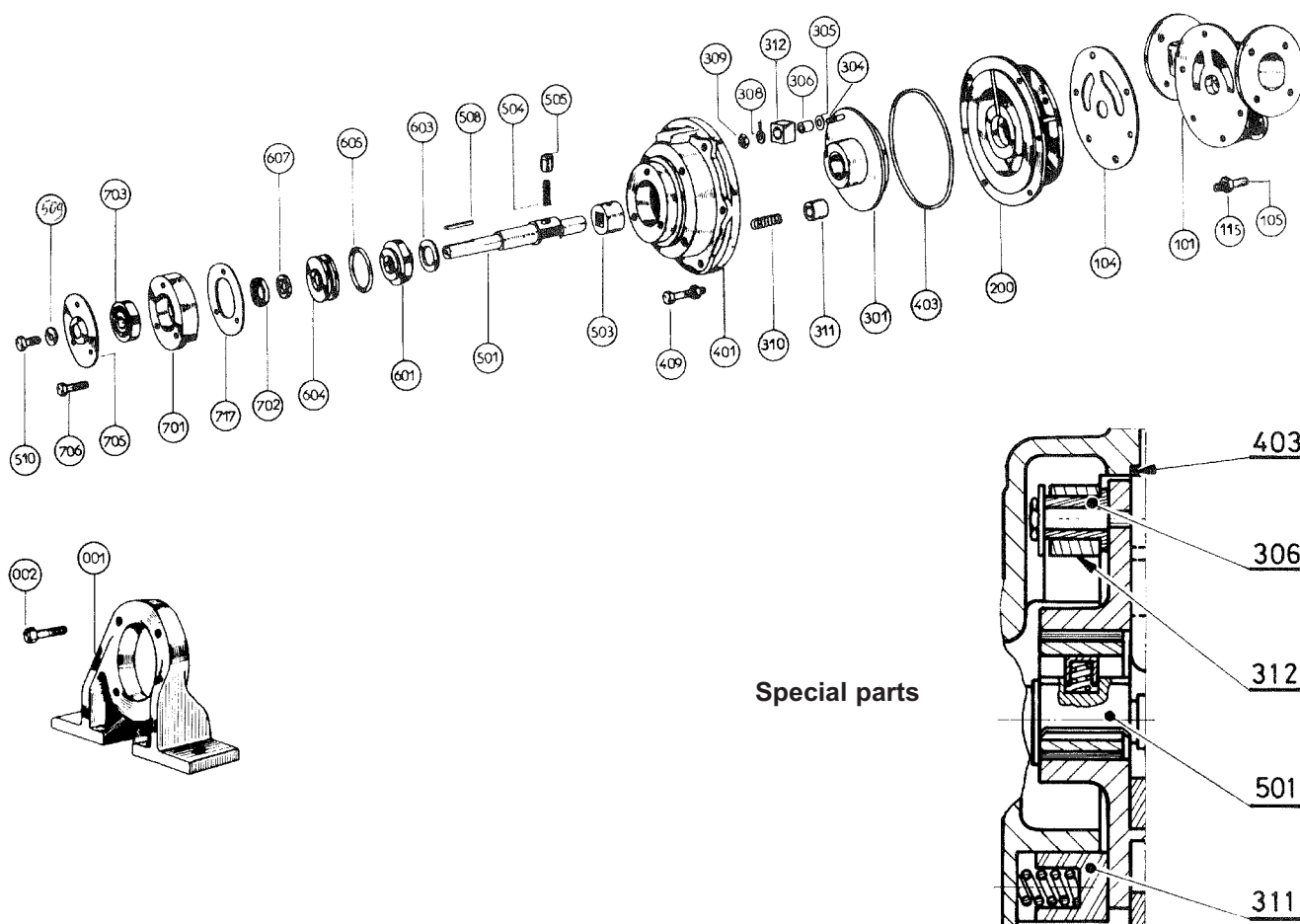

Special parts

Disassembly

To remove head and piston

Remove head bolts **409**.

Remove end-plate **401** by prying it loose.

Using a screwdriver as a lever, back piston **301** away from pump and remove it.

To remove shaft seal and shaft

Refer to § SHAFT SEAL.

Reassembly

Before assembling pump in the reverse order, check the following points :

- spring **504** of piston bearing has not weakened (18 mm mini).
- piston backsprings **310** (22,5 mm mini) have not weakened.

Replace shaft and shaft seal (see § SHAFT SEAL).

Before refitting end-plate, do not forget to refit gasket **403** after making sure it is in good condition.

SHAFT SEAL

BLOCDIR SHAFT SEAL AG H

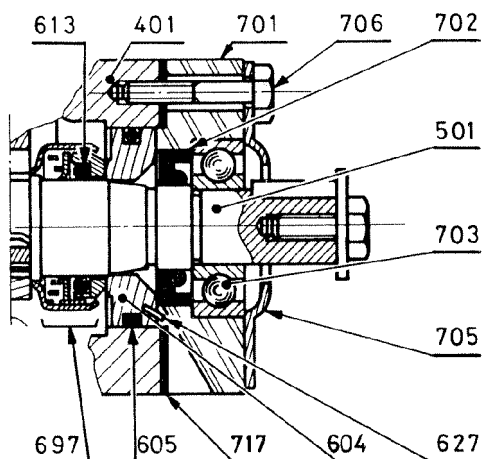

Operation

Shaft **501** rotates monobloc assembly **697** by 2 notches on the shaft that mesh with 2 tabs on the rotating assembly.

Counterpart **604** is held solid with the pump body by seal **605** and stop **627**.

Sealing is ensured :

- 1) On the shaft, by seal of monobloc rotating assembly **697**.
- 2) By the contact surface against monobloc rotating assembly **697** and immobile counterpart **604**.
- 3) In the bore of bottom **401** by seal **605** that is tight against the bottom and fixed counterpart **604**.

Sealing therefore depends on the condition of the contact surfaces and on the seals.

Disassembly

After opening the pump :

- remove the 3 screws **706**, cover **705** and remove cage **701** with the shaft, the bearing and all the parts forming the shaft seal.
- drive the shaft out of the bearing by tapping slightly on the shaft end on the drive side and withdraw assemblies **701**, **703** and **702**, **717**.
- then remove **604**, **605** and monobloc rotating assemblies **697**.

Reassembly

Check condition of seals **605** and **717** and of rotating monobloc **697**.



Check that the contact surfaces of counterpart **604** and monobloc assembly **697** are flat and polished.

- Reassembly all the parts on the shaft in reverse order of disassembly.
- Ensure that the 2 tabs of monobloc rotating assemblies **697** mesh with the notches of shaft **501**.
- Ensure that stop **627** of counterpart **604** enters the leak port of bearing cage **701**.
- Take care not to damage lip seal **702**.
- Replace the shaft, bearing and shaft seal assembly on the pump, taking care to place the leak discharge orifice at the bottom and then fit cover **705** and the 3 screws **706**.

STORAGE

If necessary, refer to § DISASSEMBLY / REASSEMBLY for pump disassembly.

Short duration (≤ 1 month)

 WARNING	IF PUMPING HAZARDOUS OR TOXIC FLUIDS, THE SYSTEM MUST BE FLUSHED PRIOR TO PERFORMING ANY SERVICE OPERATION.
	
Toxic or hazardous fluids can cause serious injury.	

MOUVEX pumps and motor-driven pumps are well lubricated when delivered to protect the internal parts during brief storage in a building where :

- the temperature remains between 10°C and 50°C.
- the relative humidity does not exceed 60%.
- exposure to vibration is limited.
- pump is stored in an area sheltered from bad weather and sun.

Long duration (> 1 month)

The recommendations from the manufacturer should be followed if the pump is stored with its gear motor.

Pump ports should be filled with a non-corrosive liquid that it compatible with the pump components in order to prevent corrosion.

Unpainted external surfaces of the pump (e.g. shafts, couplings, etc.) should be covered in some form of anti-corrosion protection.

The bearing should be well greased. If the pump is to be stored for more than the life of the grease, this one should be replaced in time to prevent an excessive degradation of its qualities.

The best storage conditions are inside a building that meets the conditions set out above.

If inside storage is not possible, the materials should be covered to prevent direct exposure to sun and bad weather. This protection should also prevent condensation.

The pump should be turned a few revolutions manually every two months.

Restarting

Follow the standard start-up procedure for the pump/motor-driven pump, as well as the instructions below.

Turn the pump by hand to make sure the parts move freely.

Replace the grease used to lubricate the bearing.

If the pump has a safety bypass, remove it and inspect the parts and make sure they move freely (see § BYPASS for removal instructions).

SCRAPPING

The pump must be scrapped in compliance with the regulations in force.

During this operation, particular care must be paid to the drainage stages of the pump.