



INSTRUCTIONS 1401-X00 e

Section	1401
Effective	June 2023
Replaces	February 2023

Original instructions



B200 Flow Control SCREW COMPRESSORS

12R/10L PS



12R/10L PF



12R/10L HY



**INSTALLATION
OPERATION
MAINTENANCE
SAFETY
STORAGE**

EC CERTIFICATE OF CONFORMITY :

The EC Certificate of Conformity (paper version) is systematically attached to the equipment when shipped.

WARRANTY :

B200 Flow Control compressors are covered 36 months by warranty within the limits mentioned in our General Sales Conditions. In case of a use other than that mentioned in the Instructions manual, and without preliminary agreement of MOUVEX, warranty will be canceled.

Warranty extension : See § WARRANTY.



Z.I. La Plaine des Isles - F 89000 AUXERRE - FRANCE
Tel. : +33 (0)3.86.49.86.30 - Fax : +33 (0)3.86.49.87.17
contact.mouvex@psgdover.com - www.mouvex.com

Your distributor :

MOUVEX TRUCK SCREW COMPRESSOR

SAFETY, STORAGE, INSTALLATION, OPERATION AND MAINTENANCE INSTRUCTIONS

MODEL : B200 Flow Control

Definition of safety symbols



This is a SAFETY ALERT SYMBOL.

When you see this symbol on the product, or in the manual, look for one of the following signal words and be alert to the potential for personal injury, death or major property damage.



Warns of hazards that **WILL** cause serious personal injury, death or major property damage.



Warns of hazards that **CAN** cause serious personal injury, death or major property damage.



Warns of hazards that **CAN** cause personal injury or property damage.

NOTICE

Indicates special instructions which are very important and must be followed.

REMARKS :

MOUVEX truck screw-type compressors **MUST** be installed in systems designed by qualified personnel. The installation **MUST** be in compliance with local standards, national regulations and rules of safety.

This manual is designed to permit installation and commissioning of MOUVEX truck screw-type compressors and MUST accompany the compressor.

Maintenance of MOUVEX screw-type compressors must ONLY be carried out by qualified technicians. This maintenance must meet local and national standards as well as all safety regulations. Read this manual, including all instructions and warnings, in full BEFORE any use of MOUVEX compressors.

Reading and the removal of the labels on the MOUVEX compressor apply to approval.

TABLE OF CONTENTS

Page













1. OVERALL DIMENSIONS	4
2. GENERAL DATA	7
2.1 Principle of operation	7
2.2 Technical characteristics	7
2.3 Operating ranges	8
3. INSTALLATION	10
3.1 B200 PF with truck power take-off	10
3.2 B200 PS with drive shaft	13
3.3 B200 HY with hydraulic motor	14
3.4 Piping	15
4. USE OF COMPRESSOR	18
4.1 Lubricant recommendations	18
4.2 Filling of lubricant	18
4.3 Operation	18
5. MAINTENANCE	19
5.1 Maintenance schedules	19
5.2 Compressor oil change	19
5.3 Inlet shaft replacement	20
6. TROUBLESHOOTING	21
7. WARRANTY	22
7.1 Warranty claims	22
7.2 24-months warranty extension	22
8. STORAGE CONDITIONS	22
8.1 Compressor	22
8.2 BSC2 oil	22
9. SCRAPPING	22
10. COMPRESSORS FORM INFORMATION	23

ADDITIONAL DOCUMENTATION

The table below gives the list of instructions in addition to this central instruction :

B200 application	Spare parts list
Torque limiter	NT 1401-AB00
Air cooler	NT 1401-AD00
12R/10L	PL 1401-X01

SAFETY DATA

 <p>WARNING</p>		<p>IT IS IMPERATIVE TO APPLY THE TRUCK PARKING BRAKE AND TO BLOCK THE WHEELS BEFORE ANY INTERVENTION DUE TO RISKS OF SERIOUS BODILY INJURIES OR PROPERTY DAMAGE.</p>
<p>Hazardous machinery can cause severe personal injury or property damage.</p>		
 <p>WARNING</p>		<p>COMPRESSING GASES INTO A VESSEL CONTAINING FLAMMABLE OR EXPLOSIVE GASES OR COMPRESSING FLAMMABLE OR EXPLOSIVE GASES, CAN CAUSE PROPERTY DAMAGE, PERSONAL INJURY OR DEATH.</p>
<p>Hazardous fluids can cause fire, serious personal injury or property damage.</p>		
 <p>WARNING</p>		<p>FAILURE TO INSTALL ADEQUATELY SIZED PRESSURE RELIEF VALVE(S) CAN CAUSE PROPERTY DAMAGE, PERSONAL INJURY OR DEATH.</p>
<p>Hazardous pressure can cause personal injury or property damage.</p>		
 <p>CAUTION</p>		<p>COMPRESSOR, PIPING AND ACCESSORIES WILL BECOME HOT DURING OPERATION AND CAN CAUSE SERIOUS PERSONAL INJURY.</p>
<p>Extreme heat can cause injury or property damage.</p>		
 <p>WARNING</p>		<p>CONTENTS OF THE COMPRESSOR, TANK, PIPING, AND FILTERS COULD BE HAZARDOUS TO HEALTH. TAKE ALL NECESSARY PRECAUTIONS WHEN PERFORMING COMPRESSOR SERVICE OR MAINTENANCE.</p>
<p>Hazardous or toxic fluids can cause serious injury.</p>		
 <p>WARNING</p>		<p>THE NOISE EMITTED BY WORKING MOVEX SCREW COMPRESSOR CAN BE HIGHER THAN 80 DBA. THE END USERS MUST USE, WHEN NECESSARY THE APPROPRIATE EAR PROTECTIONS. FAILURE TO WEAR HEAR PROTECTIONS IN AREAS WHERE THE NOISE IS HIGHER THAN 80 DBA CAN LEAD TO PERMANENT BODY DAMAGE.</p>
<p>A loud noise can cause permanent body damage.</p>		

SAFETY CHECK LIST

1. Before operating the compressor, ensure the vessel to which the compressor is connected is certified to withstand the pressure and /or vacuum produced.
2. Verify adequately sized relief valves have been fitted to protect the vessel. Do not use solvents or inflammable products for cleaning the pipelines and the accessories.
3. Gas/air mixtures which are potentially volatile/explosive must not be introduced or allowed to be introduced into the compressor.
4. All pressure vessel and piping connected to the compressor must be isolated and in a safe operating condition.
5. Operators should wear ear protection when operating truck mounted compressors.
6. There are components within the compressor of sufficient weight to cause injury if mishandled. Use proper lifting devices as necessary.
7. Where necessary, this equipment should be grounded to control static electricity.
8. The temperature of the air leaving the compressor is elevated above ambient due to air compression. Check that the elevated temperatures do not adversely affect the product and any material used in design of the system. Attach clearly marked warning signs to warn of potentially hot surfaces on the compressor, piping and accessories which will burn if touched.
9. Mounting of the compressor must be correctly engineered and the compressor must be properly secured. See § INSTALLATION.

NOTICE :

MOVEX COMPRESSORS ARE DESIGNED TO PRODUCE COMPRESSED AIR. NOT TO PUMP LIQUIDS, LIQUEFIED GASSES OR POWDERS THOUGH THE COMPRESSOR. TO DO SO WOULD VOID THE WARRANTY.

LIFTING POINTS :

The compressor can be picked up from underneath to be transported.

Discharge flanges threads can be used to install a lifting lug in order to transport the compressor.

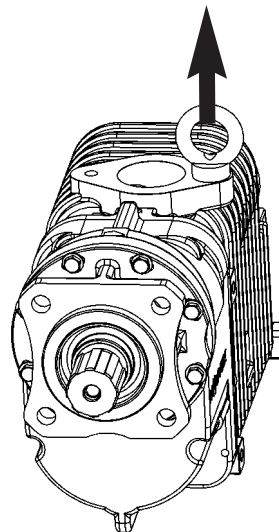

1. OVERALL DIMENSIONS

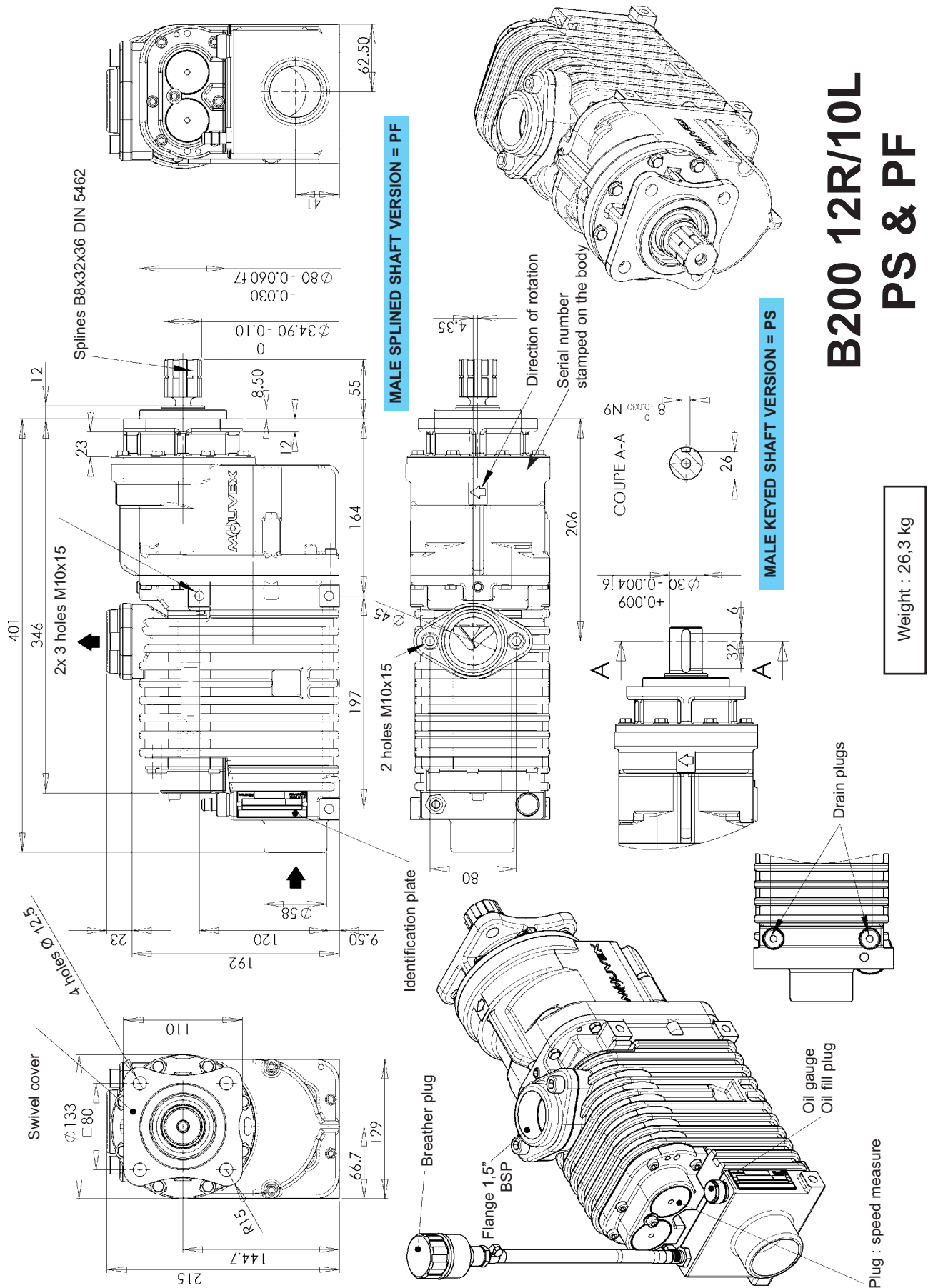

1. OVERALL DIMENSIONS (continued)

FEMALE SPLINED SHAFT VERSION
FOR HYDRAULIC DRIVE = HY

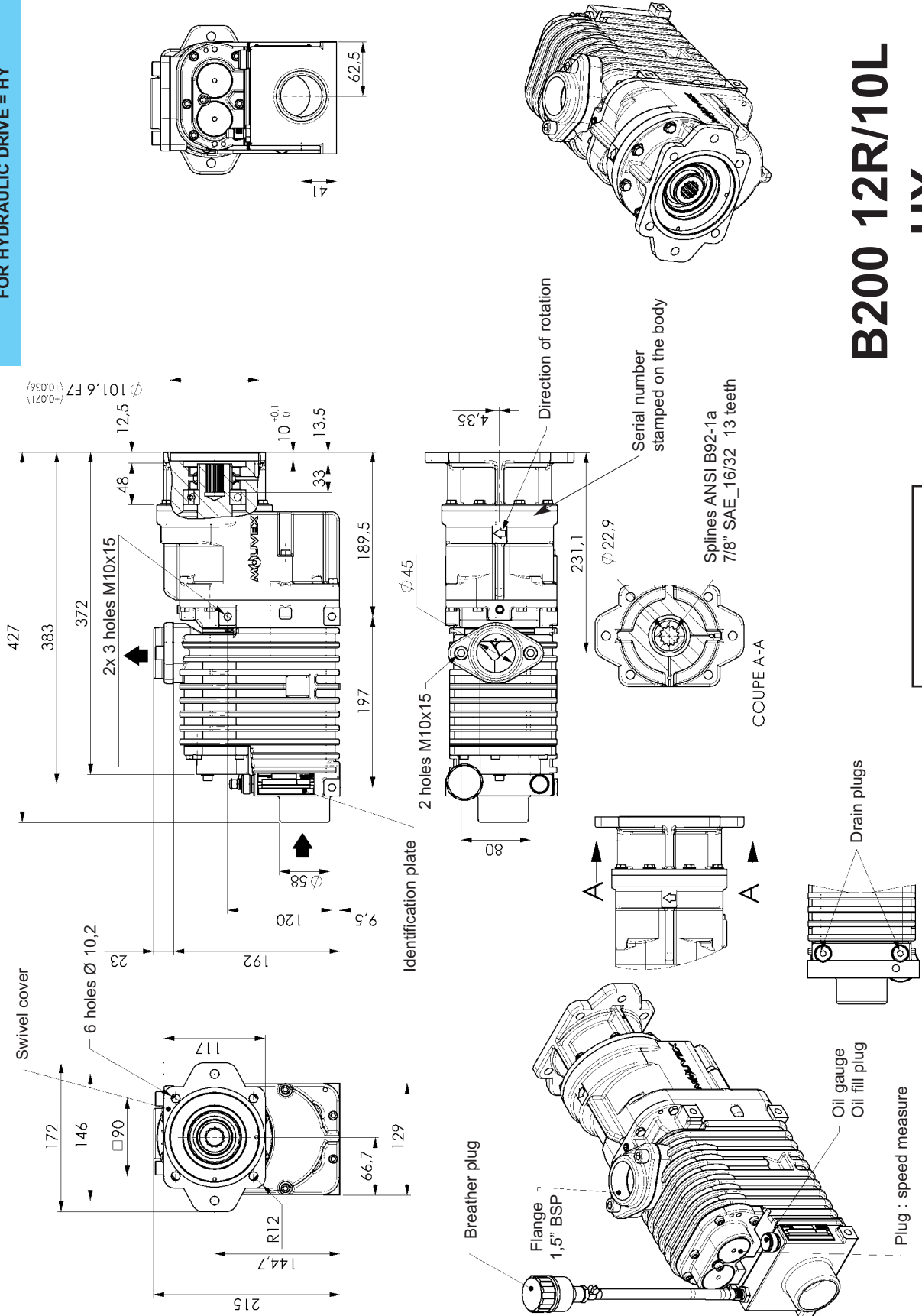

B200 12R/10L HY

Weight : 26,8 kg

1. OVERALL DIMENSIONS (continued)

CHECK AND RELIEF VALVE

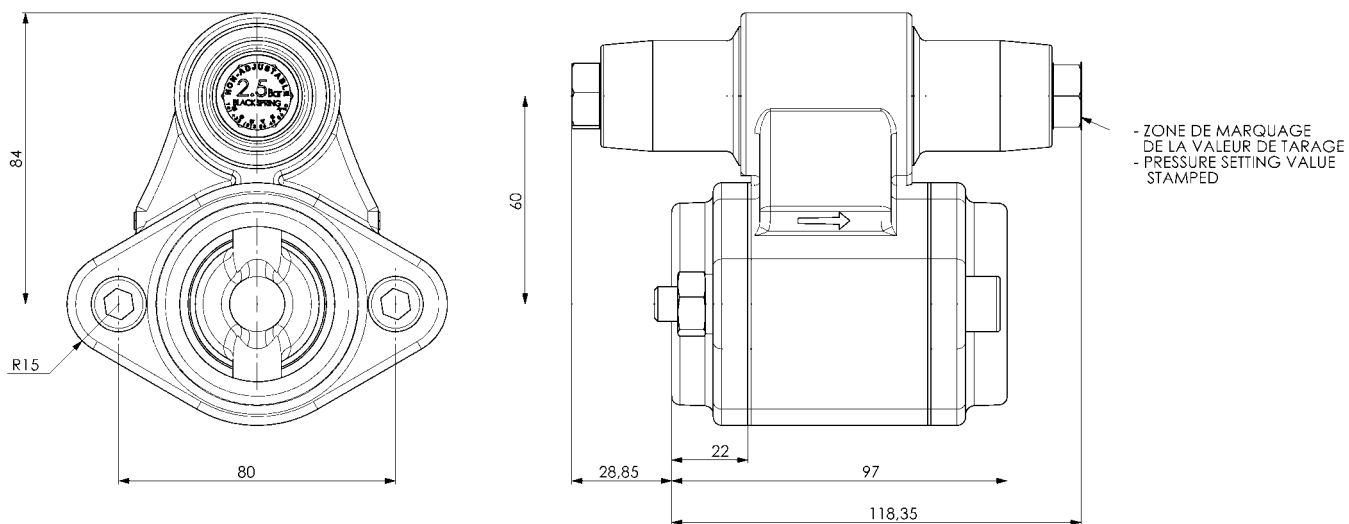

- DEBIT MAXIMUM / MAXIMUM FLOW RATE : 200 m³/hr
- PERTE DE CHARGE DU CLAPET AU DEBIT MAXIMUM / CHECK VALVE PRESSURE DROP AT MAXIMUM FLOW : < 0.1 BAR
- REGLAGES DU TARAGE / RELIEF VALVE SETTINGS : 2.0/2.3/2.5 BAR ± 7%
- PERTE DE CHARGE MAXIMALE AU TRAVERS DES SOUPAPES / MAXIMUM RELIEF VALVES PRESSURE DROP : 0.2 BAR

2. GENERAL DATA

2.1 Principle of operation

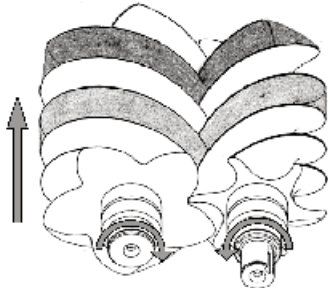

The male screw and the female screw mesh and rotate in opposite directions inside the casing fitted with inlet and discharge ports.

Rotation generates a volume increase on the inner face between threads and grooves, which corresponds to inlet, and a volume reduction on the upper face, which corresponds to compression.

On the discharge port side, a set of gears synchronizes the male screw and the female screw. Thus, the screws are not in contact. The discharged air does not enter in contact with any friction part and remains clean and free from particles.

On the drive shaft side, the female screw or the male screw according to the inlet shaft direction rotation is driven by a set of step-up gears.

Oil circulates, lubricating gears and ball bearings.

On the non-drive end side, the ball bearings are lubricated permanently with grease.

Sealing is provided between lubricated parts and the compression stage by means of labyrinth seals.

These seals do not enter in contact with the shaft and are not subject to wear.

Thanks to their rugged design, B200 compressors have a long service life.

B200 compressors need very limited maintenance, which reduce vehicle downtime.

B200 versions 12R (1200 rpm) or 10L (1000 rpm) were defined so as to drive it directly through on the PTO or with a drive shaft. Thanks to this system, the installation is lighter and saves space on the side of the vehicle for other accessories.

2.2 Technical characteristics

The operating characteristics indicate the requirements to be met, on the B200 compressors, in order for the equipment to benefit from the associated warranty.

The operating characteristics for the B200 are given in the indicative operation conditions : ambient temperature and air inlet temperature 20°C, atmospheric pressure : 1013 mbars.

Speed :

B200	1	2	3	4
12R (rpm)	840	960	1080	1200
10L (rpm)	700	800	900	1000
Maximum discharge pressure (bar)	2	2	2,5	2,5
Maximum inlet temperature (°C)	40	40	40	40

Characteristics of compressor :

Suction : 1 atm , 20°C Flow measurement : ISO 5167-2

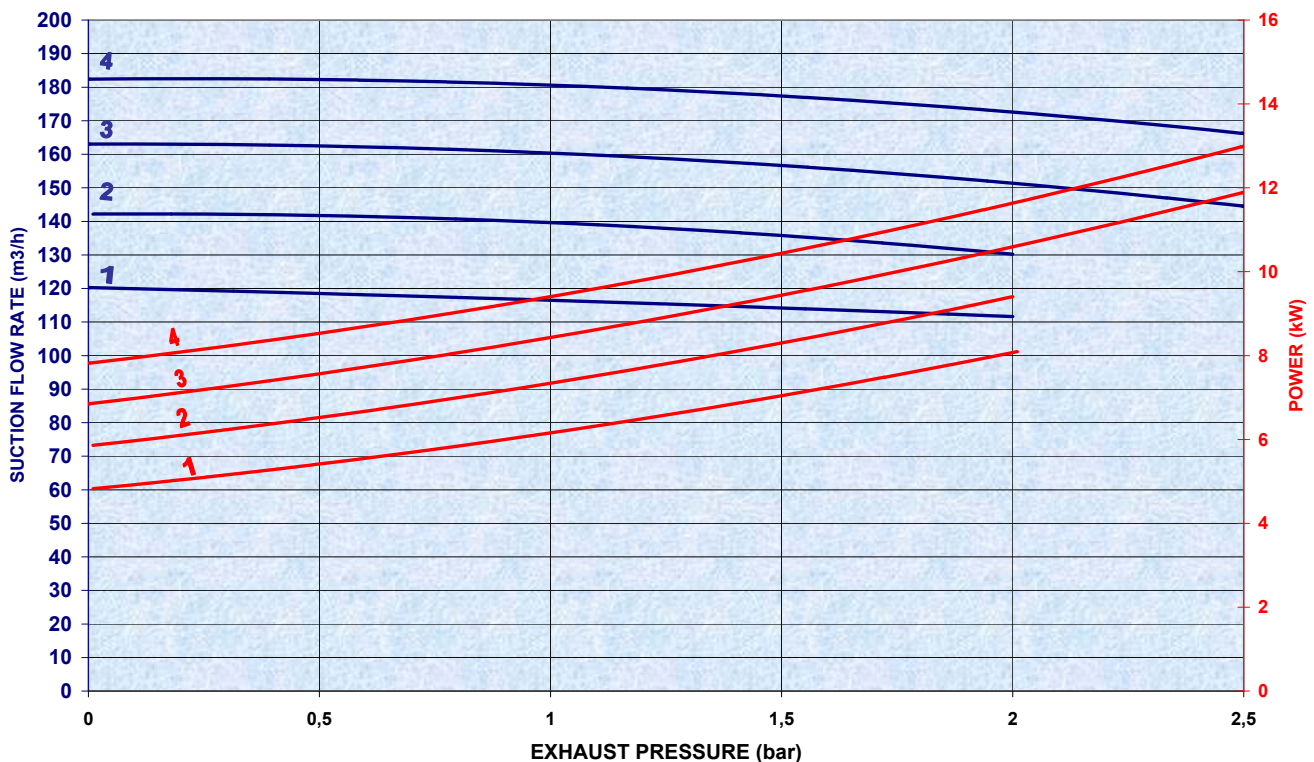

2. GENERAL DATA (continued)

2.3 Operating ranges

The operating ranges specified in the § TECHNICAL CHARACTERISTICS give the conditions that must be respected on mounting and packaging of the B200 compressors, in order to be able to benefit from the guarantees for these pieces of equipment.

The MOUVEX relief valve is designed in order to release any potential overflow. A speed reduction is therefore needless otherwise to increase the machine temperature.

We recommend to set a single working point corresponding to the maximum speed of the compressor, which allows an optimal cooling. This operating point (otherwise the range) must be absolutely fixed by the Motor management in order to avoid any use outside these limits. See § MOTOR MANAGEMENT.

MAXIMUM ACCEPTABLE DISCHARGE PRESSURE (see § TECHNICAL CHARACTERISTICS)

The Check Relief Valve (CRV) is available with the setting 2 bar, 2,3 bar and 2,5 bar.

It is necessary to select the required value depending on the limits of the tank, the position of the CRV and the value of the pressure losses so that the maximum pressure at the compressor is controlled.

The CRV is assembled and tested by us, its opening pressure at full flow (closed discharge valve) may fluctuate slightly based on the following parameters :

- Dimensional dispersion associated to the tolerances of components.
- When the CRV is cold, it generates a greater pressure of 0,15 bar.
- The opening of valves naturally generates pressure losses, pressure at full flow is therefore increased.

As a result, a hot CRV can reach in full flow a pressure greater than its value of calibration in the range of 0,35 bar maximum. A 2,5 bar CRV is therefore likely to reach 2,85 bar in full flow.

The operating mode with a closed valve (no unloading flow) is therefore allowed only intermittently (less than 1 min), whatever the type of relief valve used. In this case, the full flow goes out and generates an unnecessary pressure rise. The result is an overheating of the compressor and potentially irreversible damages not covered by our warranty.

B200 Flow Control 2,0 bar : Débit et pression acoustique/Flow rate and acoustic pressure

Aspiration Compresseur/Compressor suction 1 atm 20°C

Mesure débit selon/ Flow measurement : ISO 5162-2

Mesure bruit/ Noise measurement : 1m de la CRV; 1,5 m du compresseur/ 1 m from the CRV; 1,5 m from the compressor

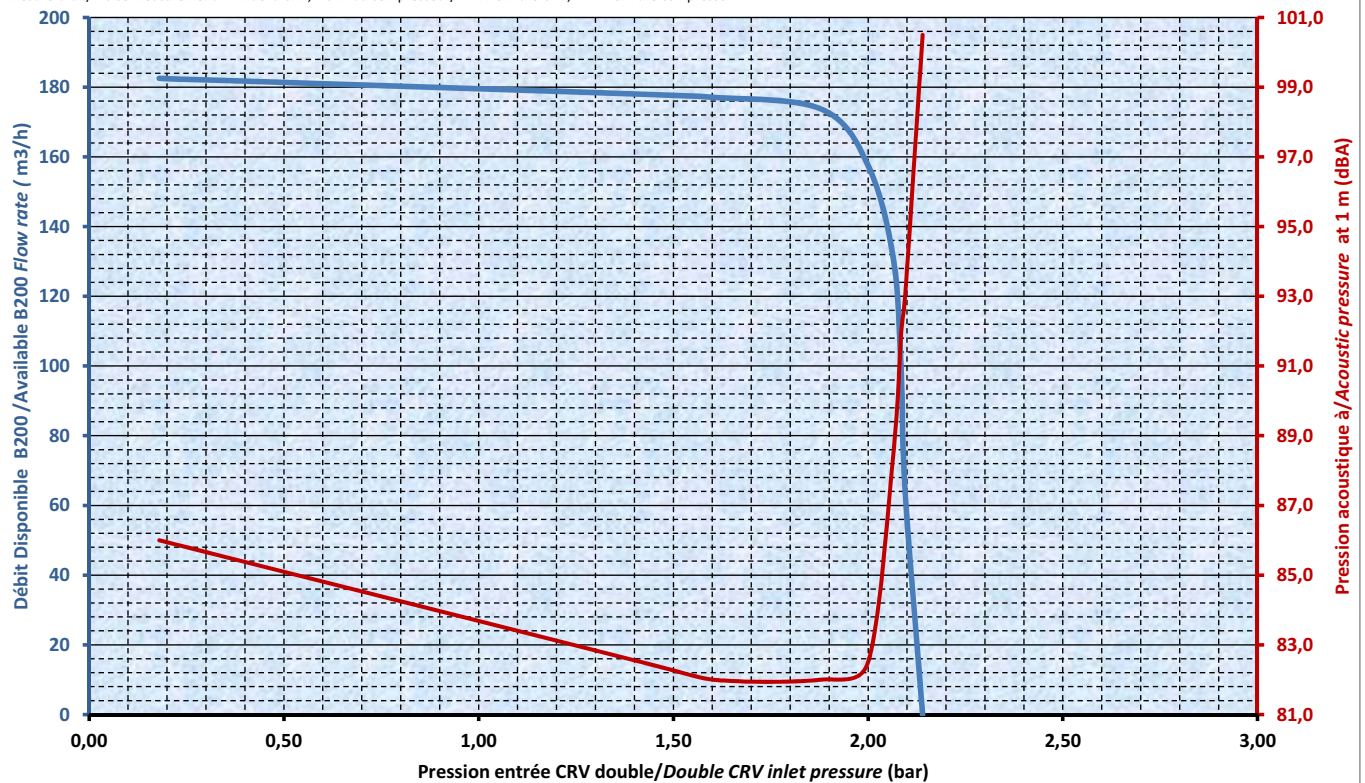

2. GENERAL DATA (continued)

B200 Flow Control 2,3 bar : Débit et pression acoustique/Flow rate and acoustic pressure

Aspiration Compresseur/Compressor suction 1 atm 20°C

Mesure débit selon/ Flow measurement : ISO 5162-2

Mesure bruit/ Noise measurement : 1m de la CRV; 1,5 m du compresseur/ 1 m from the CRV; 1,5 m from the compressor

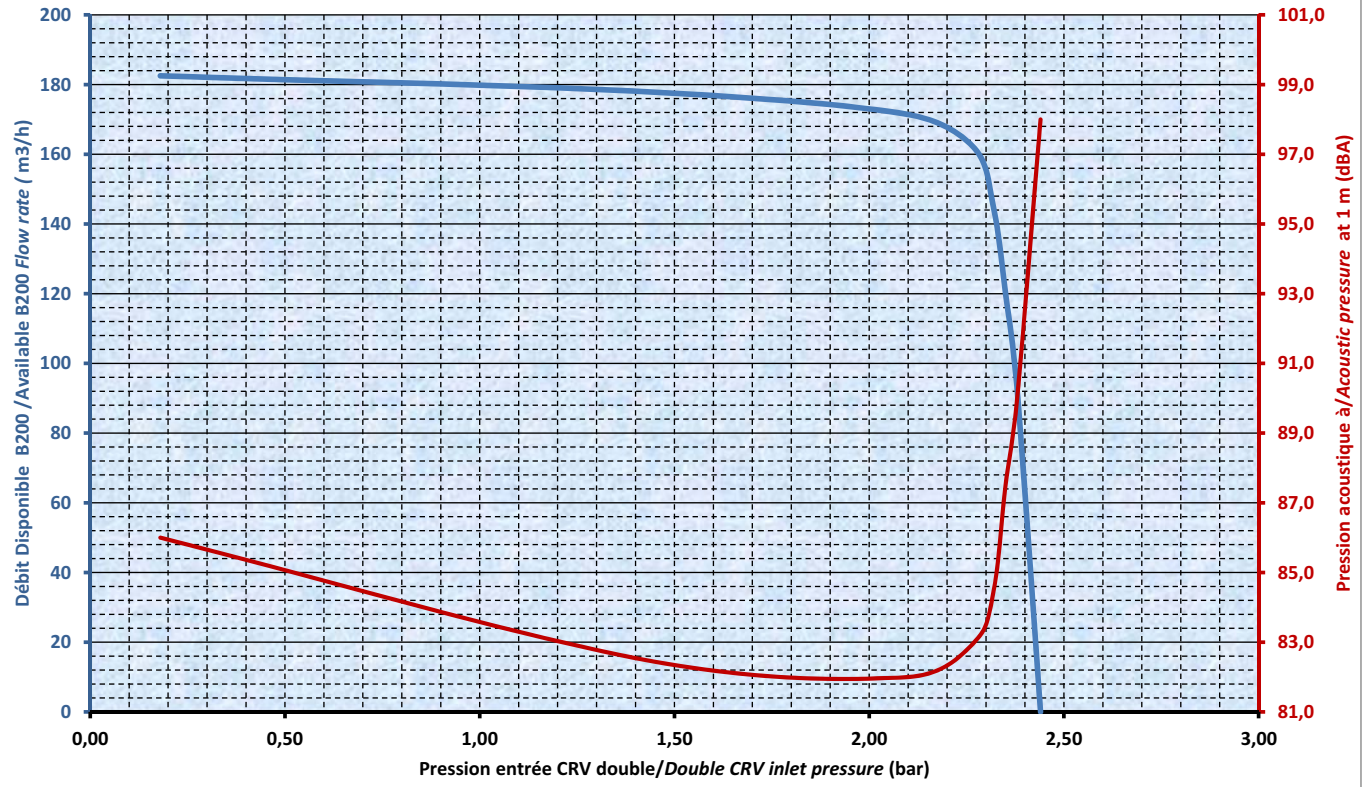

B200 Flow Control 2,5 bar : Débit et pression acoustique/Flow rate and acoustic pressure

Aspiration Compresseur/Compressor suction 1 atm 20°C

Mesure débit selon/ Flow measurement : ISO 5162-2

Mesure bruit/ Noise measurement : 1m de la CRV; 1,5 m du compresseur/ 1 m from the CRV; 1,5 m from the compressor

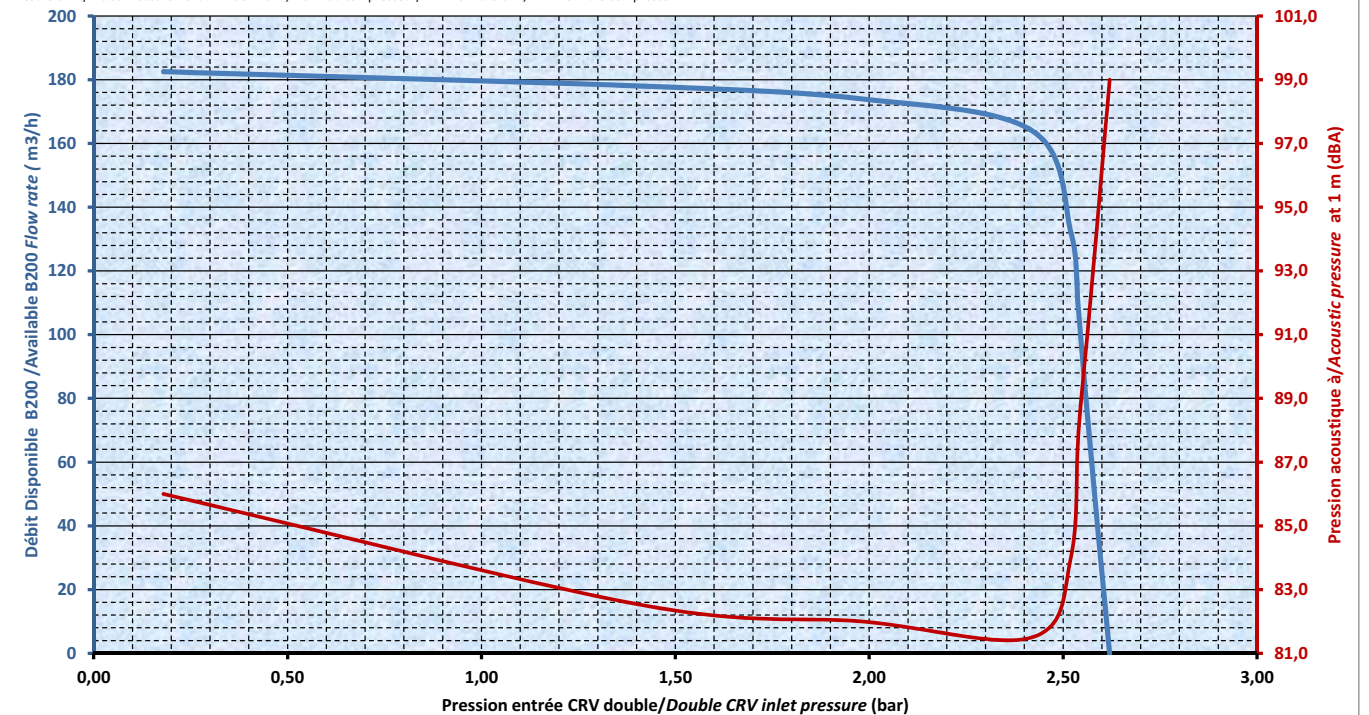

3. INSTALLATION

3.1 B200 PF with truck power take-off

3.1.1 Installation of the compressor

The B200 PF compressors have a male splined shaft DIN 5462 / ISO 14 and a mounting flange ISO 7653-D that allows them to be installed directly on declutchable power take-offs.



Power Take Off specifications :

- **Must allow a gravity torque of 50 Nm and be able to accept a working torque of 124 Nm along all the unloading duration.**

Tank builders :

- **MERCEDES :**
 - Original model in aluminium type NA 131 2C compatible, in compliance with the dispensation delivered by MERCEDES.
 - Every other model in cast iron or aluminium in compliance with the specifications above.
- **DAF / IVECO / MAN / RVI / SCANIA :**
 - Every original or not original model, whatever the material : cast iron or aluminium, in compliance with the specifications above.
- **VOLVO :**
 - Original model in aluminium type PTR DM compatible for the range FH/FM in compliance with the dispensation delivered by VOLVO.
 - Every other model in cast iron or aluminium in compliance with the specifications above.

Not allowed :

- **Power take off with double outlet**

Installation and operating conditions :

- **The use of the discharge flexible supplied by MOUVEX, fitted in accordance with the B200 Instructions.**
- **The use of the fixation kit supplied by MOUVEX, fitted in accordance with the B200 Instructions.**
- **No extra bracket required to fix the B200.**
- **B200 must be fitted, operated and serviced in a proper installation in accordance with the B200 Instructions, with the PTO Manufacturer and Truck Builder Instructions.**

Installation is done with screws or studs, minimum grade 8.8.

The B200 PF is provided with a mounting kit that includes a metallic PTO seal, and 4 specific nuts and washers that it is essential to use.

If this is possible, tighten the 4 nuts to 37 Nm for all the PTOs. Don't put any grease on the studs.

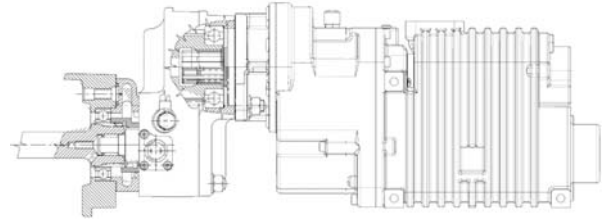

The compressor can be mounted in slightly tilted position, but should remain within the angular values defined on the figures below.

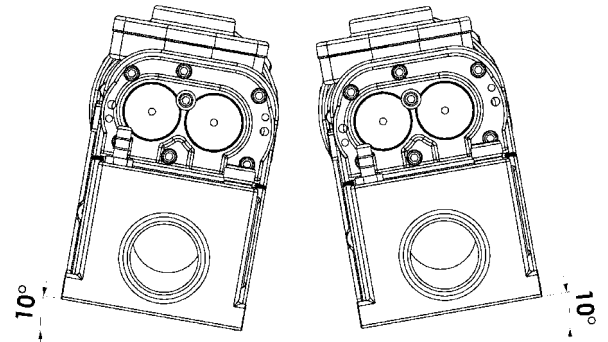

The tapped holes in step-up casing **1086** and the openings on cover **3** can be used to obtain a suitable inclination, whatever the inclination of the PTO flange.

To obtain only a slight inclination of the PTO flange, it is possible to bring the compressor back in a horizontal position, taking care to proceed as follows :

- Loosen the 8 screws **1095** without removing them.
- Put the compressor in the desired position.
- Tighten the screws **1095**.

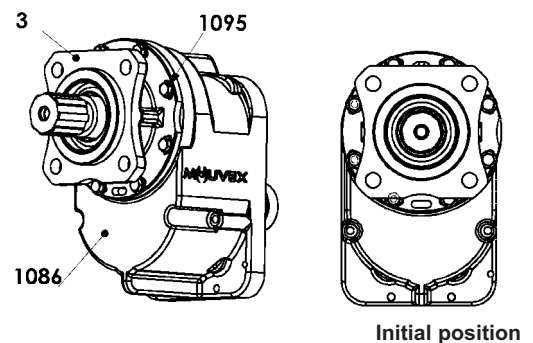

3. INSTALLATION (continued)

To obtain a strong inclination of the PTO flange, it is possible to bring the inclination of the compressor to an angle lower than 10°, taking care to proceed as follows :

- Loosen and remove the 8 screws **1095**.
- Remove the screws **1095** and the cover **3**.

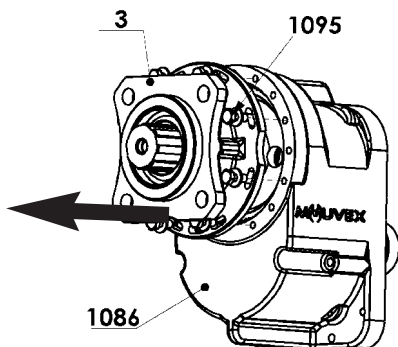

- Turn the cover **3** in order to offset the ports and position them over the next set of tapped holes on the casing **1086**.

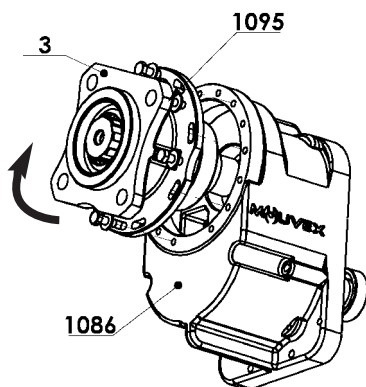

- Engage the cover **3** in the desired position.
- Tighten the 8 screws **1095**.

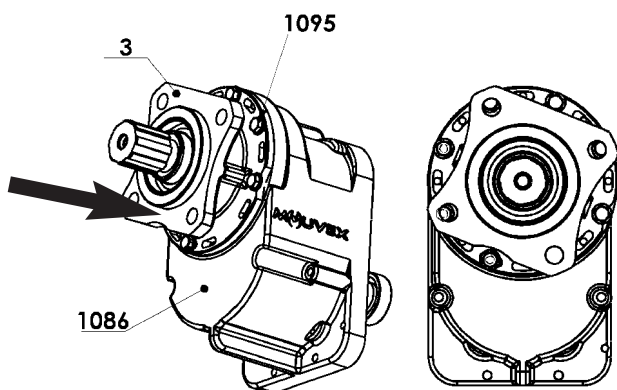

Final position



Screws **1095** must be :

- equipped with their lock washers, notches on the side of the screw head,
- sealed with Loctite® * thread locking 243 or equivalent,
- tightened at 13 Nm.

3.1.2 Adjustment of the drive speed

For compressors that are secured by flange on the power take-off or on the hydraulic motor, the compressor drive speed can only be measured indirectly on the male or female screw of the compressor, using a tachometer with a maximum capacity of 20 000 rpm.

A contact tachometer of the Multimetrix® RPM82 type is perfectly well suited for measuring the speed on the screws of the B200 compressor.

Since the male and female screws do not rotate at the same speed, refer to the tables in the paragraphs below in order to establish the correspondence between the drive shaft speeds and the speed of the screw on which the measurement is performed :

- Measure on the male screw :Table 1
- Measure on the female screw :Table 2

To access the rotating screws, unscrew screw **38** and remove plugs **20**.

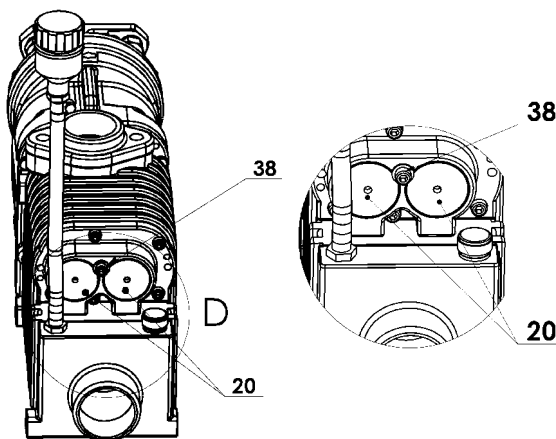

In order to check that the compressor is rotating in the right direction, check that the male and female screws rotate in the directions specified on the drawing below, whatever the drive variant (B200 12R and B200 10L) :

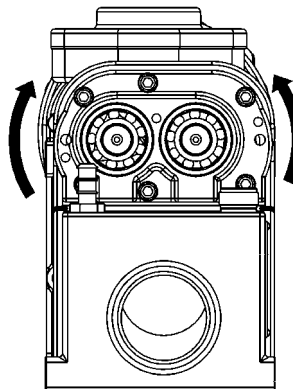

The B200 compressors fitted with a check valve can withstand a short operating time (less than 30 seconds) in the opposite direction, as required for checking the rotation direction.

NOTICE :

Prolonged operation in a direction different from the direction indicated on the drawing below may cause serious damage to the compressor and would cancel the warranty.

* Loctite® is a registered trademark.

3. INSTALLATION (continued)

Reversing the rotation direction requires that the compressor be returned to the factory.

Speed pick-up on the male screw :

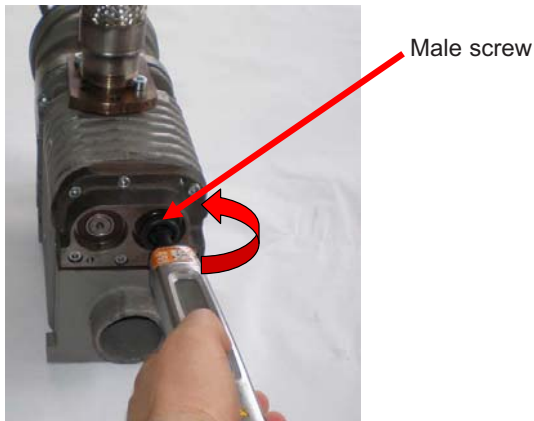

Table 1

Male screw and drive shaft speed correspondence

	Inlet shaft speed (rpm)	Male screw speed (rpm)
B200 12R	850	13 910
	1 000	16 365
	1 100	18 000
	1 200	19 640
B200 10L	700	13 750
	800	15 710
	900	17 675
	1 000	19 640

Speed pick-up on the female screw :

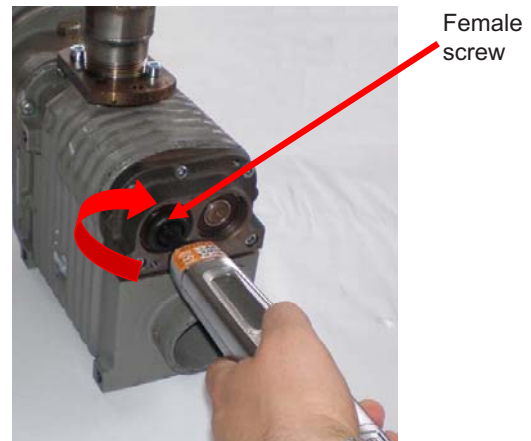

Table 2

Female screw and drive shaft speed correspondence

	Inlet shaft speed (rpm)	Female screw speed (rpm)
B200 12R	850	11 600
	1 000	13 640
	1 100	15 000
	1 200	16 365
B200 10L	700	11 450
	800	13 095
	900	14 730
	1 000	16 365

3.1.3 Motor management

The Motor management is mandatory, it has to ensure 2 missions :

- **To secure the operating range :** The operating point (otherwise the range) must be set to avoid any operation outside the range. If a risk remains (need to switch in complement a gear box button) an information sticker shall be affixed in the cabin.
- **To ensure a smooth start-up :** The start-up of the PTO must be carried out gradually without generating a peak of torque to avoid damaging the Compressor. The maximum peak torque that can be supported by the compressor is 600 N.m. This is particularly sensitive for the B200 PF which is equipped with a shaft groove.

The operating speed of the compressor must be reached in more than 0.25 s.

It is in particular to ensure that the parameter "TRANSMISSION INPUT SPEED" (N° 10.520 on MERCEDES) is set to a value less than 10. Otherwise, that will generate in a medium term a breakage of the B200 shaft.

3. INSTALLATION (continued)

3.2 B200 PS with drive shaft

3.2.1 Installation of the compressor

- Mount the compressor in a position where it is protected from dirt, debris and road spray. The mounting location should allow for regular inspection, cleaning and maintenance.
- The B200 compressor mounting points are located on the sides of the body.

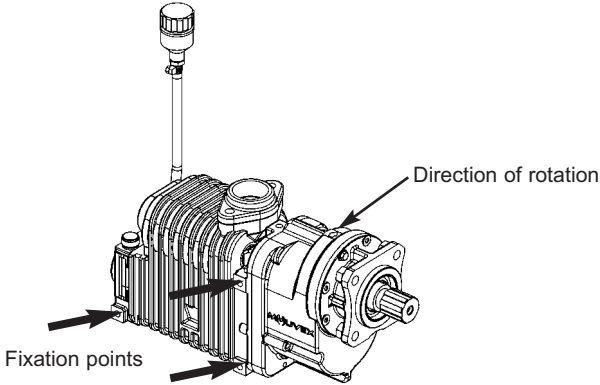

Installation is performed by means of screws, minimum grade 8.8.

3.2.2 Recommended drive conditions

The drive shaft must be sized so as to be able to accept the loads above and also the starting torque.

Operating torque at full speed

B200	Pressure		
	1,5 bar	2,0 bar	2,5 bar
Torque 12R (Nm)	83	93	103
Torque 10L (Nm)	100	111	124

It is the responsibility of the installer to check that his design protects the transmission if the compressor blocks.

Compressors B200 12R PS and B200 10L PS must be protected by a 400 Nm torque limiter, in order to protect the truck's transmission if the compressor is jammed. MOUVEX may not be held liable for any damages resulting from such jamming if the torque limiter has not been installed.

Comply strictly with the following instructions :

	WARNING
	DRIVES SHAFTS MUST BE GUARDED IF EXPOSED. OPERATION WITHOUT GUARDS CAN CAUSE SERIOUS PERSONAL INJURY, MAJOR PROPERTY DAMAGE OR DEATH.
Do not operate without guard in place.	

- The drive shaft slides perfectly well during rotation. Square slip joints are forbidden.
- Drive shaft length should be as short as possible and the drive shaft **MUST** be balanced.



The non balancing of the drive shafts can lead to mechanical ruptures that are susceptible of causing important property damage and/or serious injuries.

- The drive shaft and compressor shaft **MUST** be parallel within 1° and have a maximum of 10° compound misalignment. See Table :

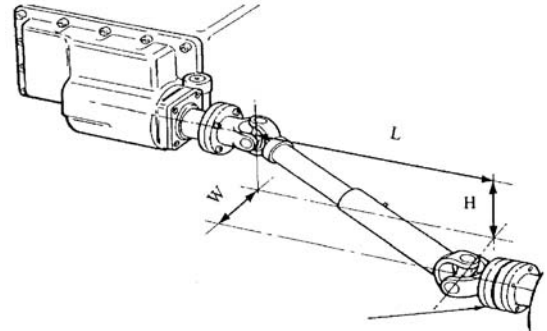

$$A = \frac{\sqrt{H^2 + W^2}}{L}$$

If H = Zero, A = W / L

If W = Zero, A = H / L

A	Universal joint angle	
0,017	1°	VERY GOOD
0,035	2°	
0,052	3°	
0,070	4°	
0,087	5°	GOOD
0,105	6°	
0,125	7°	
0,141	8°	
0,158	9°	LIMIT VALUES
0,176	10°	
0,194	11°	
0,213	12°	
0,231	13°	
0,249	14°	
0,268	15°	

- Universal joints **MUST** be in phase, with the drive shaft slip joint at mid-position. Use an even number of universal joints.
- Make sure that the compressor rotates in the direction of the arrow on the body.

The B200 compressors fitted with a check valve can withstand a short operating time (less than 30 seconds) in the opposite direction, as required for checking the rotation direction.

NOTICE :

Prolonged operation in a direction different from the direction indicated on the drawing below may cause serious damage to the compressor and would cancel the warranty.

3. INSTALLATION (continued)

3.3 B200 HY with hydraulic motor

The B200 HY compressors have a female splined shaft ANSI B92-1a that allows to flange directly on hydraulic motor equipped with a shaft 13T 718 SAE 16/32 and a mounting flange SAE B 2 or 4 holes.

3.3.1 Hydraulic motor assembly

It is possible to change the orientation of the lantern 230, taking care to proceed as follows :

- Loosen and remove the 8 screws 1095.

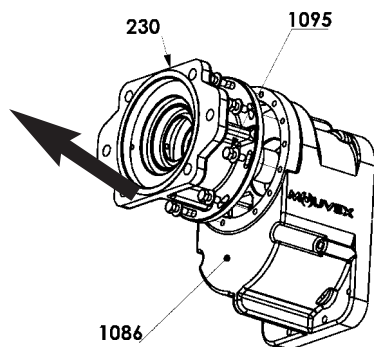

- Rotate the lantern 230 so as to offset the ports and move them over the set of tapped holes on casing 1086 that approach the desired position.

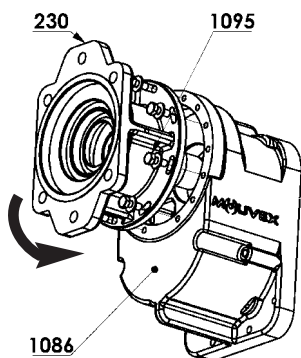

- Make sure that at least one of the 2 collectors is located in the lower part of the lantern 230, otherwise turn the lantern 230 by 180°.
- Engage the lantern 230.
- Tighten the 8 screws 1095.

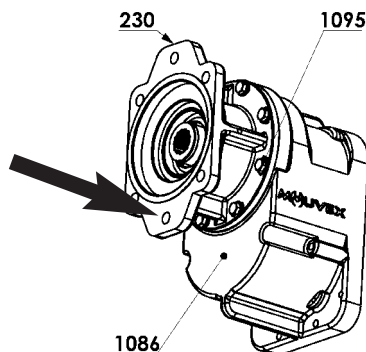

- Install the screwing plug 1204 in the highest collector on the lantern 230.

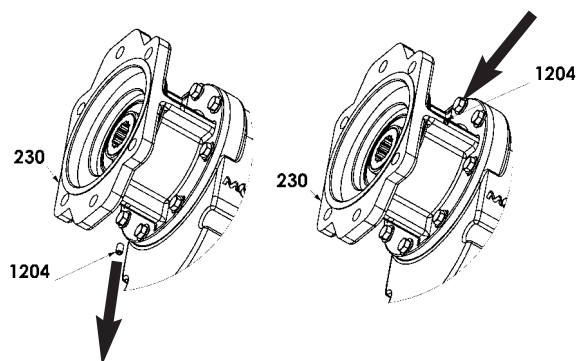

- Check that the rotation direction of the motor and the compressor are correct.
- Lubricate the motor shaft and the female splined shaft 1091 to facilitate subsequent disassembly.



Screws 1095 must be :

- equipped with their lock washers, notches on the side of the screw head,
- sealed with Loctite®* thread locking 243 or equivalent,
- tightened at 13 Nm.

3.3.2 Adjustment of the drive speed

See § ADJUSTMENT OF THE DRIVE SPEED.

* Loctite® is a registered trademark.

3. INSTALLATION (continued)

3.4 Piping

3.4.1 Inlet

The suction side of the compressor MUST be fitted with an adequately sized air filter, which MUST be protected from water, road spray, or other debris. This filter is available from MOUVEX. Use of wrong filter will void warranty. The compressor filter must be connected by means of a hose capable of operating in vacuum and of a sufficient length to absorb the relative movements of the compressor relative to the chassis. The compressor is delivered with an inlet connection kit which is installed as follows :

Composition of the kit :



Item	Description	Quantity
152A	Heat shrinkable sleeve	2
164	Hose (length 2 meters)	1
165-166	Clamp	2
884	Hump	1xØ50 (black) 1xØ57 (grey)

Assembling procedure :

- To cut the hose to the length requested.
- To fold back the end of the wire inside.



- To screw home the humps at the 2 ends.



- Result :



- To pass a heat-shrinkable sleeve on an end and to center it on the end of the hump. To retract gradually by means of a heat gun. Attention not to point the gun towards the hose not covered, risk of perforation.

To proceed in the same way at the other end.



- To check the hose is perfectly clean inside, and to remove the protections caps on the compressor.
- To assemble the unit on the compressor inlet port and to tighten the clamp : cast solid end.

Example :



- To proceed in the same way with the air filter.



- To then suspend the hose while taking care to protect it from any friction and the potentially hot bodies such as muffler.

3. INSTALLATION (continued)

The inlet filter should be positioned to draw in clean, cool air, and should be mounted away from any engine heat and exhaust.

The compressor inlet suction air must be filtered in order to eliminate particles bigger than 5 µm.

The maximum pressure drop at suction must be lower than 75 mbar.

A restriction indicator system must permit changing the suction filter when it creates a pressure drop greater than 75 mbar.

The maximum acceptable temperature at suction as a function of equipment operating conditions is given in the § TECHNICAL CHARACTERISTICS.

3.4.2 Outlet

The flange supplied must be equipped with its gasket, screw tightened at 44 Nm.

Piping MUST be at least as large as the compressor suction and discharge connections.

All the connections located between the compressor and the trailer hose connection point must be absolutely waterproof. For that reason, they must be welded.

The B200 PF compressors directly flanged onto the power take-off must be fitted with the metallic discharge hose delivered with the equipment. This woven stainless steel hose is designed to avoid having any stresses applied on the compressor flange and the rigid pipes of the systems, as induced by the relative movements of the compressor with respect to the chassis.

For the B200 PF, it should cancel the stresses on the flange, as induced by the movement of the compressor, and respect the rules below :

- install a 90° elbow between the flange and the hose.
- support the stainless steel hose correctly at its end part.
- the hose output pins should be mounted in the same horizontal plane. Make sure that the installation allows a compressor displacement of ± 5 cm to be obtained.

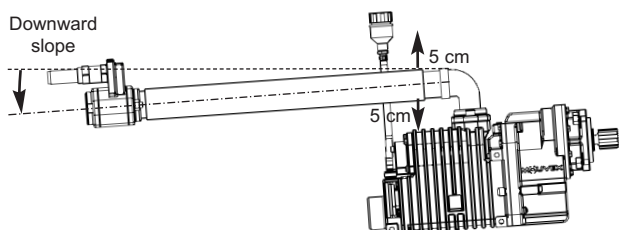

- on the same horizontal plane, if the output pins are not parallel, the bending radius must be as large as possible, and in any case at least equal to 50 cm. Make sure that the installation allows a compressor displacement of ± 5 cm to be obtained.

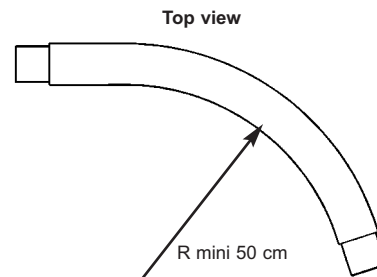

Installation rules : Discharge line

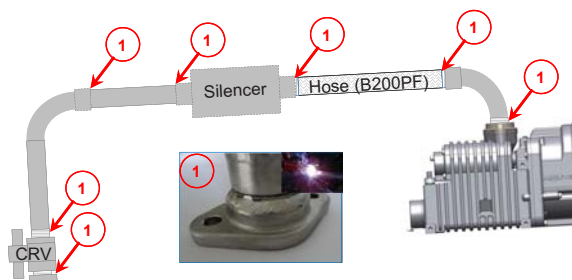

All the connections must be welded and be the object of a waterproof quality control.

During installation, position a pressure gage on the compressor output, so as to measure the operating pressure. The measurement should be done at the discharge flange level and should not exceed 2,5 bar over the allowable operating range of the compressor.

 CAUTION	<p>OPERATING A COMPRESSOR ABOVE ITS MAXIMUM OPERATING PRESSURE CAN CAUSE SUBSTANTIAL PROPERTY DAMAGE OR SERIOUS BODILY INJURIES.</p>
 <p>Extreme heat can cause injury or property damage.</p>	

It is mandatory to protect the compressor with the Check relief valve supplied by MOUVEX. The check valve prevents any air from returning in the compressor when it is no longer in operation.

The safety valve protects the compressor against possible overpressure. The maximum set point of the valve is 2,5 bar. **If there is a drop in pressure between the pressure relief valve and the compressor, reduce the pressure relief valve setting by the value of the pressure drop.** It is the installer responsibility to check that the relief valve is compliant with the compressor performance for the application speed.



The compressor is delivered with a check and relief valve allowing 3 settings capabilities : 2 bar, 2,3 bar or 2,5 bar.

It will have to be selected depending of the installation limits and by making sure the maximum pressure of 2,5 bar of the compressor is never exceeded. Be careful in particular with the pressure drop located between the check relief valve and the compressor especially if an air cooler and a silencer are used.

3. INSTALLATION (continued)

It is forbidden to insert a damping valve in the pipe linking the compressor to the tank hose connector in order to avoid any risk of water entering.

Ensure that ALL components are capable of operation at the maximum system pressure limits and that all vessels are adequately protected by SEPARATE relief valves.

	WARNING
	FAILURE TO INSTALL ADEQUATELY SIZED PRESSURE RELIEF VALVE(S) CAN CAUSE PROPERTY DAMAGE, PERSONAL INJURY OR DEATH.
Hazardous pressure can cause personal injury or property damage.	

3.4.3 Oil breather

Compressor B200 is fitted with an oil breather which is mounted on a hose for easier installation.

In case of the inclination of the compressor, it is essential to position the breather on the highest tapped hole. Invert the positions of the oil gage **399** and the breather assembly, as appropriate.

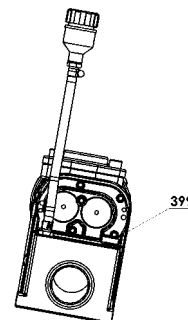

Position the breather plug in a clear area, to avoid any oil condensation.

Do not crush the hose when positioning the breather, so as to allow any oil vapors to be evacuated.

The hose mustn't be shortened,, keeps imperatively its original length.

The breather must be placed above the compressor, preferably with the connecting hose running up towards the breather.

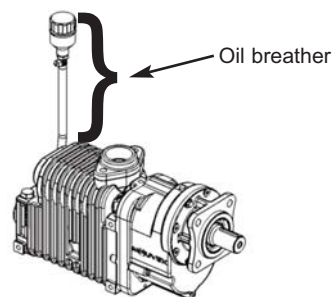

4. USE OF COMPRESSOR

The operator should remain nearby the equipment throughout the use to ensure the proper functioning of the system.

It is imperative to hold the hose in order to avoid whipping during pressurization.



4.1 Lubricant recommendations

The MOUVEX screw compressor operates with MOUVEX BSC2 oil.

It is imperative to change the BSC2 oil every year or 500 operation hours.

The BSC2 oil covers operation from -30°C to +40°C.

4.2 Filling of lubricant



Our compressors are delivered without oil. The use of a compressor with an oil level different from 1,2 l ± 10% can lead to important property damage and serious injuries.

Before starting the system, fill the casing with oil so that the oil level is set between the min and max value of the gauge.

4.3 Operation

- The compressor must be started with the discharge valves open.
- Check the compressor drive shaft rotation direction :
 - B200 12R PS and B200 10L PS : The drive shaft rotation direction must match with the arrow on the body of the compressor.
 - B200 12R PF and B200 10L PF : Refer to § DIRECT INSTALLATION TRUCK POWER TAKE-OFF.

4.3.3 Start-up procedure for manual gear box

- Start the engine and run with standard speed.
- Depress clutch and engage the PTO.
- Release the clutch SLOWLY.
- Set engine speed to give the correct compressor speed.



4.3.4 Shutting down procedure for manual gear box

- Depress the clutch and disengage the PTO.



**PTO
OFF**

- Reduce engine speed to idle.



ALWAYS DISENGAGE THE DRIVE BEFORE SLOWING ENGINE DOWN.

- Release the clutch.



NOTICE :

Prolonged operation in a direction other than the direction of the arrow on the body can cause serious damages to the compressor and would cancel the warranty.

- Avoid if possible stopping or starting the compressor with the tank under pressure.
- At commissioning, check that the combinations of rotation speed and discharge pressure of the compressors are in conformity with those indicated in § TECHNICAL CHARACTERISTICS.



During operation, the temperature of the surface of a compressor and nearby parts can be in the region of 200°C. The compressor and the parts located nearby are thus susceptible of provoking serious burns and property damage. Be careful to not approach elements that are sensitive to heat and affix plates informing users that the compressor is hot, to prevent any risk of burns.

5. MAINTENANCE

5.1 Maintenance schedules

After every cleaning of the truck

Always run the compressor for 15 minutes to remove any water that inadvertently gets into the piping. DO NOT fog or introduce anti-corrosive liquids into the compressor to prevent corrosion : Use of liquids in the compressor will cause failure.

Weekly

1. The compressor should be run for at least 15 minutes to prevent moisture from collecting inside. This will reduce the risk of corrosion damage to the compressor and other equipment in the piping.
2. Inspect and clean air filter. Inspect DAILY if operating in dirty or severe environment. Check the condition of the inlet filter hose for splits and tears. Replace or repair as necessary.
3. Inspect compressor, system piping and components. Clean or repair as necessary.
4. Check power transmission line.
5. Check the air filter restriction indicator. When the indicator turns red, replace the filter cartridge. Before replacing the cartridge with a new one, clean the inside of the filter's body with a clean damp cloth.

Per manufacturer' s recommendations

Lubricate the universal seal (for B200 PS models).

Monthly

1. Check the relief valve(s) for wear and proper settings. Replace or adjust as necessary.
2. Check that the check valve works properly, replace as necessary.
3. Check the oil level and complete if necessary.

Yearly :

1. Check tightness of the 4 mounting nuts on the B200 PTO.

5.2 Compressor oil change

Oil recommendations : See § LUBRICANT RECOMMENDATIONS.

Depending on the inclination of the compressor, remove the lowest drain plug **44**.

Put plug **44** back into place and remove filling plug **399** and fill the compressor with new oil, as recommended in § LUBRICANT RECOMMENDATIONS.

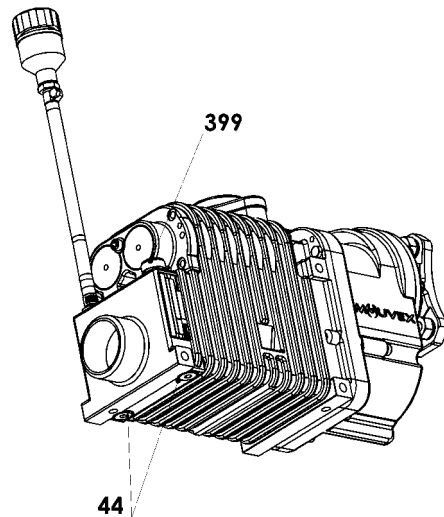

5. MAINTENANCE (continued)

5.3 Inlet shaft replacement

The B200 PF inlet shaft has a groove that breaks the shaft in case of excess torque, as required to protect the gear box and the PTO.

Before replacing the inlet shaft, it is essential to make sure that the compressor is not damaged :

- Loosen and remove the 8 screws **1095**.
- Remove the wheel, complete with the remaining part of the shaft.
- Rotate the wheel **6** manually and check that it can rotate freely and without any hard point over a complete rotation.
- Inspect the screws on the discharge part and make sure that there are not any marks of contact between the screws, or due to the presence of any foreign bodies.



The compressor is to replace if :

- wheel **6** does not rotate.
- wheel **6** cannot rotate easily.
- marks can be seen on the screws.
- Engage the bearing of shaft kit **1071** in the housing of casing **1086**.
- Check the state of the lip seals **1089** and the O'ring **40**. Make sure that they are not damaged.
- Engage the lantern **230** in the desired position.
- Tighten the 8 screws **1095**.

For the installation of the compressor on the power take-off, refer to § DIRECT INSTALLATION ON B200 PF TRUCK POWER TAKE-OFF.

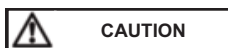

Screws **1095** must be :

- equipped with their lock washers, notches on the side of the screw head,
- sealed with Loctite® * thread locking 243 or equivalent,
- tightened at 13 Nm.

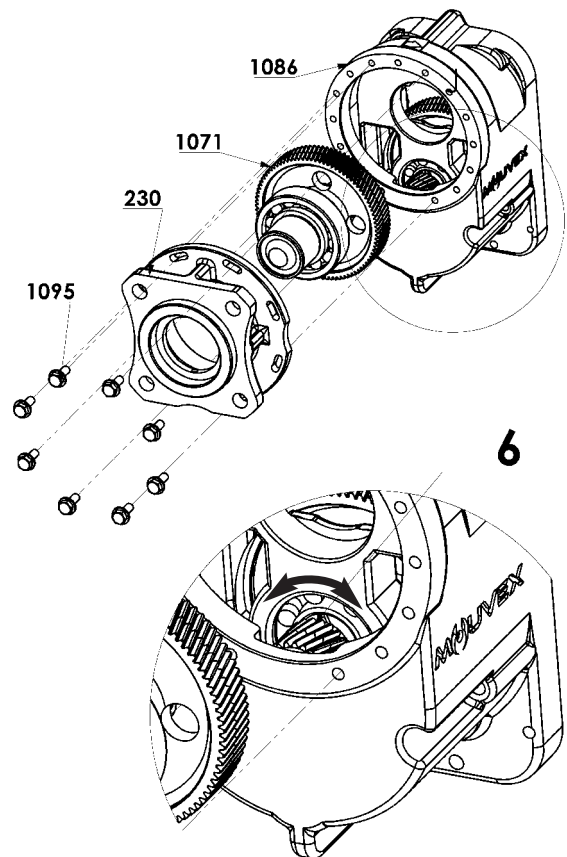

* Loctite® is a registered trademark.

6. TROUBLESHOOTING

CAUTION :
OBSERVE ALL SAFETY WARNINGS CONTAINED IN THIS MANUAL.

Problem	Possible origin	Possible solution
1. Pressure issue	Too much pressure drop.	To check pipes diameter.
	Relief valve damaged.	To check the opening point.
	No return valve damaged.	To check the proper operating of the No return valve.
2. Flow rate issue	Wrong Compressor speed.	To adjust the speed by taking care of the range allowed.
	Relief valve damaged.	To check the opening point.
3. Abnormal high temperature	Air filter clogged.	To clean the cartridge or to replace it.
	Air pressure too much high.	To see problems 1. / 2.
	Outside temperature too much high.	To respect the maximum external temperature allowed.
	Lack of oil.	To check the oil level.
	Compressor speed too much low.	To adjust the speed by taking care of the range allowed.
4. Inlet pressure drop > 75 mbar (clogging indicator red)	Air filter clogged.	To clean the cartridge or to replace it.
	Air inlet hose folded.	To check the air inlet hose.
5. Compressor doesn't operate	Torque limiter damaged.	To replace the torque limiter.
	Transmission damaged.	To consult your Service point.
6. Torque limiter damaged	Screw Compressor damaged.	To consult your Service point.
	Wrong motor / transmission management.	To consult your Truck dealer.
	Oil too much viscous.	To be in compliance with the MOUVEX Instructions.
7. Oil leak	Too much oil.	To check the oil level.
	Oil breather clogged.	To clean the oil breather.
8. Vibrations	Wrong motor speed.	To increase the speed by taking care of the range allowed.
	Transmission damaged.	To check the driving shaft.
	Lack of rigidity of the chassis.	To be in compliance with the Truck Manufacturer Instructions.

7. WARRANTY

7.1 Warranty claims

The compressor oil is considered as wear part.

No failure connected with wear part damage will be accepted under warranty conditions.

The following situations will void warranty for all components of the compressor :

- Installation not in accordance with the CL 1401-001 Control check list installation B200 FC.
- No MOUVEX Check relief valve.
- Tampering with the setting of the relief valve.
- Presence of foreign body inside the compressor body.
- Traces of damage representative of abnormal use of the compressor.
- Use of non genuine parts.
- If the compressor is repaired by a repairer who is not a MOUVEX-approved repairer.
- Construction of the package not validated by our Design Office.
- Use of an oil other than BSC2 (provide invoices).
- Presence of a dumping valve on the pipe linking the compressor to the tank hose connector.
- Motor management not fixed, allowing the operator a using outside the working range.

Before returning your equipment to the factory, you must first obtain an Equipment return approval (RMA) from our After Sales Department.

A Compressors form information shall be filled by the installer or distributor and send to MOUVEX in order to claim for a warranty.

7.2 24-months warranty extension

The 24-months warranty extension option increases the warranty for the screw compressor to 60 months :

- Europe zone only,
- Only concerns the bare shaft compressor with or without multiplier, excluding kits and accessories (air filter, torque limiter, check relief valve...),
- Use of BSC2 oil (provide invoices),
- Conditions identical to the current standard warranty.

8. STORAGE CONDITIONS

8.1 Compressor

The equipment must be systematically stored in an area sheltered from bad weather.

The equipment must bear its original protective components until it is installed in its final application.

If installation is interrupted, put back in place the original protective components or equivalent components.

8.2 BSC2 oil

In its unopened original container in a dry, frost-free and light-free place.

The maximum shelf life is approx. 60 months.

9. SCRAPPING

The compressor must be scrapped in compliance with the regulations in force.

During this operation, particular care must be paid to the drainage stages of the compressor.

10. COMPRESSORS FORM INFORMATION

Before any material return, it is required to get an authorization from MOUVEX.



After Sales Department

Z.I. La Plaine des Isles - 2 rue des Caillottes - 89000 AUXERRE - FRANCE

+33 3 86 49 87 25 - sav.mouvex@psqdoover.com

COMPRESSORS FORM INFORMATION

In order to treat correctly the warranty claims, please first complete this information form.
Thanks to return us this completed document by email as soon as possible.

NAME, ADDRESS AND PHONE NUMBER OF THE CUSTOMER

Material purchased by :

Material mounted by :

Material used by :

Person to contact for technical information :

EQUIPMENT CONCERNED

Screw compressor Vane compressor Type :

Delivery date : Starting-up date :

Serial N° : Running time estimation (hours) :

Have you already replaced the equipment by a new one ? Yes No If yes, indicate its serial N° :

TYPE OF INSTALLATION

Direct PTO drive

Belt drive system

Torque limiter (value) :

Pressure relief valve setting (value) :

Package DDNC Package DDIC

Other (electric, diesel or hydraulic motor)

Brief description :
(please join a drawing or pictures of the installation)

OPERATING PARAMETERS

Compressor's speed : rpm

Operating pressure : bar

Motor speed at the time or the incident : rpm

PTO ratio :

Product transfered :

SUCTION CONDITIONS

Air connection on truck chimney

Direct air connection

Flexible pipe between filter and compressor

Stainless steel pipe between filter and compressor

Filter type :

DESCRIPTION OF THE MATTER

Leakage Insufficient flow Insufficient pressure

Blocking Noise / vibration Other :



IN CASE OF RETURN OF MATERIAL TO OUR FACTORY, PLEASE REQUEST IMPERATIVELY BEFORE SENDING THE MATERIAL RETURN AUTHORIZATION (RMA) WHICH WILL BE PROVIDED TO YOU BY MOUVEX AFTER SALES DEPARTMENT.