



**INSTRUCTIONS 208-A00 e**

Section	208
Effective	March 2023
Replaces	February 2018

Original instructions

# **ENTERPRISE**

## **E140 - E170**

**E140**



**E170**



**E140 HYD**



**INSTALLATION**

**OPERATION**

**MAINTENANCE**

**EC CERTIFICATE OF CONFORMITY :**

The EC Certificate of Conformity (paper version) is systematically attached to the equipment when shipped.

**WARRANTY :**

ENTERPRISE compressors are covered 24 months by warranty within the limits mentioned in our General Sales Conditions. In case of a use other than that mentioned in the Instructions manual, and without preliminary agreement of MOUVEX, warranty will be canceled.



Z.I. La Plaine des Isles - F 89000 AUXERRE - FRANCE  
Tel. : +33 (0)3.86.49.86.30 - Fax : +33 (0)3.86.49.87.17  
contact.mouvex@psgdover.com - www.mouvex.com

Your distributor :

# MOUVEX ROTARY VANE COMPRESSORS

## INSTALLATION, OPERATION, AND MAINTENANCE INSTRUCTIONS

### MODELS : E140 - E170

TABLE OF CONTENTS	Page
<b>1. OVERALL DIMENSIONS</b> .....	<b>4</b>
1.1 E140 .....	4
1.2 E170 .....	5
<b>2. TECHNICAL DATA</b> .....	<b>6</b>
<b>3. INSTALLATION</b> .....	<b>6</b>
3.1 Compressor mounting .....	6
3.2 Drive systems .....	7
3.3 Drive shaft - See Figure 5 .....	8
3.4 Hydraulic drive .....	8
3.5 Piping .....	9
<b>4. USE</b> .....	<b>11</b>
4.1 Starting-up .....	11
<b>5. MAINTENANCE</b> .....	<b>12</b>
5.1 Maintenance schedules .....	12
5.2 Quick blade inspection (E140 only) .....	13
5.3 Sideplate removal .....	13
5.4 Blade removal and inspection .....	14
5.5 Rotor inspection .....	14
5.6 Sideplate disassembly .....	15
5.7 Sideplate assembly .....	15
5.8 Setting sideplate clearance .....	16
5.9 Compressor assembly .....	17
5.10 Initial start up / Reinstallation .....	18
<b>6. TROUBLESHOOTING</b> .....	<b>18</b>
<b>7. SCRAPPING</b> .....	<b>18</b>
<b>8. COMPRESSORS FORM INFORMATION</b> .....	<b>19</b>

**NOTE :**

Numbers in parentheses following parts indicate reference numbers on the ENTERPRISE Rotary Vane Compressor Parts List 208-A01.

#### Definition of safety symbols



This is a SAFETY ALERT SYMBOL.

When you see this symbol on the product, or in the manual, look for one of the following signal words and be alert to the potential for personal injury, death or major property damage.



Warns of hazards that WILL cause serious personal injury, death or major property damage.



Warns of hazards that CAN cause serious personal injury, death or major property damage.

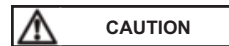

Warns of hazards that CAN cause personal injury or property damage.

#### NOTICE

Indicates special instructions which are very important and must be followed.

#### SAFETY DATA

ENTERPRISE compressors MUST only be installed in systems which have been designed by qualified engineering personnel. The system MUST conform to all applicable local and national regulations and safety standards.

This manual is intended to assist in the installation and operation of the ENTERPRISE compressors, and MUST be kept with the compressor.



ENTERPRISE compressor service and maintenance shall be performed by qualified technicians ONLY. Service and maintenance shall conform to all applicable local and national regulations and safety standards.



Thoroughly review this manual, all instructions and hazard warnings, BEFORE performing any service or maintenance on the ENTERPRISE compressors.



Maintain ALL system and ENTERPRISE compressor operation and hazard warning decals.



# SAFETY DATA

## SAFETY CHECKLIST

 <b>WARNING</b>	<p><b>COMPRESSING GASES INTO A VESSEL CONTAINING FLAMMABLE OR EXPLOSIVE GASES OR COMPRESSING FLAMMABLE OR EXPLOSIVE GASES, CAN CAUSE PROPERTY DAMAGE, PERSONAL INJURY OR DEATH.</b></p>
	
<p>Hazardous fluids can cause fire, serious personal injury or property damage.</p>	

 <b>WARNING</b>	<p><b>FAILURE TO INSTALL ADEQUATELY SIZED PRESSURE RELIEF VALVE(S) CAN CAUSE PROPERTY DAMAGE, PERSONAL INJURY OR DEATH.</b></p>
	
<p>Hazardous pressure can cause personal injury or property damage.</p>	

 <b>CAUTION</b>	<p><b>COMPRESSOR, PIPING AND ACCESSORIES WILL BECOME HOT DURING OPERATION AND CAN CAUSE SERIOUS PERSONAL INJURY.</b></p>
	
<p>Extreme heat can cause injury or property damage.</p>	

 <b>WARNING</b>	<p><b>CONTENTS OF THE COMPRESSOR, TANK, PIPING, AND FILTERS COULD BE HAZARDOUS TO HEALTH. TAKE ALL NECESSARY PRECAUTIONS WHEN PERFORMING COMPRESSOR SERVICE OR MAINTENANCE.</b></p>
	
<p>Hazardous or toxic fluids can cause serious injury.</p>	

1. Before operating the compressor, ensure the vessel to which the compressor is connected is certified to withstand the pressure and /or vacuum produced.
2. Verify adequately sized relief valves have been fitted to protect the vessel.
3. Gas/air mixtures which are potentially volatile/explosive must not be introduced or allowed to be introduced into the compressor.
4. All pressure vessel and piping connected to the compressor must be isolated and in a safe operating condition.
5. Operators should wear ear protection when operating truck mounted compressors.
6. There are components within the compressor of sufficient weight to cause injury if mishandled. Use proper lifting devices as necessary.
7. Where necessary, this equipment should be grounded to control static electricity.
8. The temperature of the air leaving the compressor is elevated above ambient due to air compression. Check that the elevated temperatures do not adversely affect the product and any material used in design of the system. Attach clearly marked warning signs to warn of potentially hot surfaces on the compressor, piping and accessories which will burn if touched.
9. Mounting of the compressor must be correctly engineered and the compressor must be properly secured. Refer to the § "COMPRESSOR ASSEMBLY" of this manual.

### NOTICE

**ENTERPRISE COMPRESSORS ARE NOT DESIGNED FOR HANDLING LIQUID OR CONDENSATE. TO DO SO WILL VOID THE WARRANTY.**

# 1. OVERALL DIMENSIONS

## 1.1 E140

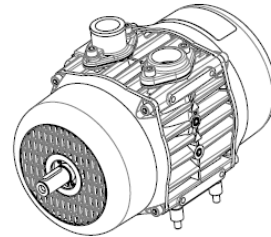
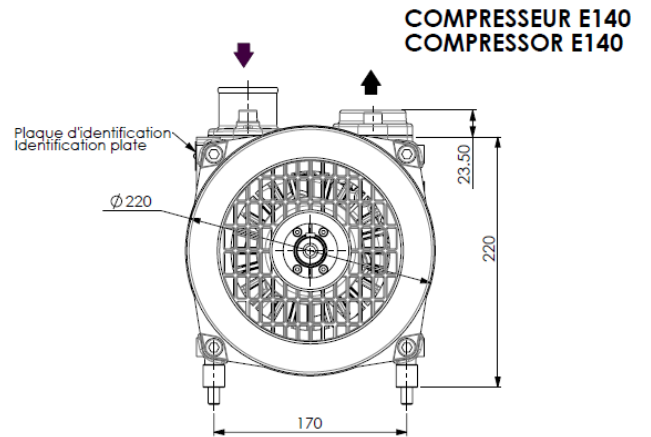
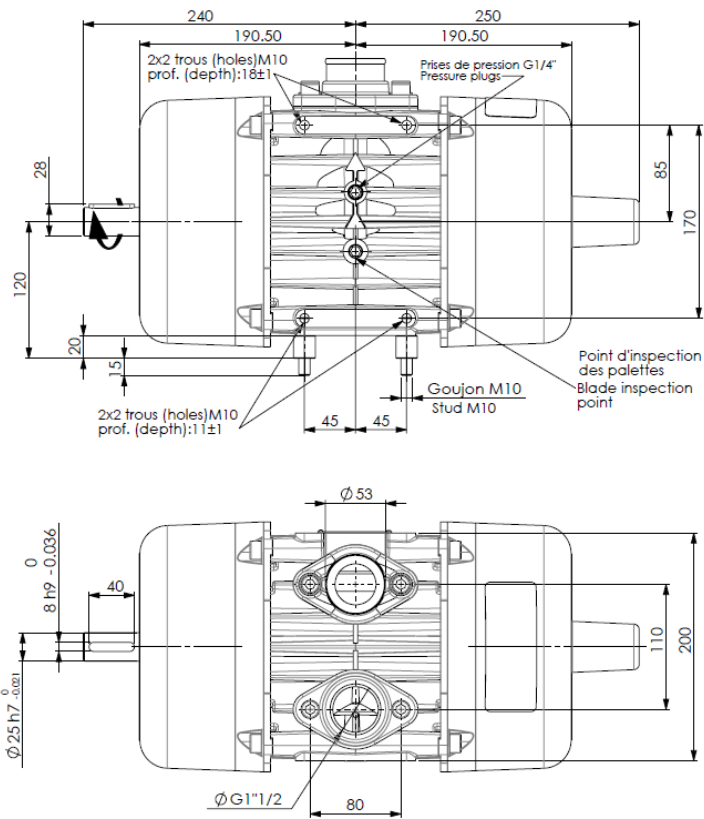

## KIT MOTEUR HYDRAULIQUE E140 HYDRAULIC MOTOR KIT E140

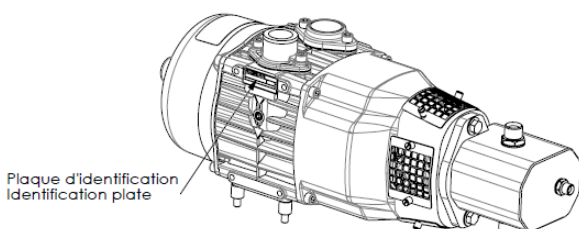
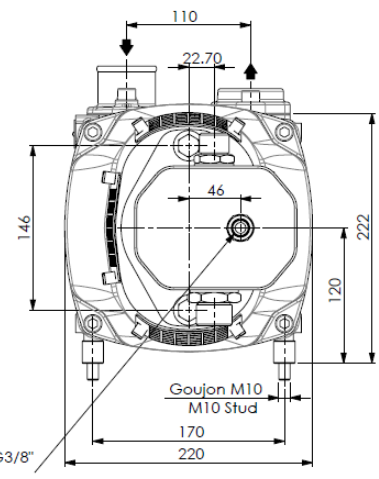
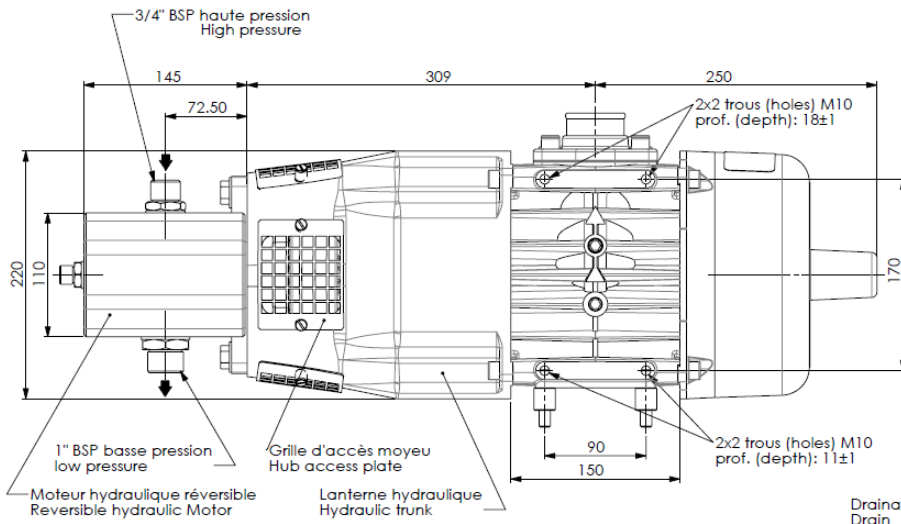

# 1. OVERALL DIMENSIONS (continued)

## 1.2 E170

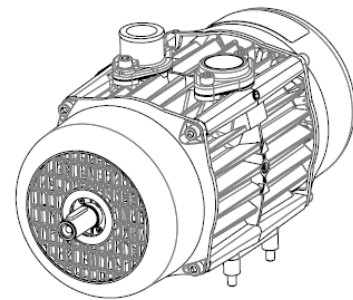
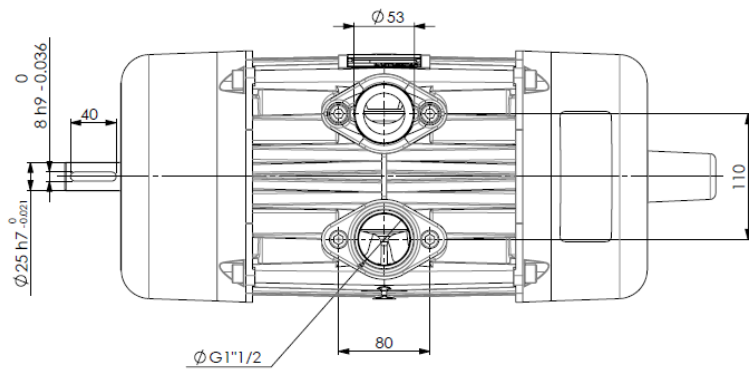
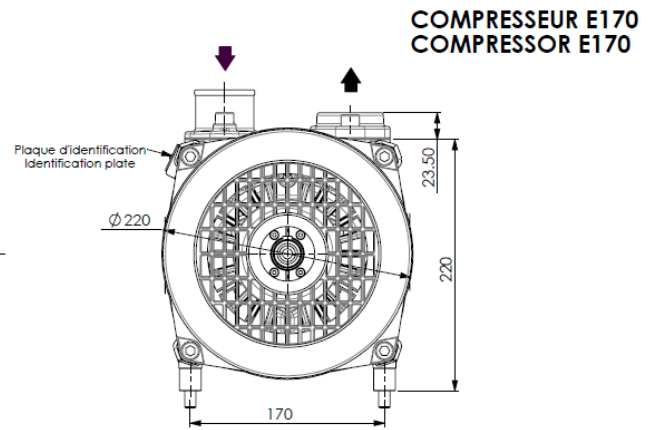
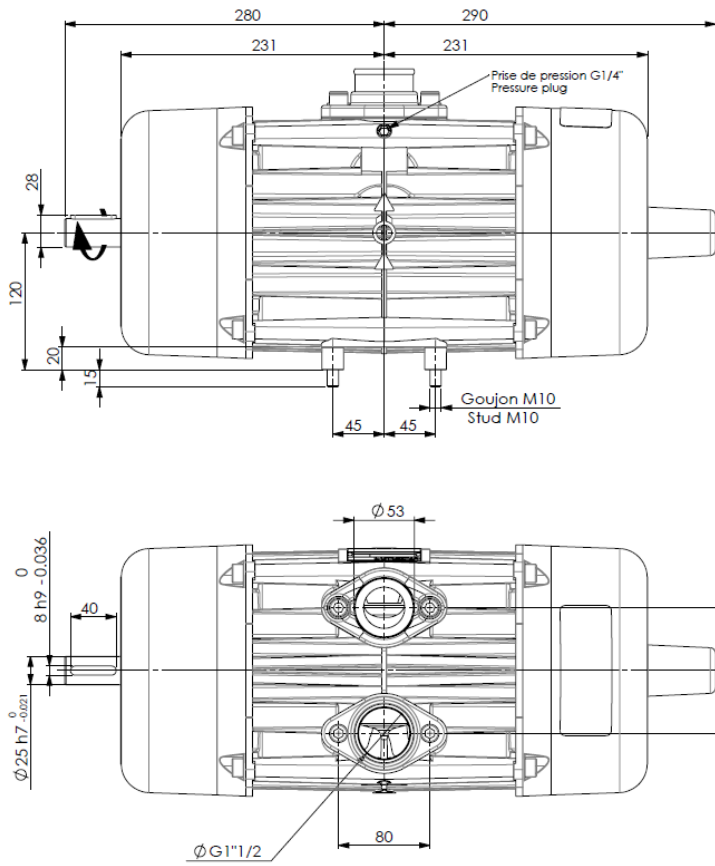

## KIT MOTEUR HYDRAULIQUE E170 HYDRAULIC MOTOR KIT E170

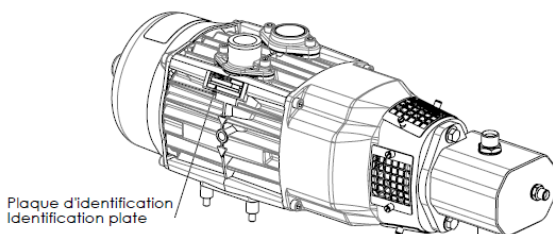
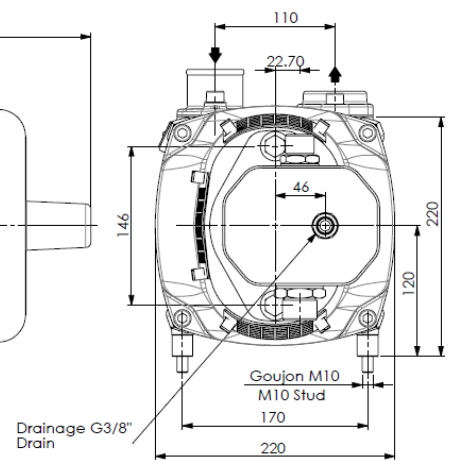
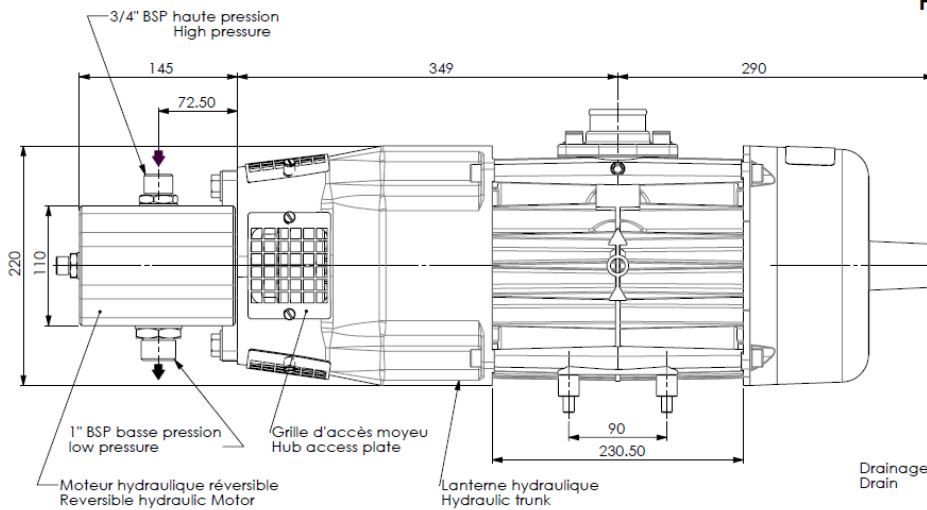

## 2. TECHNICAL DATA

Models	E140	E170
Maximum Air	82 cfm (140 m <sup>3</sup> /h)	102 cfm (173 m <sup>3</sup> /h)
Weight	36 kg (79 lbs)	47 kg (104 lbs)
Power absorbed*	11,5 PS (8,5 kW)	13,7 PS (10,2 kW)
Maximum pressure (continuous)	36 psi (2,5 bar)	29 psi (2,0 bar)
Maximum compressor speed	1.750 rpm	1.600 rpm
Standard Rotation <sup>1</sup>	Counterclockwise	

\* E170 @ 1500 RPM and 29 psi; E140 @ 1500 RPM and 36 psi.

<sup>1</sup> Clockwise rotation optional - must be specified at time of order.

### NOTICE :

**COMPRESSOR SPEED AND PRESSURE MUST FALL WITHIN THE SHADED AREA OF THE GRAPH AT RIGHT.**

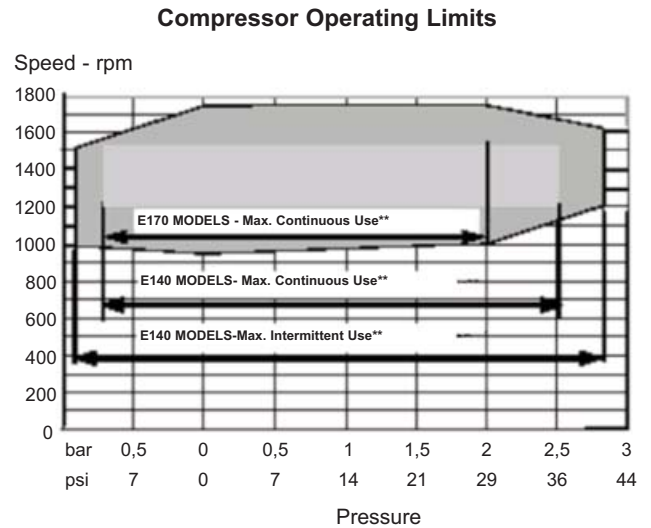

▭ = Best operating conditions for longest compressor life.

\*\* Continuous Use = Greater than 20 minutes.

## 3. INSTALLATION

### 3.1 Compressor mounting

- The E140 compressor has mounting points on both sides of the body, as well as the base. The compressor can be mounted using the studs and spacers provided. See Figure 1. In addition to the standard mounting bracket, MOUVEX can supply brackets to suit existing installations currently using other makes of compressors.

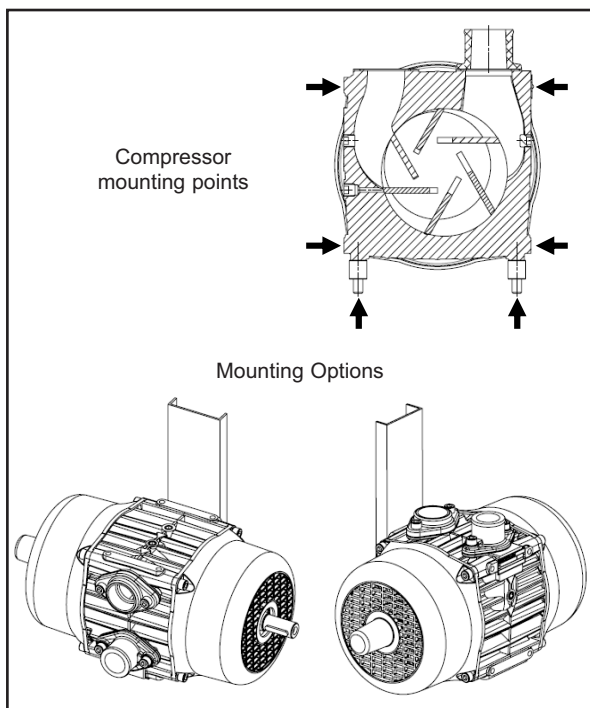

Figure 1 - Mounting

- The compressor can be driven from either end, however the drive shaft **MUST** always be horizontal +/- 5°. See Figure 2.

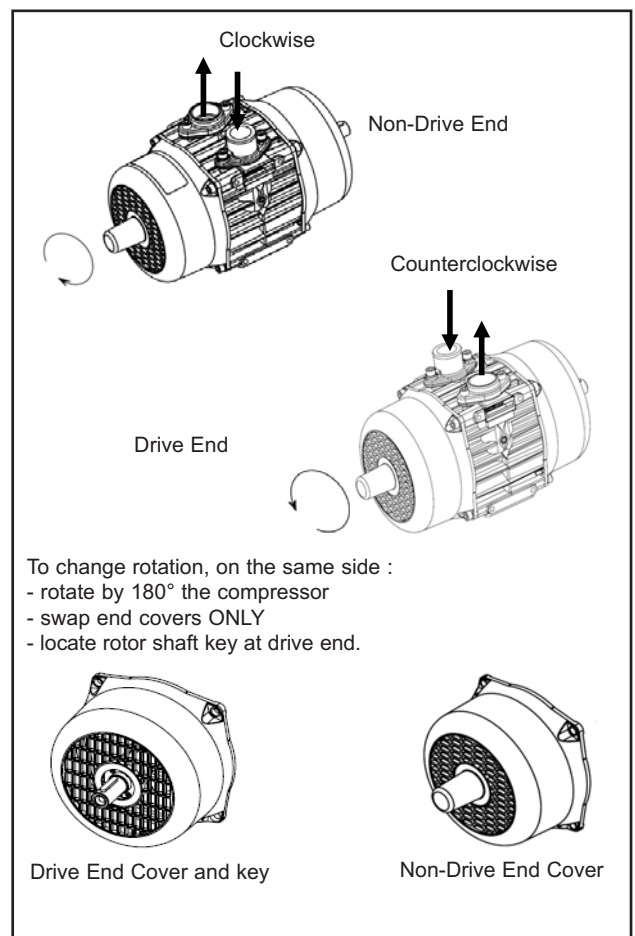

Figure 2

### 3. INSTALLATION (continued)

3. Ensure that the compressor rotates in the direction of the arrows cast on the body. See Figure 3.

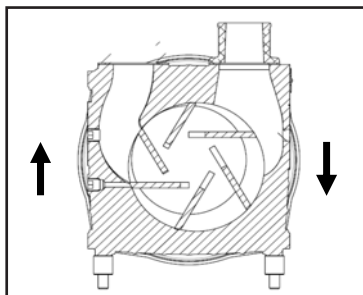

Figure 3 - Rotation

4. Mount the compressor in a position where it is protected from dirt, debris and road spray. The mounting location should allow for regular inspection, cleaning and maintenance. The inlet filter should be positioned to draw in clean, cool air, and should be mounted away from any engine heat and exhaust. See Figure 4.

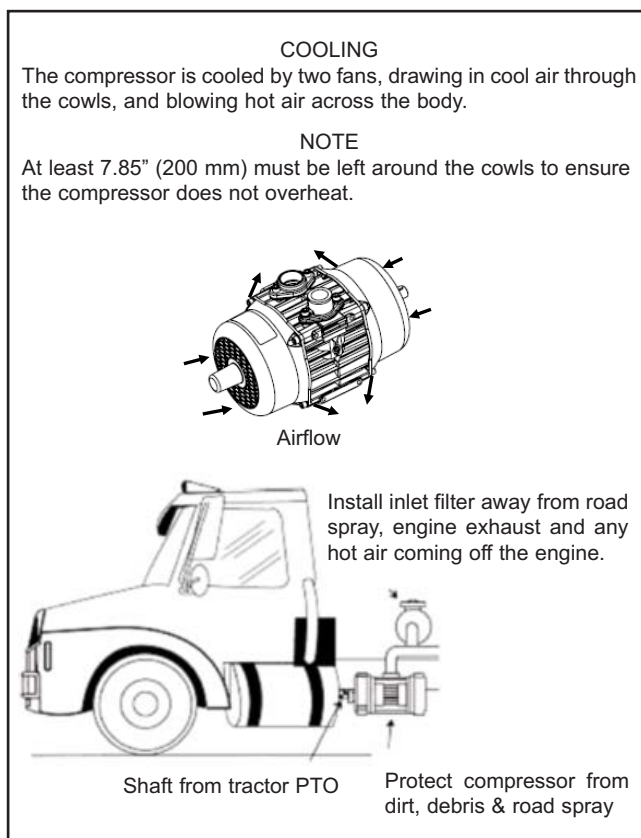

Figure 4

#### 3.2 Drive systems



A variety of drive options are available for the compressor, including vehicle mounted, drive shaft, hydraulic motor and flexible coupling. CAREFULLY follow all the recommendations provided here for your application. In ALL cases, the drive shaft MUST be capable of providing for a constant compressor speed and MUST NOT subject the compressor to excessive start-up torques.

##### Driver - Vehicle mounted

1. Speed governors are required.
2. Power Take-off (PTO) MUST provide for the correct compressor operating speed. If PTO gear box has a "High/Low" range, ensure that the correct range is selected.

### 3. INSTALLATION (continued)

#### 3.3 Drive shaft - See Figure 5

 <b>WARNING</b>	<p>DRIVES SHAFTS MUST BE GUARDED IF EXPOSED. OPERATION WITHOUT GUARDS CAN CAUSE SERIOUS PERSONAL INJURY, MAJOR PROPERTY DAMAGE OR DEATH.</p>
	
<p>Do not operate without guard in place.</p>	

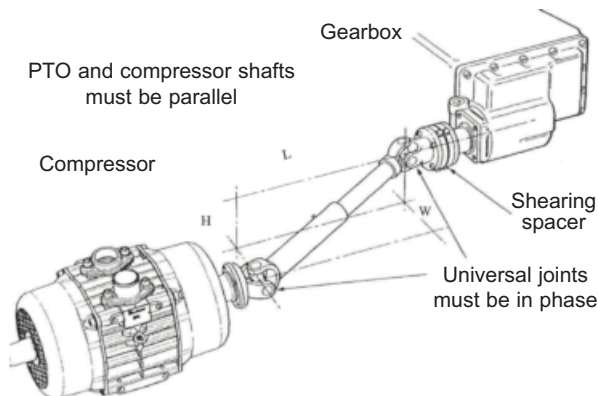

**Figure 5**

1. Square slip joints are NOT recommended.
2. Drive shaft length should be as short as possible and the drive shaft MUST be balanced.
3. The drive shaft and compressor shaft MUST be parallel within 1° and have a maximum of 10° compound misalignment. See Table :

$$A = \frac{\sqrt{H^2 + W^2}}{L}$$

If H = Zero, A = W / L

If W = Zero, A = H / L

A	Universal joint angle	
0,017	1°	VERY GOOD
0,035	2°	
0,052	3°	
0,070	4°	
0,087	5°	GOOD
0,105	6°	
0,125	7°	
0,141	8°	
0,158	9°	LIMIT VALUES
0,176	10°	
0,194	11°	
0,213	12°	
0,231	13°	
0,249	14°	
0,268	15°	

4. Universal joints MUST be in phase, with the drive shaft slip joint at mid-position. Use an even number of universal joints.
5. If the drive shaft is fitted to a PTO, a torque limiting device MUST be fitted to prevent damage due to possible compressor failure/seizure.

#### 3.4 Hydraulic drive

1. If the compressor is to be driven hydraulically, MOVEX can supply a standard Drive Kit for direct mounting of the hydraulic motor or hydraulic pump. MOVEX can also supply the hydraulic motor ; See figure 6.

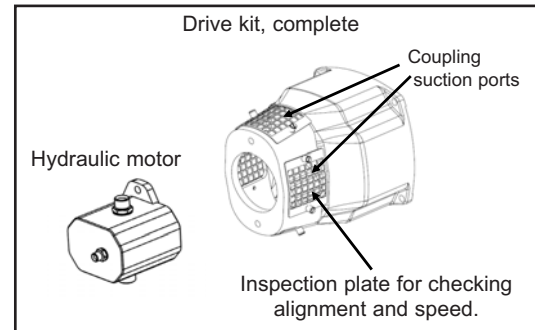

**Figure 6**

2. Ensure the motor is installed and piped to give the correct rotation. If required, a drain line, returning to hydraulic reservoir tank, should also be installed.
3. If the couplings are aligned correctly, the outer plastic sleeve should have 0.19 inch (5 mm) axial play through 360° rotation. This can be checked by removing the inspection plate ; See figure 6.

 <b>WARNING</b>
---

**THE DISCHARGE PIPE OF THE COMPRESSOR (THE TEMPERATURE CAN BE OVER 200°C) CAN NOT GO CLOSE TO THE COUPLING SUCTION PORTS. IF NOT POSSIBLE TO AVOID IT, INSTALL A DEFLECTOR TO PROTECT THE COUPLING FROM SUCKING HOT AIR.**

#### Base mounted direct drive Flexible coupling

When base mounted and coupled to a drive (i.e.: electric motor), use a flexible coupling.

1. Coupling angular and parallel alignment MUST be maintained in accordance with coupling manufacturer's instructions ; See figure 7.

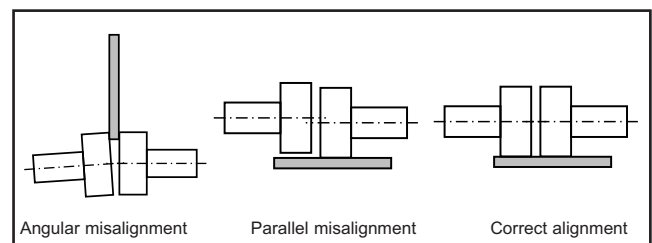

**Figure 7- Coupling alignment**

#### NOTICE :

**USE OF EXCESSIVE FORCE WHEN FITTING THE COUPLING FLANGE TO THE COMPRESSOR SHAFT CAN CAUSE BEARING DAMAGE AND INTERNAL COMPRESSOR DAMAGE.**

2. When an electric motor is utilized as the driver, it MUST be fitted with adequately sized overload protectors to safeguard it against compressor seizure.



### 3. INSTALLATION (continued)

#### 3.5 Piping

1. Piping MUST be at least as large as the compressor suction and discharge connections.

ALL piping MUST be adequately supported to prevent any piping loads from being placed on the compressor.

2. The suction side of the compressor MUST be fitted with an adequately sized air filter, which MUST be protected from water, road spray, or other debris. This filter is available from MOUVEX. Use of wrong filter will void warranty. The compressor is delivered with an inlet connection kit which is installed as follows :

#### Composition of the kit :



Item	Description	Quantity
152A	Heat shrinkable sleeve	2
164	Hose (length 2 meters)	1
165-166	Clamp	2
884	Hump	2XØ50 (black)

#### Assembling procedure :

- To cut the hose to the length requested.
- To fold back the end of the wire inside.



- To screw home the humps at the 2 ends.



- Result :



- To pass a heat-shrinkable sleeve on an end and to center it on the end of the hump. To retract gradually by means of a heat gun. Attention not to point the gun towards the hose not covered, risk of perforation.

To proceed in the same way at the other end.



- To check the hose is perfectly clean inside, and to remove the protections caps on the compressor.

### 3. INSTALLATION (continued)

- To assemble the unit on the compressor inlet port and to tighten the clamp : aluminium flange.

Example with B200 :



- To proceed in the same way with the air filter.



- To then suspend the hose while taking care to protect it from any friction and the potentially hot bodies such as muffler.

- The compressor MUST have an adequately sized pressure relief valve installed approximately 30 inches after the compressor discharge ; See figure 8.

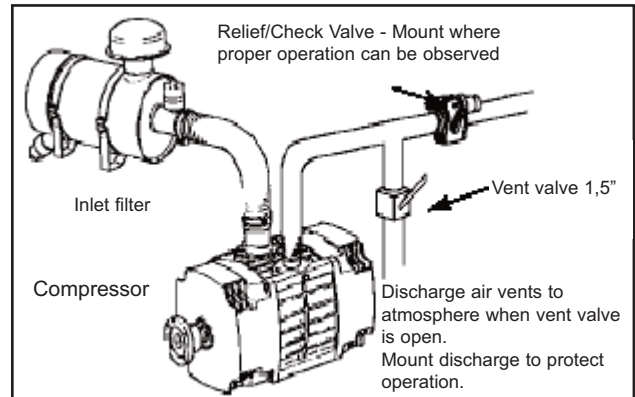



Figure 8 - Typical compressor installation



- If a backflow is possible, an adequately sized check valve MUST also be installed in the discharge piping. This check valve MUST NOT be mounted in a way that broken pieces could fall into the compressor. ENTERPRISE combination relief/check valves are supplied with all Enterprise compressors and MUST be used.
- Ensure that ALL components are capable of operation at the maximum system pressure limits and that all vessels are adequately protected by SEPARATE relief valves.

**NOTICE :**

**ROTATION MUST MATCH ARROWS CAST ON COMPRESSOR BODY. REVERSE ROTATION WILL SEVERELY DAMAGE COMPRESSOR AND VOID WARRANTY.**

 <p><b>WARNING</b></p>	<p><b>FAILURE TO INSTALL ADEQUATELY SIZED PRESSURE RELIEF VALVE(S) CAN CAUSE PROPERTY DAMAGE, PERSONAL INJURY OR DEATH.</b></p>
 <p><b>Hazardous pressure can cause personal injury or property damage.</b></p>	

## 4. USE

 <b>WARNING</b>	<p>COMPRESSING GASES INTO A VESSEL CONTAINING FLAMMABLE OR EXPLOSIVE GASES OR COMPRESSING FLAMMABLE OR EXPLOSIVE GASES, CAN CAUSE PROPERTY DAMAGE, PERSONAL INJURY OR DEATH.</p>
	
<p>Hazardous gases can cause property damage, personal injury or death.</p>	

### NOTICES :

FAILURE TO OPERATE COMPRESSOR WITHIN THE SHADED LIMITS INDICATED IN THE § "TECHNICAL DATA", CAN RESULT IN BLADE BOUNCE, EXCESSIVE BLADE WEAR, CHIPPING OR BREAKAGE.

REVIEW THE § "SAFETY DATA" OF THIS MANUAL AND FOLLOW ALL HAZARD WARNINGS AND NOTICES BEFORE OPERATING COMPRESSOR.

COMPRESSOR MUST OPERATE AT FIXED SPEED WITHIN THE COMPRESSOR MODEL SPEED LIMITS. SPEED MUST REMAIN CONSTANT THROUGHOUT THE OFF LOADING OPERATION.

ROTATION MUST MATCH ARROWS CAST ON COMPRESSOR BODY. REVERSE ROTATION WILL SEVERELY DAMAGE COMPRESSOR AND VOID WARRANTY.

THE OPERATOR SHOULD REMAIN NEARBY THE EQUIPMENT THROUGHOUT THE USE TO ENSURE THE PROPER FUNCTIONING OF THE SYSTEM.

THE DESIGN OF THE COMPRESSORS ENTERPRISE REQUIRES WEAR COMPONENTS AS THE VANES IN CARBON THAT CAN PRODUCE DUST PARTICLES. THEREFORE, THE USE OF A DISCHARGE FILTER IS MANDATORY FOR FOOD GRADE AND SENSITIVE APPLICATIONS.

IT IS IMPERATIVE TO HOLD THE HOSE IN ORDER TO AVOID WHIPPING DURING PRESSURIZATION.

	<p><b>WARNING: SEVERE PERSONAL INJURY OR PROPERTY DAMAGE CAN CAUSE FROM WHIPPING HOSES.</b></p>
---	---

### 4.1 Starting-up

BEFORE starting compressor, open all air valves necessary to vent the tank and compressor to atmosphere.

Verify there is no possibility of operating at pressure before compressor reaches correct speed.

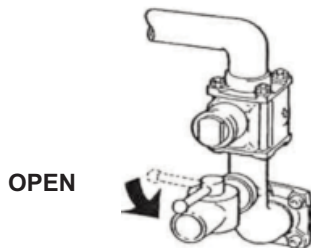

Close all valves and proceed to pressurize the tank and discharge the cargo.



#### 4.1.1 Start-up procedure for manual gear box

- Start the engine and run with standard speed.
- Depress clutch and engage the PTO.
- Release the clutch SLOWLY.
- Set engine speed to give the correct compressor speed.



#### 4.1.2 Shutting down procedure for manual gear box

- Depress the clutch and disengage the PTO.



- Reduce engine speed to idle.



**ALWAYS DISENGAGE THE DRIVE BEFORE SLOWING ENGINE DOWN.**



- Release the clutch.







### NOTICE :



**COMPRESSOR MUST OPERATE AT FIXED SPEED WITHIN THE COMPRESSOR MODEL SPEED LIMITS. SPEED MUST REMAIN CONSTANT THROUGHOUT THE OFF LOADING OPERATION.**

## 5. MAINTENANCE

	<b>WARNING</b>
	<p>FAILURE TO SET THE VEHICLE EMERGENCY BRAKE AND CHOCK WHEELS BEFORE PERFORMING SERVICE CAN CAUSE SEVERE PERSONAL INJURY OR PROPERTY DAMAGE.</p>
<p>Hazardous machinery can cause severe personal injury or property damage.</p>	

	<b>WARNING</b>
	<p>FAILURE TO RELEASE ALL SYSTEM AIR AND WHEN EQUIPPED, HYDRAULIC PRESSURE, CAN CAUSE PROPERTY DAMAGE, PERSONAL INJURY OR DEATH.</p>
<p>Hazardous pressure can cause personal injury or property damage.</p>	

	<b>WARNING</b>
	<p>DISCONNECT THE ELECTRICITY SUPPLY BEFORE ANY MAINTENANCE OPERATION.</p>
<p>Dangerous voltage. Can cause injury and death.</p>	

	<b>CAUTION</b>
	<p>COMPRESSOR, PIPING AND ACCESSORIES WILL BECOME HOT DURING OPERATION AND CAN CAUSE SERIOUS PERSONAL INJURY.</p>
<p>Extreme heat can cause injury or property damage.</p>	

**NOTICE :**

COMPRESSOR SERVICE AND MAINTENANCE SHALL BE PERFORMED BY QUALIFIED TECHNICIANS ONLY AND SHALL CONFORM TO ALL LOCAL AND NATIONAL CODES, REGULATIONS AND SAFETY STANDARDS.

**NOTICE :**

FOLLOW ALL HAZARD WARNINGS AND NOTICES PROVIDED IN THE § "SAFETY DATA" OF THIS MANUAL BEFORE PERFORMING COMPRESSOR SERVICE OR MAINTENANCE.

### 5.1 Maintenance schedules

**Daily**

1. The compressor should be run once a day for at least 15 minutes to prevent moisture from collecting inside. This will reduce the risk of corrosion damage to the compressor and other equipment in the piping.
2. After washing the vehicle, always run the compressor for 15 minutes to remove any water that inadvertently gets into the piping. DO NOT fog or introduce anti-corrosive liquids into the compressor to prevent corrosion. Use of liquids in the compressor will cause failure.

**Weekly**

1. Inspect and clean air filter. Clean the compressor external surfaces and cooling fins. Inspect DAILY if operating in dirty or severe environment. Check the condition of the inlet filter hose for splits and tears. Replace as necessary.
2. Inspect compressor, system piping and components. Clean or repair as necessary.

**Monthly**

1. When equipped, inspect and grease the drive shaft universal joints.
2. Check the relief valve(s) for wear and proper settings. Replace or adjust as necessary.
3. Inspect the compressor grease seals and replace as necessary.
4. As conditions require, clean the compressor external surfaces and cooling fins. DO NOT allow cleaning fluids to enter the compressor inlet.

#### 5.1.1 BEARINGS

The bearings are filled up with grease during the assembling of the compressor in our workshop.

The grease must be changed every 1000 hours of operation and does not require intermediate topping up. See § 5.7 SIDEPLATE ASSEMBLY.

This renewal must be associated with the control and replacement if necessary, of the vanes. See § 5.4 BLADE REMOVAL AND INSPECTION.

## 5. MAINTENANCE (continued)

### 5.1.2 BLADE INSPECTION

For typical applications blades should be inspected every 1000 hours, and replaced if worn below 1.57" (40 mm). See Figure 9.

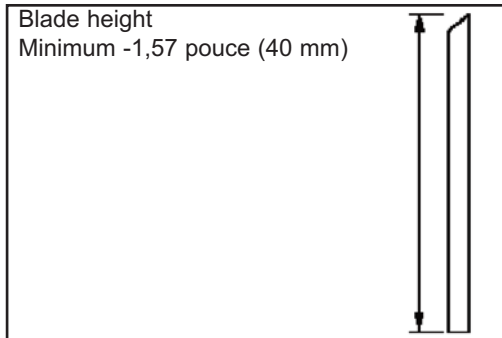

Figure 9

For higher duty operation (running in pressures over 29 psi or 2 bar), inspect the compressor blades every 500 hours.

Blade inspection and replacement may be performed with compressor installed. The compressor should be cleaned before proceeding.

### 5.2 Quick blade inspection (E140 only)

The blades can also be inspected without disassembling the compressor using the following procedure :

1. Remove the 1/4" BSP plug on the compressor body.
2. Use a vernier caliper to measure the blade wear as shown in 10.

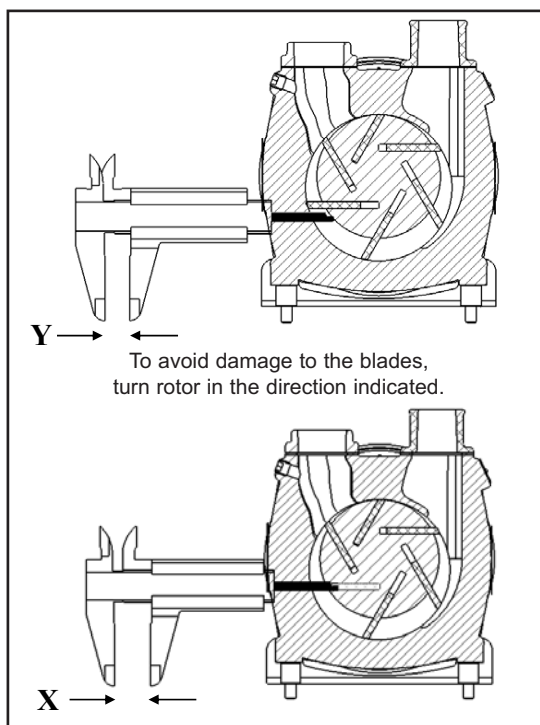

Figure 10 - Quick Blade Inspection

3. If the measurement of X - Y is greater than 10 mm (0.4") replace the blades.

### 5.3 Sideplate removal

1. Disconnect the compressor from the driver and remove the shaft key (16).
2. Remove the four M10 screws (8) securing the cowl, and remove the cowl (12 or 13) ; See figure 11.

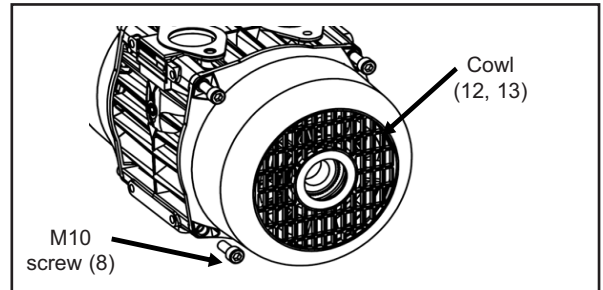

Figure 11

3. Loosen the the four M8 set screws (10) holding the split sleeve, and remove the split sleeve (4) ; See figure 12.

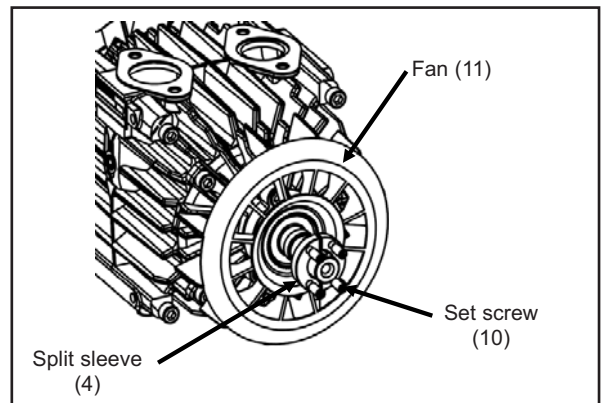

Figure 12

4. Remove the fan (11). Inspect the split sleeve and fan for damage and replace as necessary.
5. Remove the three M10 sideplate capscrews (7) and the M8 sideplate shoulder screw (9) ; See figure 13.

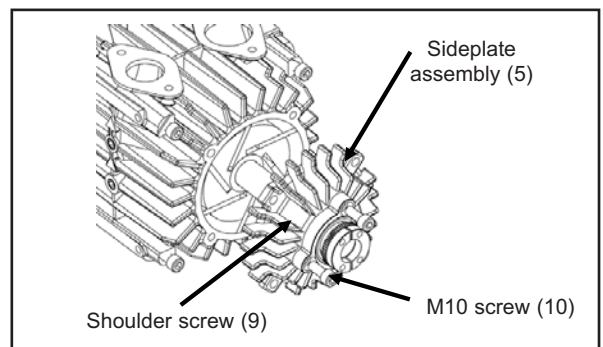

Figure 13

6. Carefully slide the sideplate assembly (5) from the shaft. USE CARE not to damage any of the machined surfaces of the shaft, body or sideplate when removing.
7. Once the sideplate assembly is removed, support the weight of the rotor with a block of wood to keep it from damaging the opposite bearing and seals.

## 5. MAINTENANCE (continued)

### 5.4 Blade removal and inspection

1. Thoroughly clean end of machine to be dismantled. Care must be taken during inspection that no dirt, oil or grease enters the machine.
2. Follow Steps 1 through 7 under the § "SIDEPLATE REMOVAL".

#### NOTICE :

**HANDLE BLADES BY EDGES ONLY.**

3. Remove blades (3) for inspection.



**BLADES MAY STILL HOT AFTER USE.**

Blades must be replaced if chipped or if the height of the blade has worn below 1.57" (40 mm) ; See figure 9.

4. Check blades for the following conditions and refer to the § "TROUBLESHOOTING" for information on causes.
  - Chipped blade tips.
  - Heavy wear on the ends (this is more visible on the sideplates).
  - Scoring on the blades.
  - Grease or oil contamination.
5. Whenever there has been compressor failure involving blade breakage perform the following :
  - Ensure blade debris is completely removed before installing new set of blades. Thoroughly clean inlet piping and filter. Replace the inlet air filter.
  - Refer to the § "TROUBLESHOOTING" to determine cause of blade failure and correct problem.
  - Check the compressor body and rotor for damage.
  - Ensure valves are set correctly, and all inlet and discharge piping is drained and cleaned.

#### NOTICE :

**BLADE BREAKAGE REQUIRES THAT AIR FILTER BE CLEANED OR REPLACED, SUCTION AND DISCHARGE PIPING BE CLEANED, AND RELIEF/ CHECK VALVES INSPECTED OR REPLACED.**

6. When replacing blades, make sure they are inserted into the rotor slots in the correct position as shown in Figure 14. The angle of the blade tip must match the arrows on the body bore.

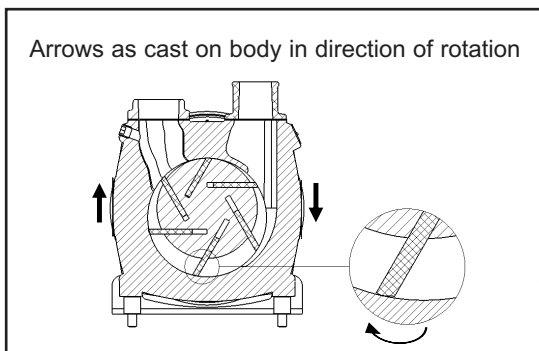

Figure 14

7. Reassemble compressor in reverse order to dismantling. All internal surfaces of body, rotor, blades and sideplates must be free of oil or grease. When reassembling, replace all O-rings that have been removed during service with new.

### 5.5 Rotor inspection

1. After removal of both sideplate assemblies, carefully remove the rotor from the compressor body, ensuring the shaft keyway does not damage plating or score the body ; See figure 15.

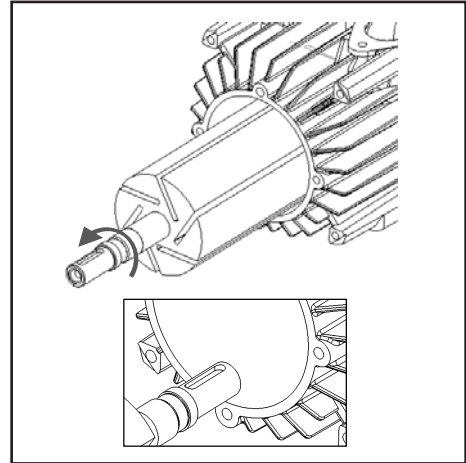

Figure 15

#### NOTICE :

**ROTOR IS HEAVY. LIFTING EQUIPMENT IS RECOMMENDED WHEN HANDLING ROTOR.**

2. Once the rotor is removed, rest it in a secure place where it can not roll away and become damaged.
3. Clean the rotor thoroughly. Check the rotor slots for wear, damage or burrs. Blades must slide freely in the slots.

## 5. MAINTENANCE (continued)

### 5.6 Sideplate disassembly

1. Remove the three M10 screws (11) securing the bearing cap, and remove the bearing cap (2) ; See figure 16.

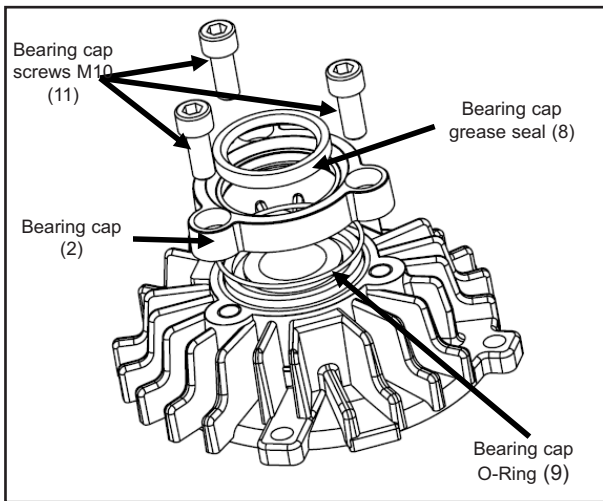

Figure 16

2. Remove the bearing cap O-ring (9) and tap out bearing cap grease seal (8).

#### IMPORTANT :

Ensure that any bearing cap shims remain with the sideplate components. Do not mix them up with the components from any other sideplate.

3. Slide bearing (7) from sideplate. The bearing is a slip fit.
4. Remove distance sleeve (3) and tap out grease seal (6) from sideplate. Remove circlip (5) ; See figure 17.

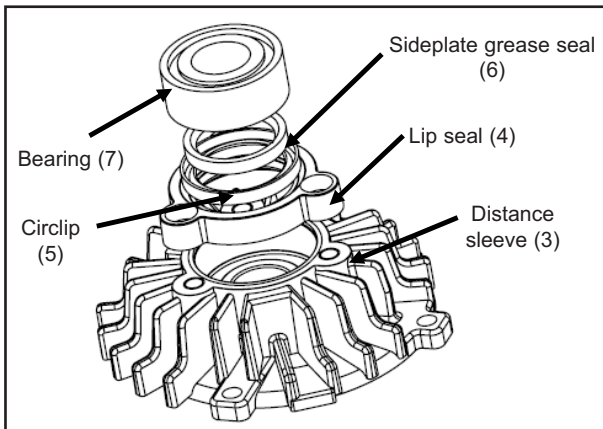

Figure 17

5. Tap out lip seal (4) using a drift. USE CARE not to damage sideplate when removing seals.
6. Thoroughly clean sideplate and bearings. If either sideplate or bearings show any damage or wear, they must be replaced or serviced. Slight damage or scoring to the sideplate may be carefully filed off.

### 5.7 Sideplate assembly

1. Before starting, place the sideplate (1) face down on a flat, clean surface. Take care not to scratch or damage the sideplate.
2. Using a properly sized seal punch, tap in a new wiper seal with the lip down, facing the rotor, to the full depth of the recess ; See figure 18.

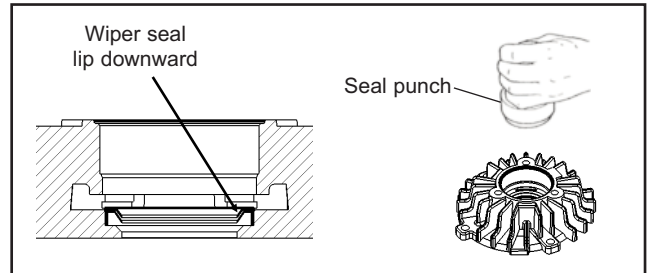

Figure 18

3. Using a circlip pliers, install the circlip (5) into the sideplate ; See figure 19.

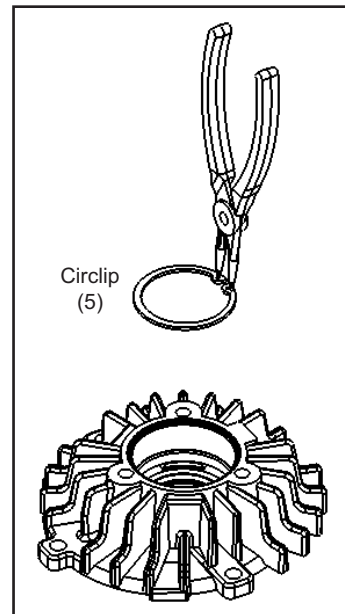

Figure 19

4. Lightly grease a new sideplate oil seal (6). Using a properly sized seal punch, insert into bearing recess with lip up, facing the bearing. Ensure the seal is flush with the bottom of the recess ; See figure 20.

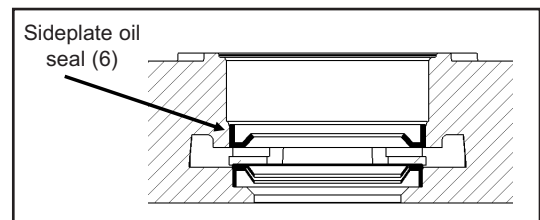
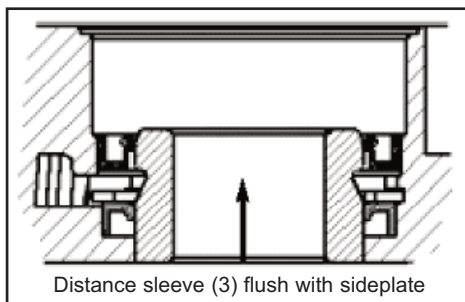

Figure 20

## 5. MAINTENANCE (continued)

- From the rotor side, push in the distance sleeve (3), through both seals, until it is flush with the face of the sideplate ; See figure 21.



- Lightly grease a new bearing cap oil seal (8). Using a properly sized seal punch, install the oil seal into the bearing cap with the lip up, so that it will face the bearing ; See figure 22.

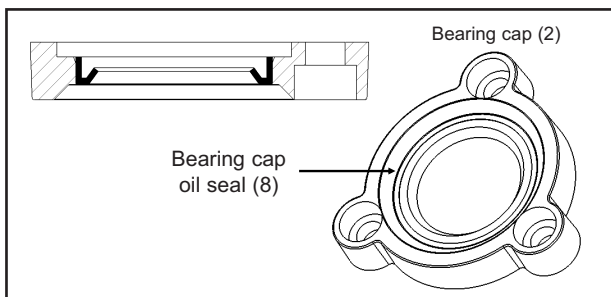

Figure 22

- Pack the bearing with Mobil SHC Polyrex™ 462 grease, or equivalent, and insert into sideplate.
- Install a new bearing cap O-ring, plus any shims, and attach the bearing cap to the sideplate with three M10 capscrews (11). Tighten the capscrews to 26 lbs ft (35 N.m) ; See figure 23.

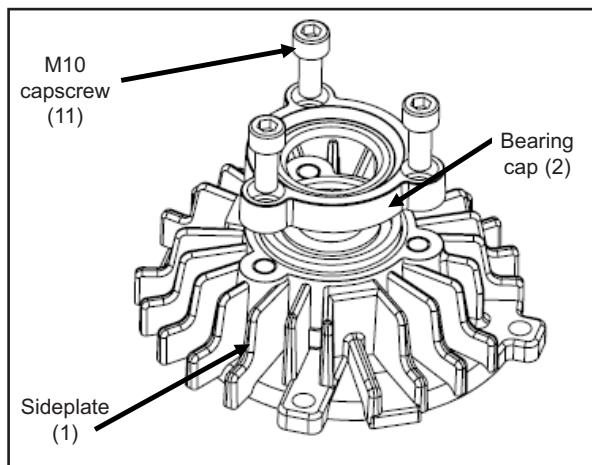

Figure 23

### 5.8 Setting sideplate clearance

- Prior to attaching the sideplate to the compressor body, check the end clearance between the rotor and sideplate using two feeler gauge strips. Ensure the rotor is seated in the sideplate. Use a rubber mallet to tap on free end if necessary.
- With a feeler gauge on each side of the rotor shaft, as shown on Figure 24, check the clearance.

Allowable Clearance :  
0.004" to 0.005" (0.100 mm to 0.125 mm)

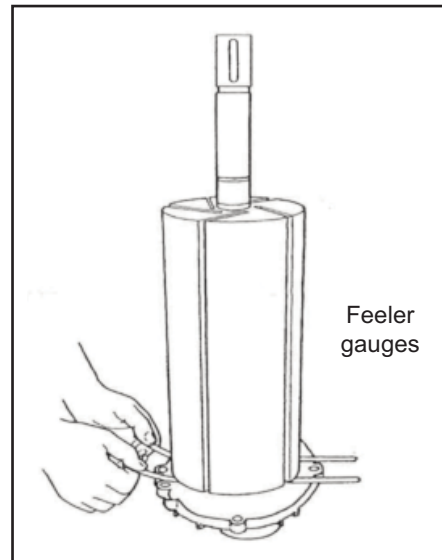

Figure 24

- The sideplate clearance can be adjusted by changing the thickness of the bearing cap shim used.
- Mark each sideplate "CW" (clockwise) or "CCW" (Counterclockwise) to identify which end of the rotor the clearances were set to.

#### NOTICE :

**BE SURE TO MATCH THE CORRECT SIDEPLATE WITH THE CORRECT END OF THE ROTOR.**



## 5. MAINTENANCE (continued)

### 5.9 Compressor assembly

1. Stand the compressor body, ports down, on "V" blocks or packing as shown in Figure 25. Use care during the assembly process to avoid any contamination. All internal surfaces of the body, rotor, blades and sideplates **MUST** be free of all debris or grease.

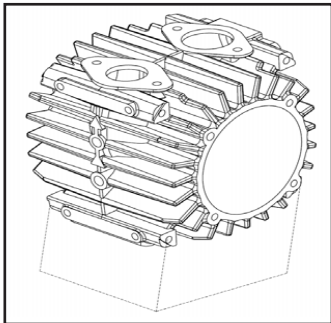

Figure 25

2. With the new sideplate O-ring installed, attach the clockwise (CW) sideplate to the clockwise (CW) end of the body. Ensure the sideplate surface is free of all grease. Install three M10 capscrews (7), torquing to 26 lbs ft (35 N.m) and one M8 shoulder screw (9), torquing to 7 lbs ft (10 N.m).
3. Slide the correct end of the rotor into the body, being careful to keep all components clean and to avoid damaging the plating on the rotor and body.

**IMPORTANT :**

Match arrows on rotor with arrows on compressor body. If the arrows do not match rotation, the sideplate or rotor must be changed to match ; See figure 26.

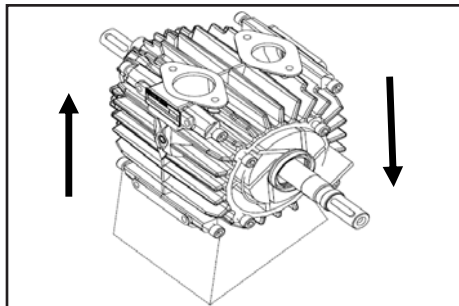
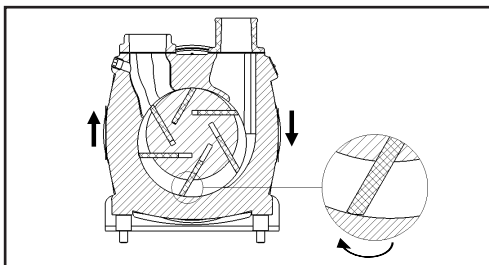

Figure 26

4. With blades and hands free from oil or grease, slide blades into rotor slots, ensuring that the angle of the blade tip matches the arrow cast on body bore, as shown below.



5. Install second sideplate assembly as instructed in step 2 above. See figure 27.

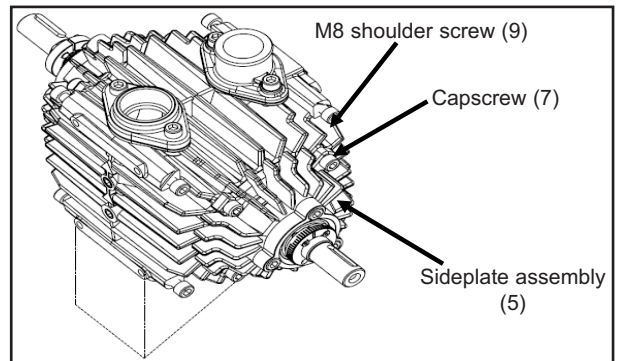

Figure 27

6. Attach the fans (11) and split sleeves (4) with the M8 set screws (10) coated with Loctite® \* 243. Torque the set screws to 11 lbs ft (15 N.m). See figure 28.

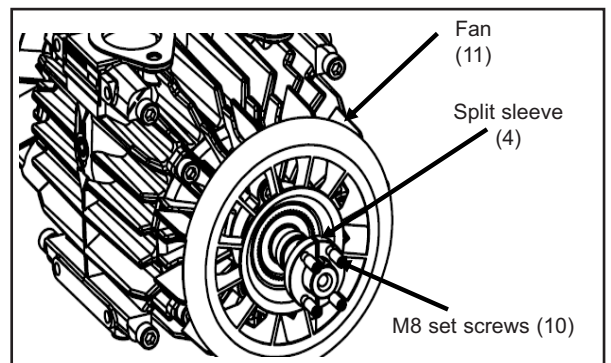

Figure 28

7. Install both cowls (12 and 13) over the fans with the M10 cowl screws (8). Torque cowl screws to 26 lbs ft (35 N.m). See figure 29.

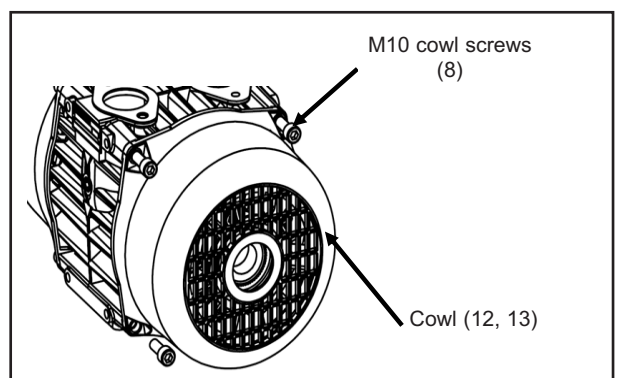

Figure 29

\* Loctite® is a registered trademark.

## 5. MAINTENANCE (continued)

### 5.10 Initial start up / Reinstallation

**NOTICE :**

**FOLLOW ALL HAZARD WARNINGS AND NOTICES IN THE § "SAFETY DATA" AND "MAINTENANCE" OF THIS MANUAL.**

1. When re-installing compressor, check for the following :
  - Correct compressor rotation with respect to the drive.
  - Correct orientation of compressor with respect to the piping.
  - Correct coupling alignment.
  - Noise due to rubbing fans or guards, etc.
2. Install a pressure gauge to the discharge port of the compressor.
3. Run compressor by following steps under the § "USE - Starting-Up" of this manual.

**NOTE :**

**DO NOT CLOSE THE VENT VALVE YET.**

4. After start-up, verify the following :
  - Check compressor speed. Compressor speed must fall within the operating parameters indicated in the § "TECHNICAL DATA".
  - Re-check to verify correct compressor rotation.
5. Perform a Pressure Test :
  - Isolate the piping from the tank by closing off the trailer isolation valve.
  - Slowly close the vent valve and observe the pressure reading on the gauge installed on the compressor. The pressure must not exceed 40 psi (2,75 bar).
  - After recording the gauge reading, open the vent valve.

## 6. TROUBLESHOOTING

**NOTICE :**

**FOLLOW ALL HAZARD WARNINGS AND NOTICES IN THE § "SAFETY DATA" AND "MAINTENANCE" OF THIS MANUAL.**

PROBLEM	CAUSE
<b>Blades sticking</b> See causes 1 through 3	1. Debris or contamination in compressor. 2. Rotor slot damage. 3. Worn or damaged blades. 4. Incorrect operating speed. 5. Incorrect rotation. 6. Ridged bore in compressor body. 7. Operating speed too slow. 8. Operating speed too fast. 9. Cooling fins/cowl vents clogged. 10. Driver misalignment. 11. Incorrect fan installation. 12. Air filter plugged or restricted inlet piping. 13. Fan cowls installed incorrectly / insufficient clearance around cowls. 14. Inlet filter hose damaged. 15. Debris or contamination in inlet piping and /or filter.
<b>Broken or chipped blades</b> See causes 1, 4, 5, 7, 8, 14, 15	
<b>Excessive noise</b> See causes 3, 6, 7, 10, 11	
<b>Overheating</b> See causes 1, 2, 3, 8 through 13, 15	

## 7. SCRAPPING

The compressor must be scrapped in compliance with the regulations in force.

During this operation, particular care must be paid to the drainage stages of the compressor.

## 8. COMPRESSORS FORM INFORMATION

Before any material return, it is required to get an authorization from MOUVEX.

	<h3>COMPRESSORS FORM INFORMATION</h3>	
MOUVEX After Sales Department Z.I. de la Plaine des Isles 89000 AUXERRE	Tel : (33) 3 86 49 86 03 Fax : (33) 3 86 49 86 48	Date : Contact : File :
<b>For proper treatment of equipment return, please complete this information form.</b>		
<b>A - User's/customer's name and address</b>		
Person to be contacted for this job :		Telephone :
<b>B - Installer's name and address</b>		
Person to be contacted for this job :		Telephone :
<b>C - Machine N°</b>	<b>D - Start-up date</b>	
<input type="checkbox"/> Estimated number of operating hours : _____		
<b>E - Type of installation</b>	<b>F - Working conditions</b>	
<input type="checkbox"/> Transfert <input type="checkbox"/> Other <input type="checkbox"/> Short description           <input type="checkbox"/> Join if possible a plan of the installation or a photo	<input type="checkbox"/> Speed <input type="checkbox"/> Discharge pressure           <input type="checkbox"/> Material transferred	
<b>G - Discrepancy description</b>		
<input type="checkbox"/> Jamming <input type="checkbox"/> Leak <input type="checkbox"/> Insufficient flow <input type="checkbox"/> Insufficient pressure <input type="checkbox"/> Noise, vibration		
<b>H - Has the machine been replaced by a new one? If so, give the machine N° :</b>		
<b>I - User's remarks and comments concerning the discrepancy :</b>		
<b>Please send us back this document duly completed by fax or e-mail as soon as possible.</b>		