

# ***DMX 3 - DMX 3 MF***



***INSTALLATION***

***OPERATION***

***MAINTENANCE***

**INSTALLATION :**

- DMX overall dimensions	3
- Selective valve overall dimensions	3
- SBL MF valve overall dimensions	4
- Characteristics to comply with	5
- List of counters that can be fitted to the unit	6
- DMX 3 external pneumatic diagram	7
- DMX 3 MF external pneumatic diagram, with manual valve	8
- DMX 3 MF external pneumatic diagram, with pneumatic valve	9
- DMX (alone) sealing	10
- DMX (with manual valve) sealing	11
- DMX (with pneumatic valve) sealing	12
- Wording to stamp on the measurement unit plate	13

**USE :**

- Schematic diagram	14
- SBL MF valve use	15
- Measurement compartment discharge	16
- Recovery not measured	17
- Use of the pump as a transfer pump	18
- Use as flow detector	19

**EXPLODED VIEW :**

- DMX	20
- Complete Dry valve	21
- DMX Cover	22

**MALFUNCTIONING :**

- Causes and remedies	23
-----------------------	----

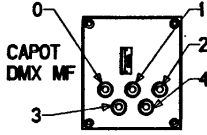
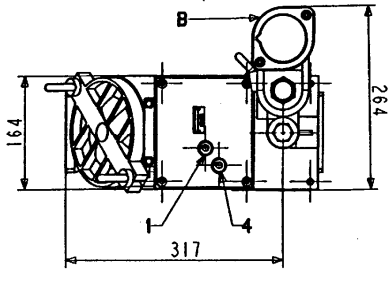
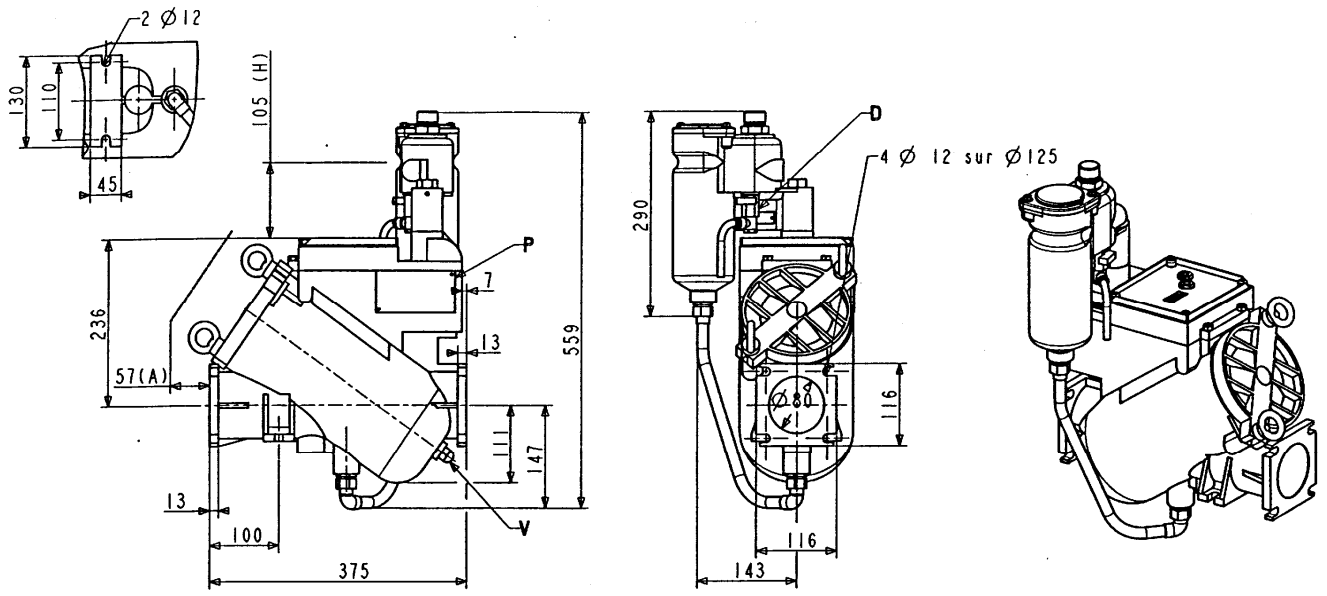

0	Breather	Tube 4x6
5	Stop valve control	Tube 4x6
4	Bypass output	Tube 4x6
3	Free distribution signal	Tube 4x6
2	3-bar air supply	Tube 4x6
1	5.5-bar air supply	Tube 4x6
V	Filter emptying/attachment	
P	Identification plate	
H	Cover clearance	
D	Bleed valve	Tube 8x10
B	Dry valve	
A	Basket clearance	

A	Compressed air supply port	G 1/4
B	Predetermination variant	G 1/8
C	Breather (connected to hose Ø 4x6 minimum, directed downwards)	G 1/8 M5
D	Drip strip	

**COMPENSATED SELECTIVE VALVE**

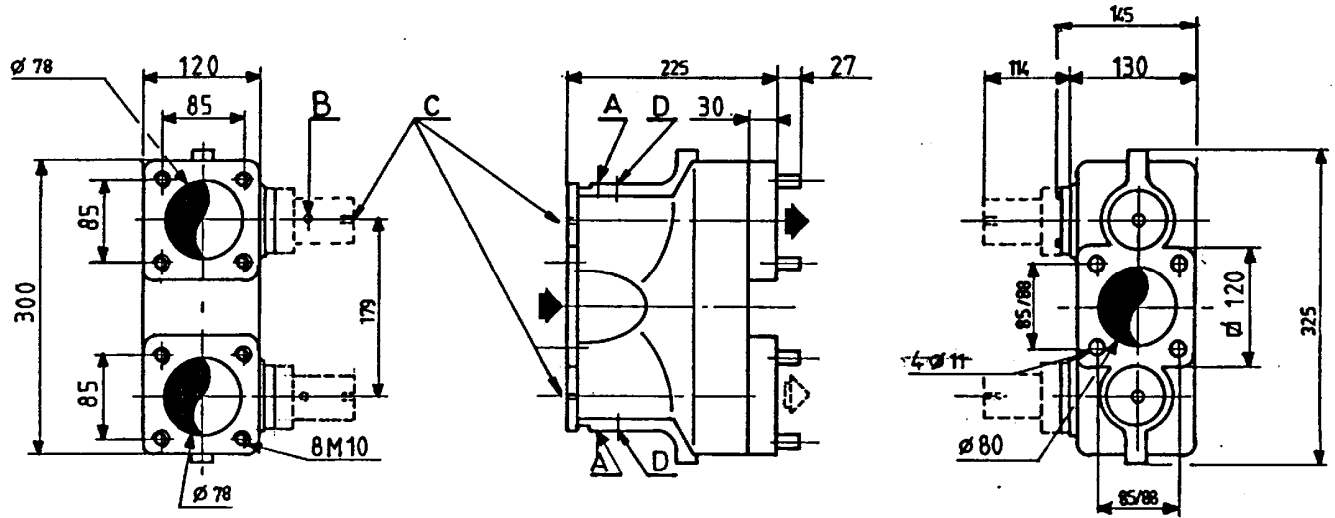

Note: Make sure to direct pneumatic supply port B of the predetermination valve towards the selective valve product output side.

OVERALL DIMENSIONS DMX 3 MF - mm

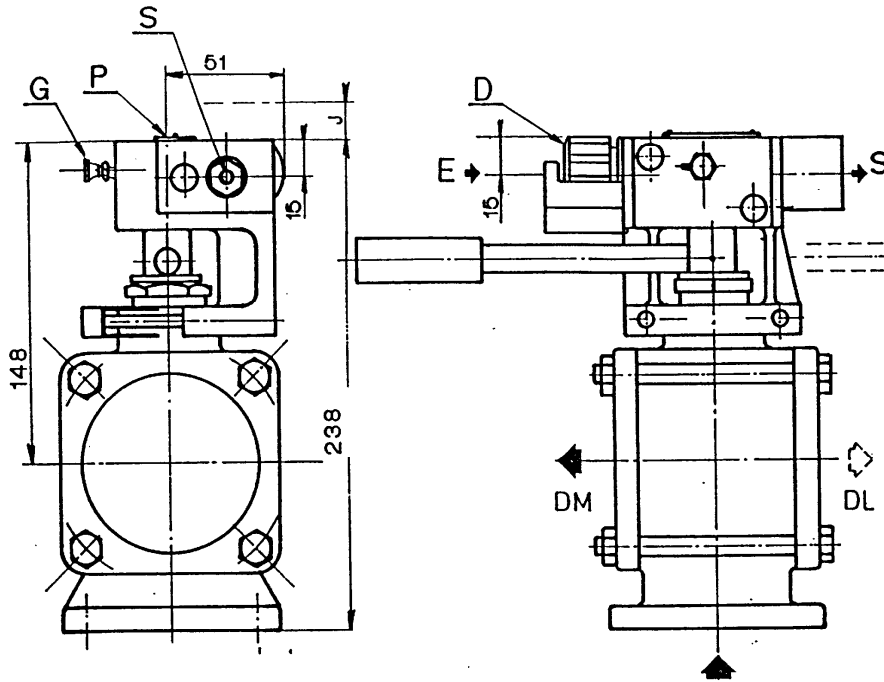

**IMPORTANT**  
 The directions DM and DL must be adhered to.  
 To ensure correct draining, never have the outlet DL pointing upward

- D Valve exhaust plug
- E Compressed air inlet orifice = G 1/8
- G Lubricator
- J Release for disassembly (J=25) (J1=20)
- P Identification plate
- S Compressed air utilisation orifice (tube 4x6)

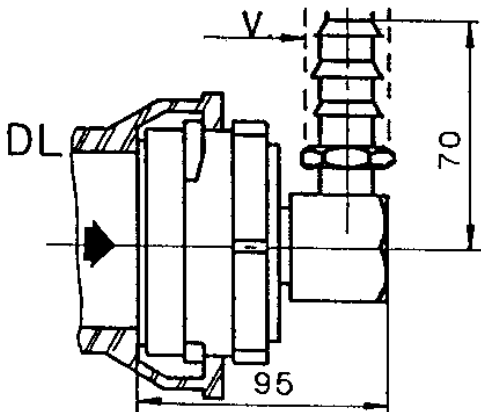
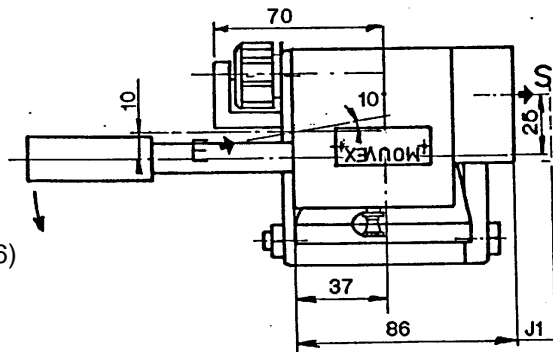

The connection of the automatic draining plug (BVA) outlet is to be made with  $\frac{3}{4}$  " diam. Welded tube held by a collar without the need for a gradient.

There are two possible connections :  
 - return at the top of a compartment  
 - return to a separate tank

**CHARACTERISTICS TO COMPLY WITH**

MF version	Use of a 3-way valve before an SBL MF type manual control counter or selective type pneumatic counter.				
Installation	Port centerlines horizontal, pneumatic connections directed upwards.				
Supply	Under load (gravity supply). The connection pipe from the compartment must be at a $\geq 3\%$ slope continuously downwards slope $\geq 3\%$ . The vacuum generated by the maximum use rate shall not exceed 0.150 bar;				
Connection	Flanged directly to the pump suction circuit. Otherwise, schedule : - Distance $\leq 0.5$ m : horizontal connection pipe - Distance $>0.5$ m : connection pipe with a down slope to the pump $\geq 5\%$ .				
Temperature range	-20°C to +70°C				
Maximum hydraulic pressure in the DMX	3 bar				
Maximum pneumatic pressure in the DMX	5.5 bar				
Pneumatic supply	One lubricator filter must be used. Minimum pressure: 5.5 bar.				
Minimum delivery	200 l				
Maximum flow rate	66 m <sup>3</sup> /h				
Measurable fluids	Ordinary petrol, 5-star petrol, diesel fuel, domestic fuel oil, kerosene, etc.				
Hydraulic pressure constraints	Flow rate m <sup>3</sup> /h	30	40	50	66
	Valve calibration (bar)	0.3	1.4	1.4	1.4
	Minimum operating pressure (bar)	1.4	1.9	2.2	2.6
Approval validity	- European with mechanical counter used - French only with electronic counter used				
Filtration capacity	Bottom basket : 1,300 microns Top basket : 400 microns				

## LIST OF COUNTERS THAT CAN BE FITTED TO THE UNIT

### MECHANICAL COUNTERS

MANUFACTURER	MODEL	MINIMUM FLOW RATE (m <sup>3</sup> /h)	MAXIMUM FLOW RATE (m <sup>3</sup> /h)	MAXIMUM PRESSURE (bar)	APPROVAL CERTIFICATES
LIQUID CONTROL	M7	2.7	27	10.5	UK81 1782 STD 3994, dated July 19, 1991
LIQUID CONTROL	M15	5.4	54	10.5	UK81 1782 STD 3994 dated July 19, 1991
LIQUID CONTROL	M25	6.6	66	10.5	UK81 1782 std 3994 dated July 19, 1991
SATAM	ZC17.24.24	2.4	24	8	F95.00.422.002.0 dated July 12, 1995
SATAM	ZC17.24.48	4.8	48	6	F95.00.422.002.0 dated July 12, 1995
OIL METER	SBM 75	3	30	20	D81 //5.243.19 dated September 25, 1991
OIL METER	SBM 150	6	60	10	D79 5.243.01 dated February 2, 1989
PERNIN	NVR 20	2	20	8	F96.00.422.002.0 dated September 11, 1996
PERNIN	NVR 45	4.5	45	8	F96.00.422.002.0 dated September 11, 1996
PERNIN	NVR 80	8	80	8	F96.00.422.002.0 dated September 11, 1996

### ELECTRONIC COUNTERS

LIQUID CONTROL measurement chambers M7, M15 or M25 (cited above) associated with the electronic indicator and calculating device, according to decision No. 99.00.422.004.1 dated June 4, 1999

## EXTERNAL PNEUMATIC DIAGRAMS

### DMX 3 EXTERNAL PNEUMATIC DIAGRAM

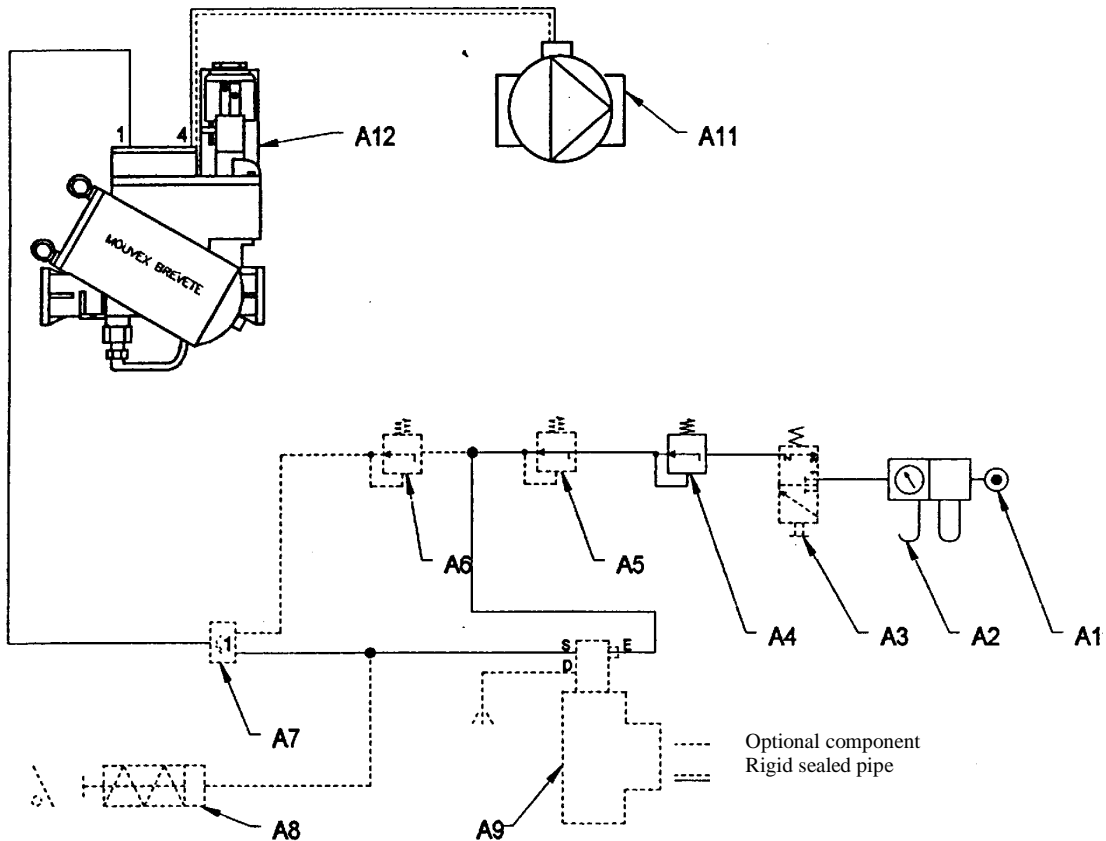

- A1 - P>6 bar connected as bypass on movement takeoff
- A2 - Lubricator filter
- A3 - Emergency stop
- A4 - 5.5-bar pressure regulator
- A5 - Flow regulator
- A6 - 3-bar pressure regulator
- A7 - "or" cell
- A8 - Motor acceleration cylinder
- A9 - Flow rate detector
- A11 - CC8 pump with pneumatic bypass, not spring-loaded
- A12 - DMX 3

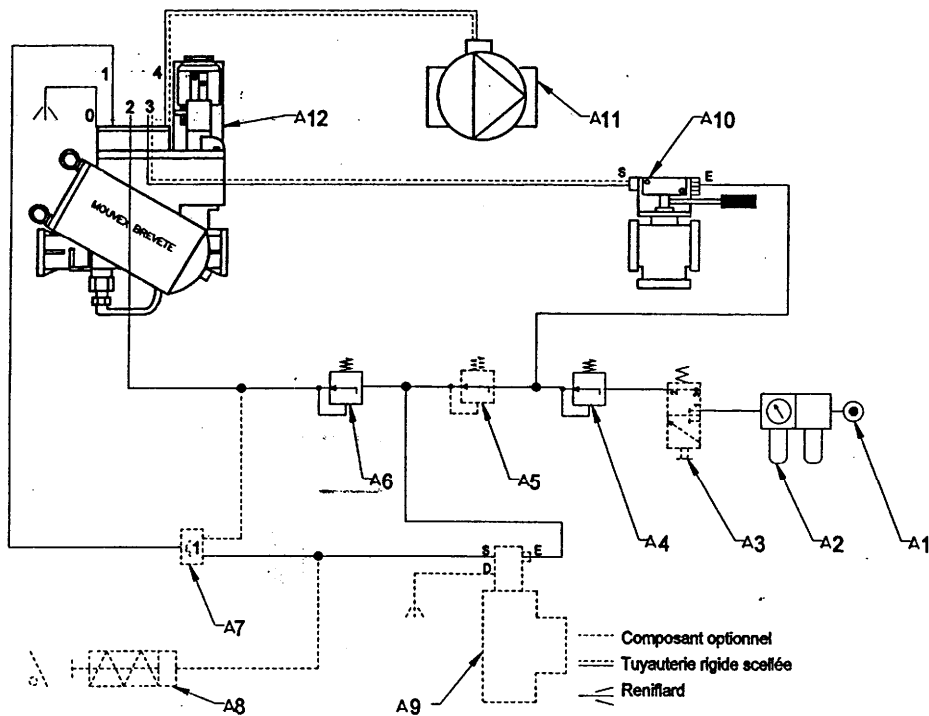

- A1 - P>6 bar connected as bypass on movement takeoff
- A2 - Lubricator filter
- A3 - Emergency stop
- A4 - 5.5-bar pressure regulator
- A5 - Flow regulator
- A6 - 3-bar pressure regulator
- A7 - "or" cell
- A8 - Motor acceleration cylinder
- A9 - Flow rate detector
- A10 - SBL MF manual FD valve
- A11 - CC8 pump with pneumatic bypass, not spring-loaded
- A12 - DMX 3 MF



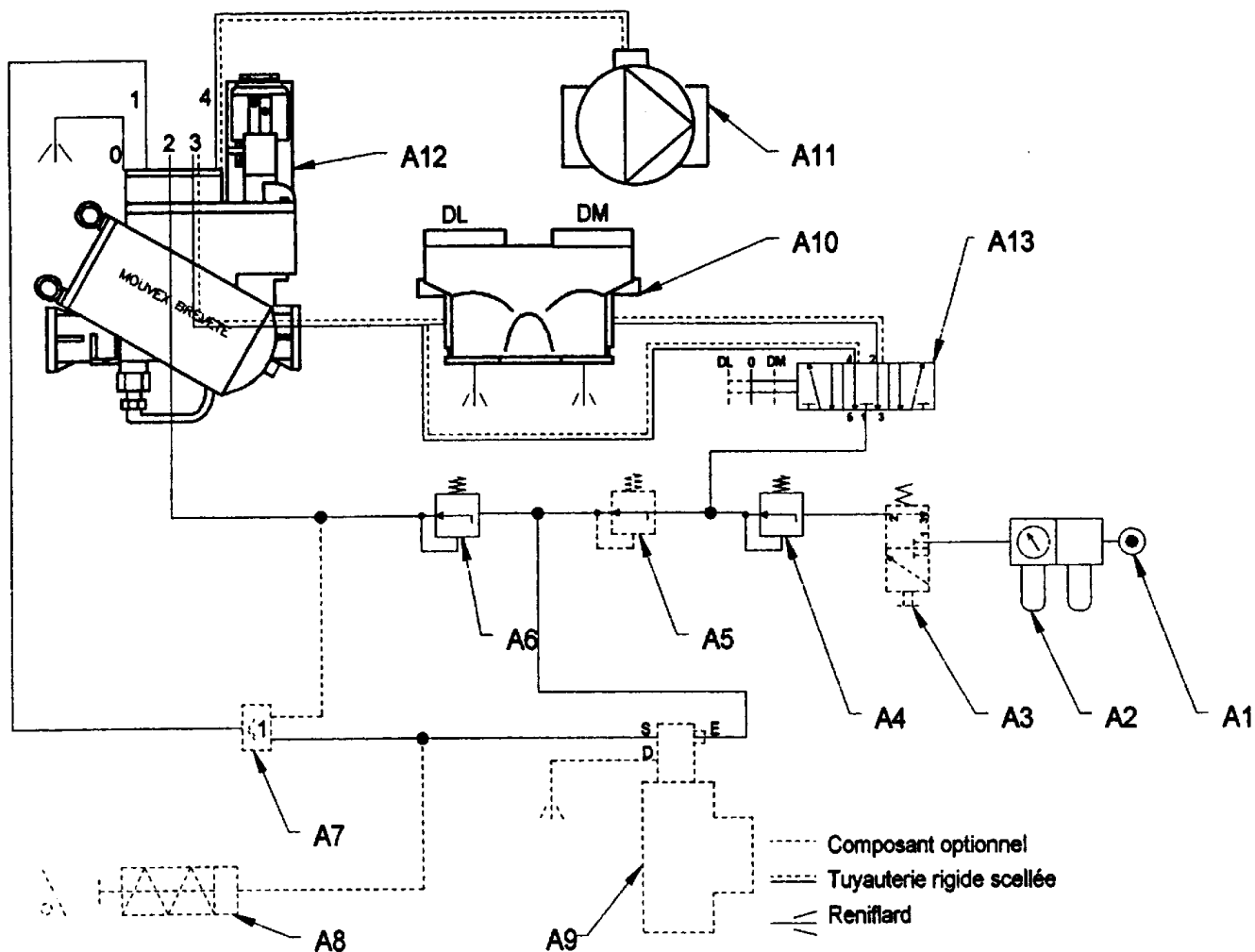

- A1 - P>6 bar connected as bypass on movement takeoff
- A2 - Lubricator filter
- A3 - Emergency stop
- A4 - 5.5-bar pressure regulator
- A5 - Flow regulator
- A6 - 3-bar pressure regulator
- A7 - "or" cell
- A8 - Motor acceleration cylinder
- A9 - Flow rate detector
- A10 - Selective pneumatic valve
- A12 - DMX 3 MF
- A13 - 5/3 distributor with 3 and 5 exhausts sealed, prohibiting any blanking

# DMX 3 SEALING

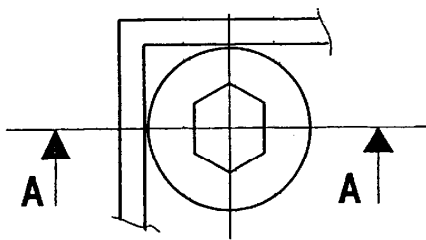
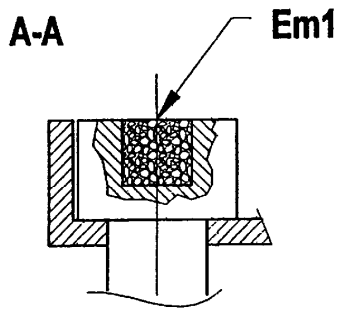

LAYOUT Em1 (scale 2.5)

LAYOUT Em2 (scale 1)

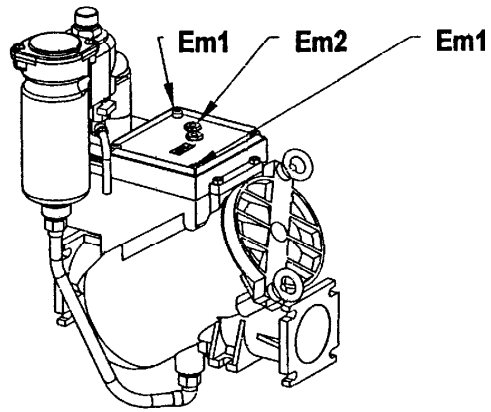
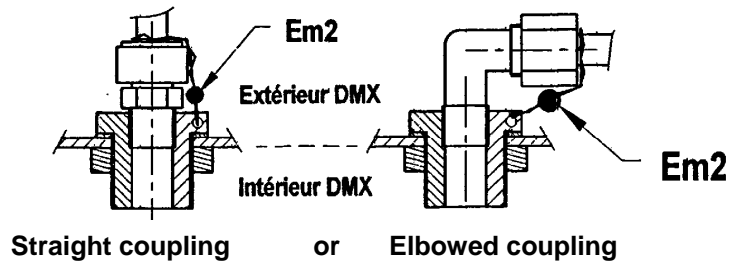

62971A

# SEALING WITH MANUAL VALVE

## OPERATION OF DMX 3 MF WITH FREE DISTRIBUTION AND MANUAL VALVE

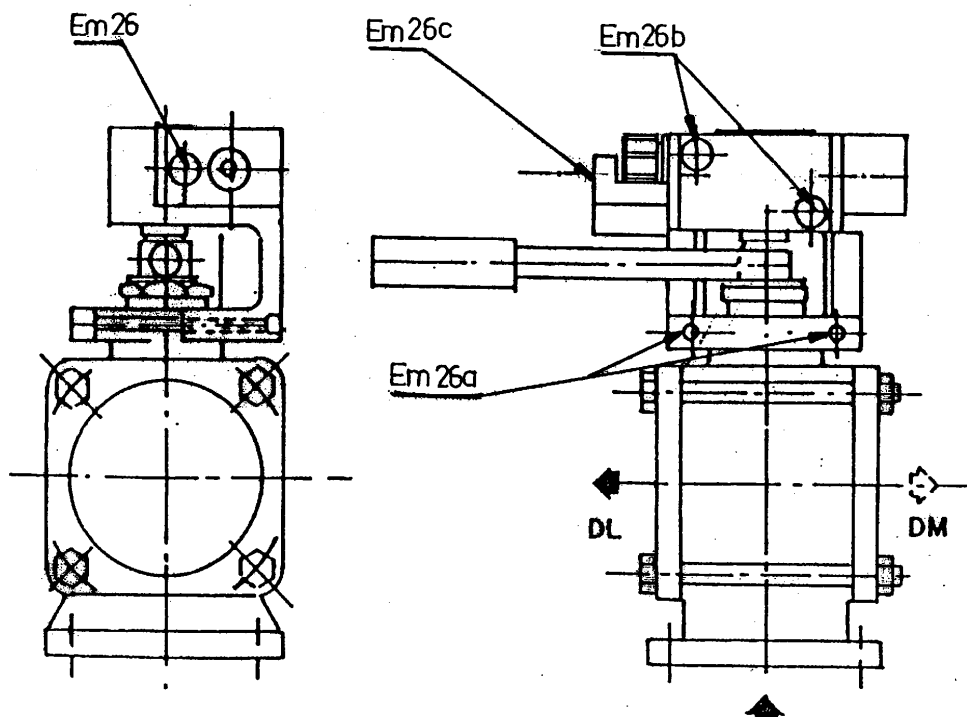
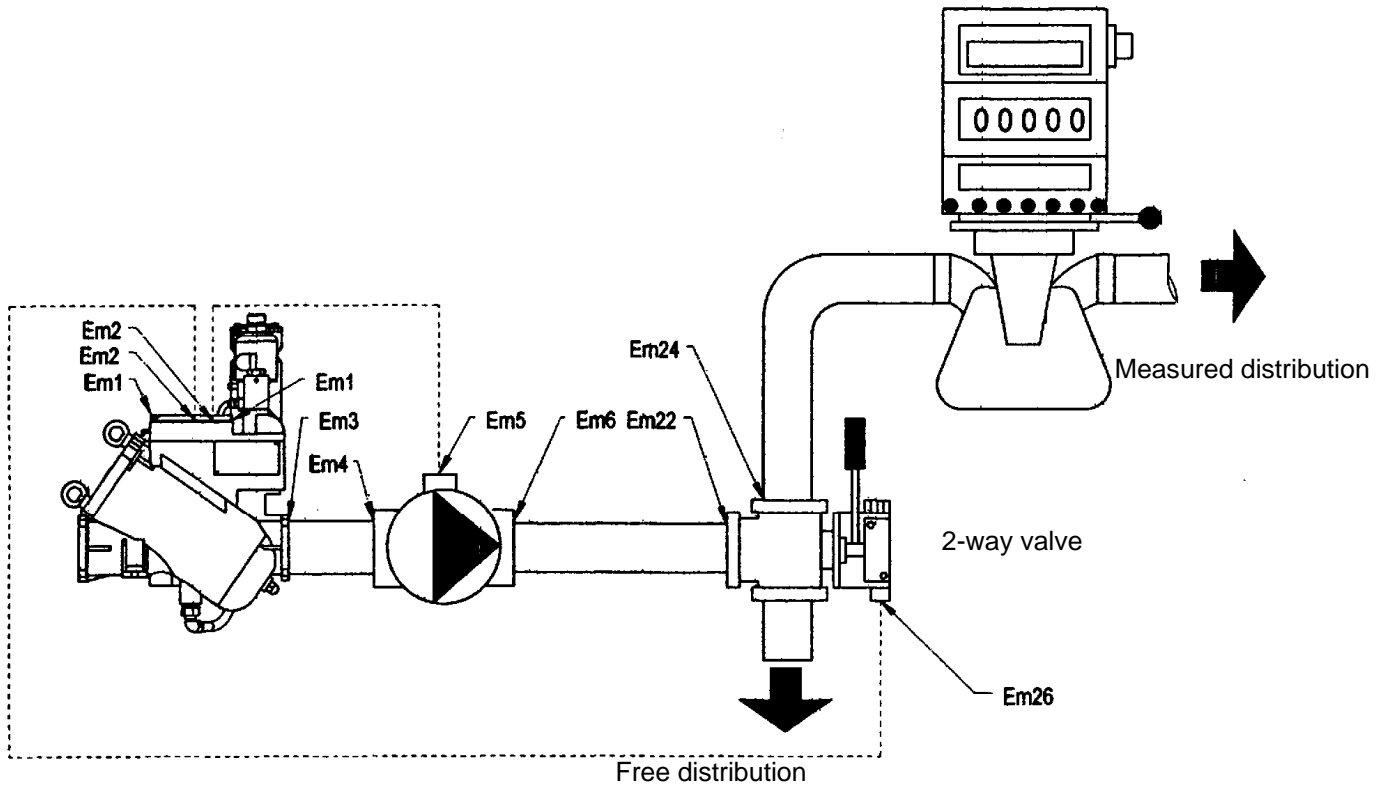

SEALING WITH PNEUMATIC VALVE

OPERATION OF DMX 3 MF  
WITH FREE DISTRIBUTION AND PNEUMATIC VALVE

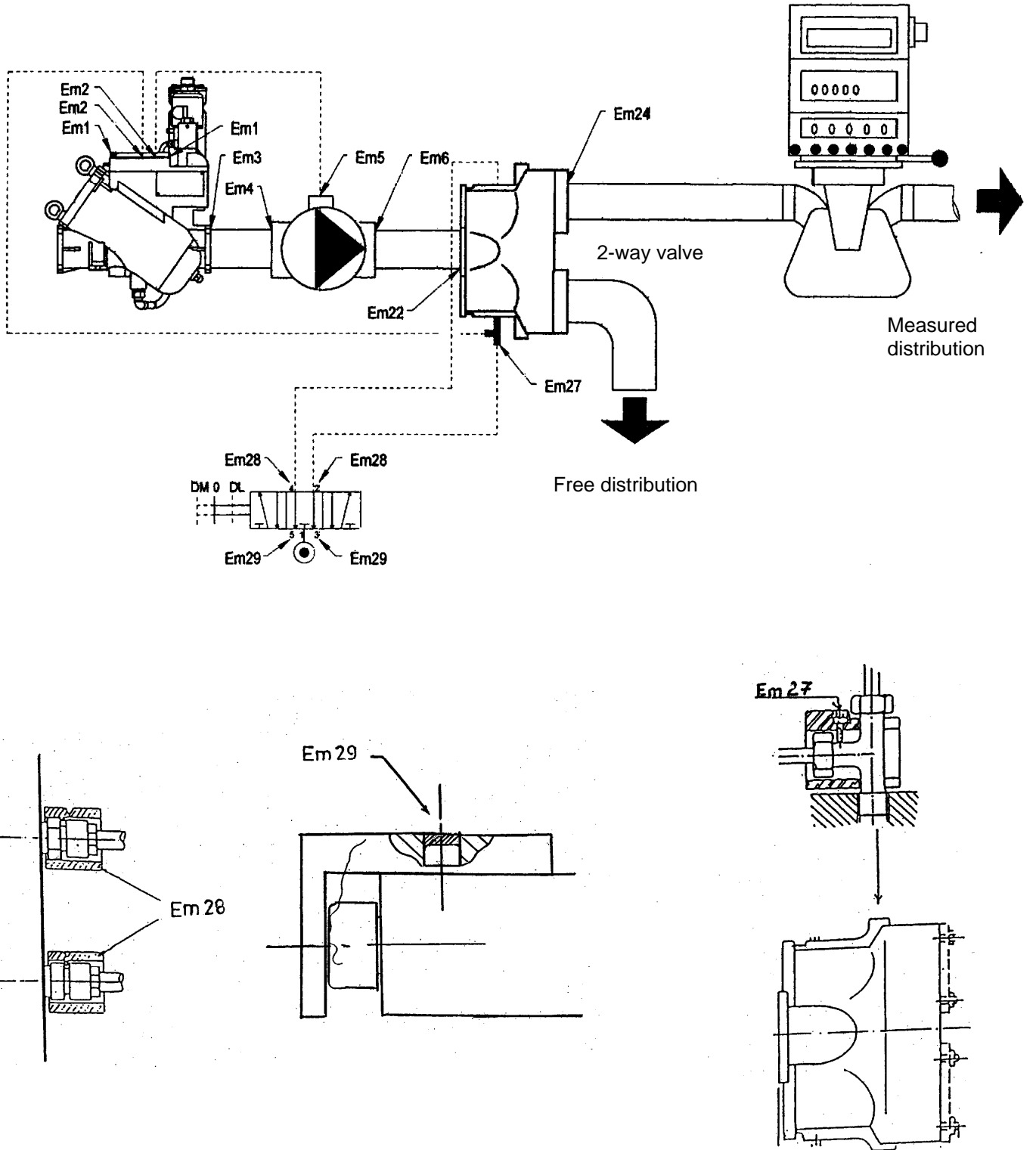

**WORDING TO STAMP ON THE MEASUREMENT UNIT PLATE (supplied blank)**

**MEASUREMENT UNIT**  
**MOUVEX**  
Z.I. Plaine des Isles - 89000 AUXERRE - FRANCE

**INSTALLER**

model or drawing   Assembly No.

Measured fluids  Year

Maximum flow rate  m<sup>3</sup>/h Max. pressure  bar

Minimum flow rate  m<sup>3</sup>/h Min. pressure  bar

Stamps

x156

- |                              |   |                                   |                           |   |                   |
|------------------------------|---|-----------------------------------|---------------------------|---|-------------------|
| For<br>mechanical<br>counter | { | A : Name of the installer         | For electronic<br>counter | { | B2: "F99462013"   |
|                              |   | B1 : "E DMX 3" or "E DMX 3 MF"    |                           |   | C: Not applicable |
|                              |   | B2 : Not applicable               |                           |   | D: Not applicable |
|                              |   | C : "F99"                         |                           |   |                   |
|                              |   | D : "462012"                      |                           |   |                   |
|                              |   | E : Serial No.                    |                           |   |                   |
|                              |   | F : "Minimum delivery 200 liters" |                           |   |                   |
|                              |   | G : Measured product              |                           |   |                   |
| H : Year                     |   |                                   |                           |   |                   |

i	30	40	50	66
J	Minimum permissible flow rate per counter			
K	Maximum permissible flow rate per counter			
L	0.3	1.4	1.4	1.4

## OPERATION

Your delivery system is equipped with a gas separator DMX 3 MF in combination with a pump CC8 with pneumatic bypass.

This allows you to carry out distribution and measurement of a product (DF0 -Domestic Fuel Oil in most cases for the DMX 3 MF).

The DMX 3 MF do not require any specific operation, all that is needed is to link the hose 17 to the compartment drained, to open the compartment valve and to start the pump. The measured distribution can begin.

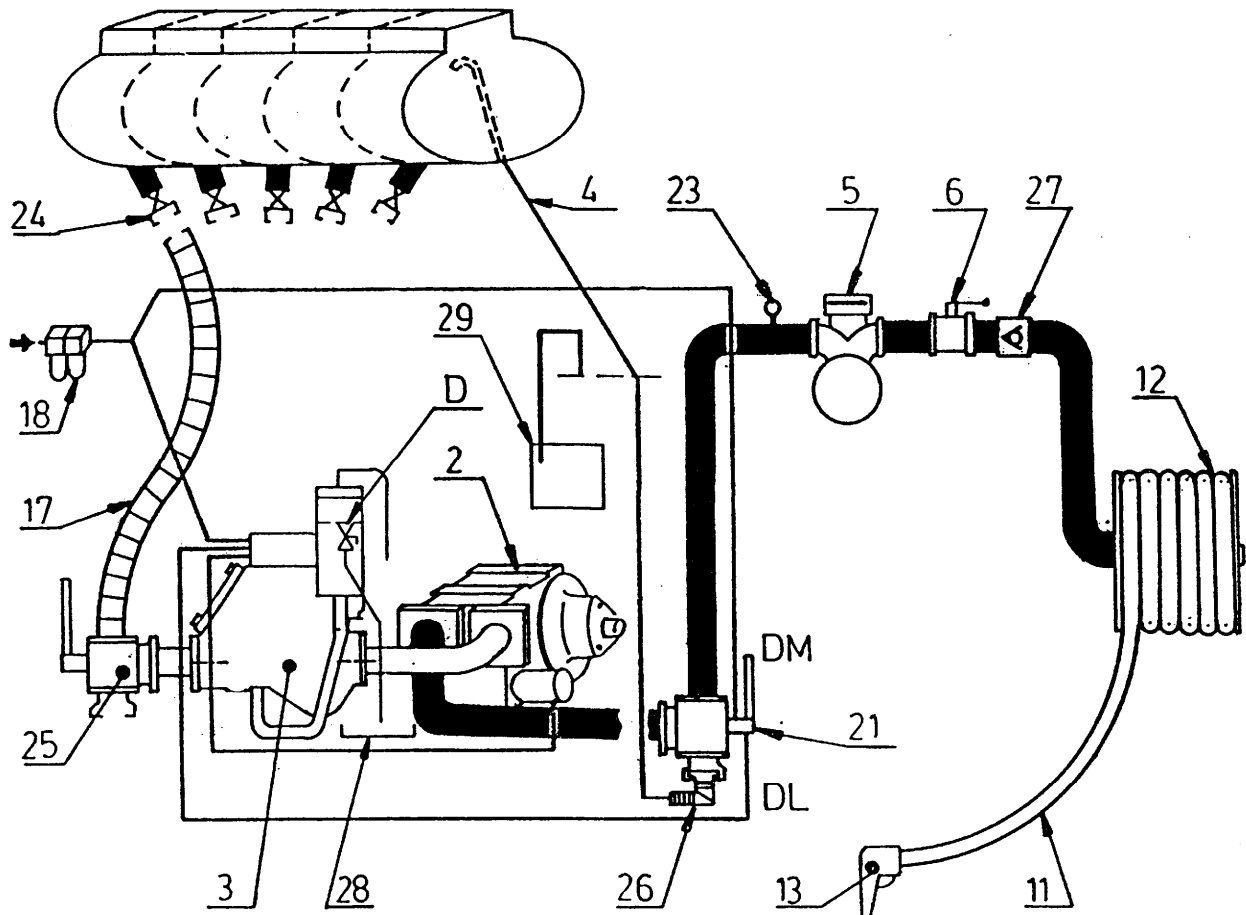

- |   |  |
|---|--|
| 2 Vane pump CC8 with non-spring loaded pneumatic bypass | 21 3-way valve type SBL-MF allowing operation in measured distribution (MD) or in free draining (FD) |
| 3 Gas separator DMX 3 MF                                | 23 Pressure gauge  |
| 4 Degassing circuit connected to a tank                 | 24 Drain valve   |
| 5 Counter   | 25 3-way valve type SBL  |
| 6 Manual stop valve                                     | 26 Automatic draining valve  |
| 11 Plain hose on hosereel for measured distribution     | 27 Check valve (not necessary when equipped with flow detector)                                      |
| 12 Hosereel   | 28 Drip tray   |
| 13 Gradual closing type nozzle                          | 29 Draining tank   |
| 17 Suction pipping or hose                              |  |
| 18 Filter-Lubricator assembly                           |  |

## MEASURED DISTRIBUTION, SBL-MF valve in DM position

The DMX 3 MF does not require any specific operation, all that is needed is to link the hose 17 to the compartment to be drained, to open the compartment valve and to start the pump. The measured distribution can begin.

## Other functions, SBL-MF valve in FD position

Before moving to another functioning mode, drain the installation between the valves 24 and 21 in order to avoid product mixes and product loss.

To drain :

- ⇒ make sure that the installation includes an automatic draining plug (ADP) well locked
- ⇒ make sure that the foam return compartment (or drainage tank), can accommodate the volume of the installation to be drained.
- ⇒ start the pump
- ⇒ place valve 21 in the FD position
- ⇒ make an air entry to valve 24

The operation is finished after evacuation of the foam visible in the transparent hose

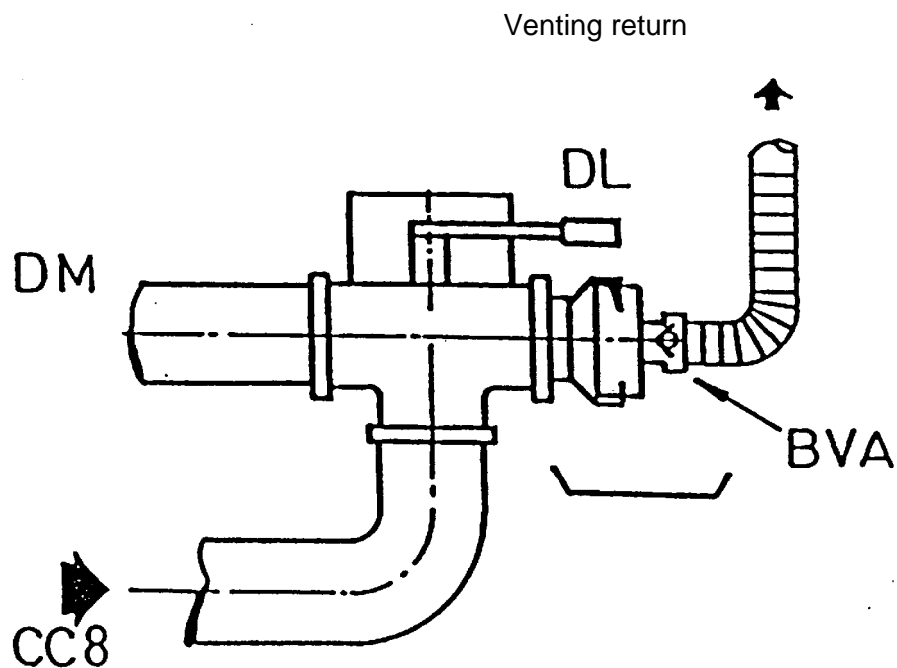

The plug ADP is mounted on the free draining port (FD) and when the valve lever is placed in this position, allows draining by the venting return, the suction piping, the DMX 3 MF and the pump.

## DISCHARGING A MEASURED COMPARTMENT USING THE PUMP

- ↪ Remove the plug ADP (26), connect the valve 21 to the storage tank, connect the hose 17 to the compartment to be drained, open the corresponding valve and start the pump. When draining is completed, drain the hose into the storage tank.

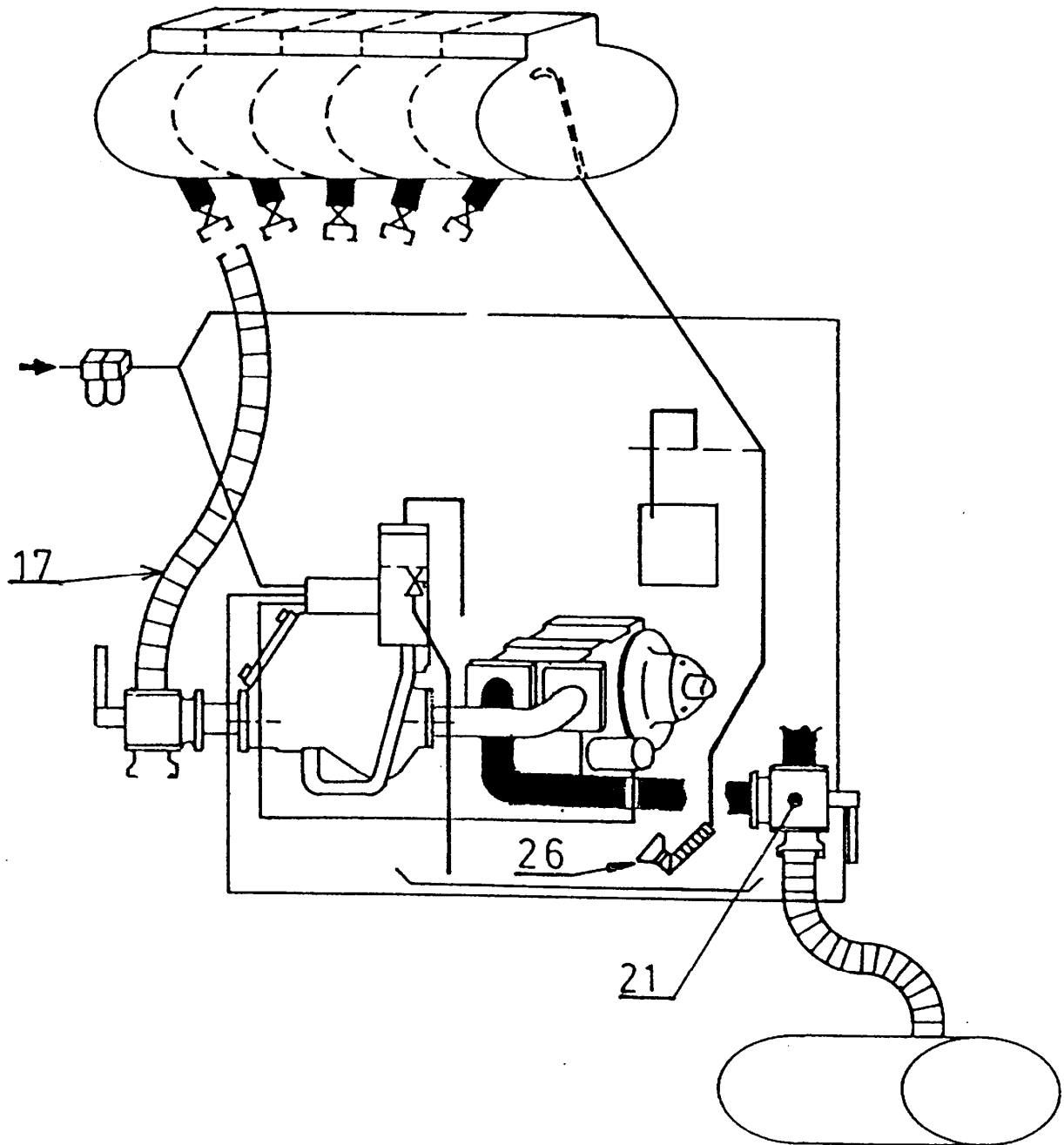



## UNMEASURED RECOVERY

- ↪ Connect the tank from which the recovery is to be made to the valve 25.
- ↪ Remove the plug ADP 26 and connect the valve 21 using a hose to the compartment to be filled through the dome (do not forget to maintain hose in the compartment). Start the pump and carry out the recovery.

Please note :

In recovery, once the pump has been started, it is not necessary to run it at too high a speed because depending on the suction conditions, a state of cavitation can be quickly reached, that is : poor functioning of the pump, noise, vibration, and flow inferior to normal flow considering the pump speed.

To return to correct functioning, it is only necessary to reduce the rotation speed of the pump, the length of the hose and to increase the hose's diameter.

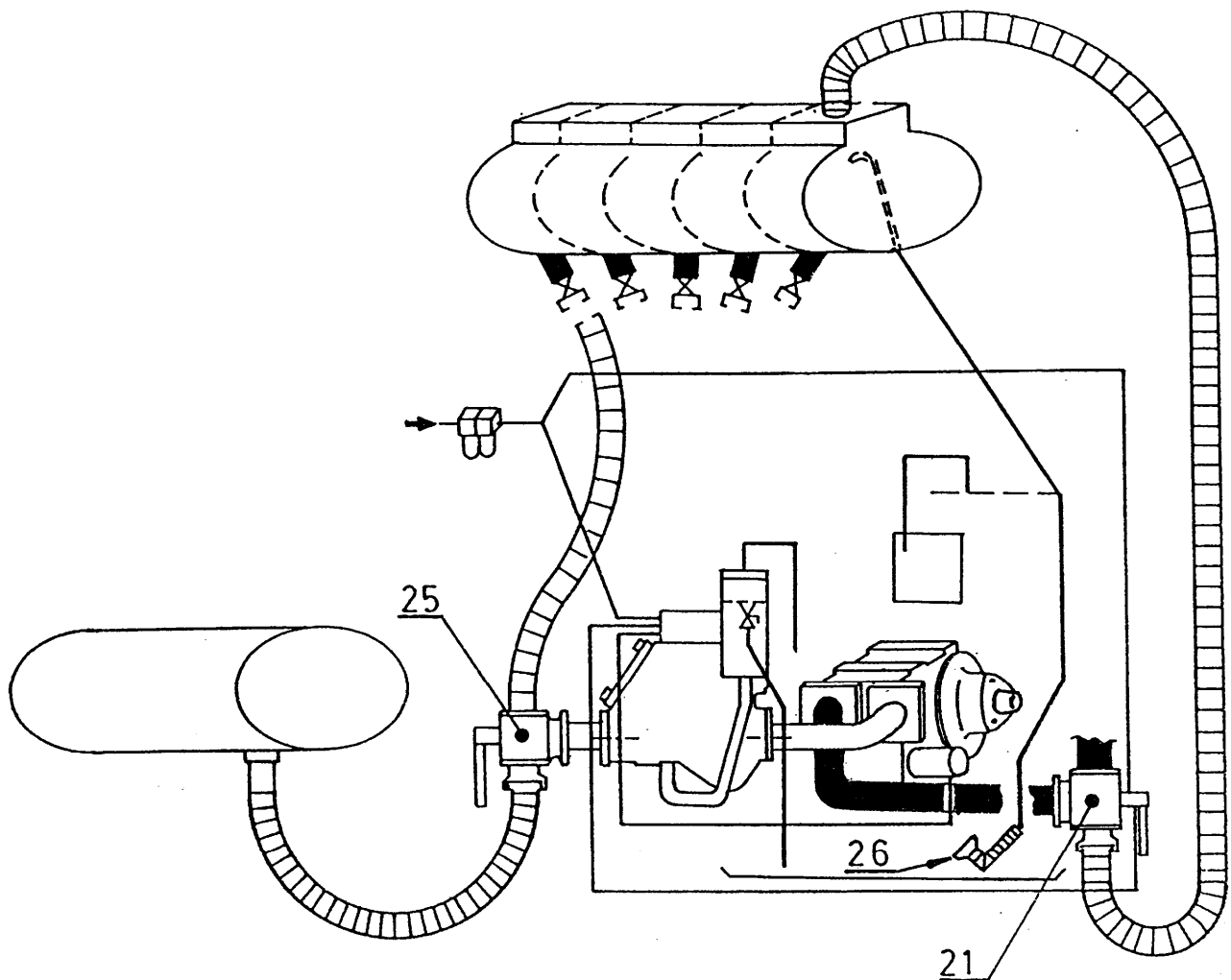

## OPERATION USING THE PUMP AS A TRANSFER PUMP

- ✎ Remove the plug ADP (26), connect the tank from which the transfer is to be made to the valve (25), connect the valve (21) to the tank to be filled and start the pump.

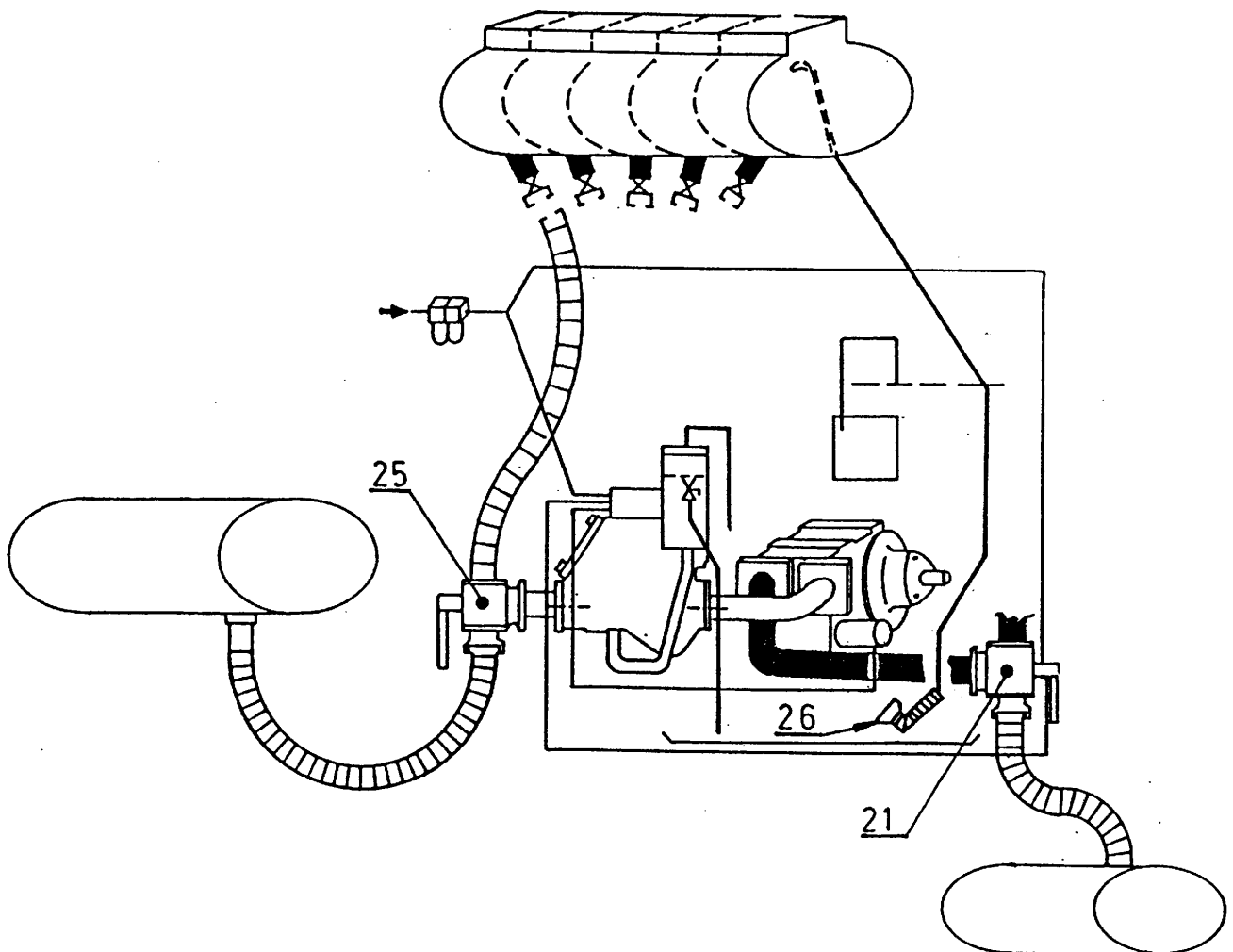

## FLOW DETECTOR

The flow detector is controlled by simple manipulation of the nozzle. It is obligatory that the flow detector be linked to a pneumatic acutation cylinder, its effect is to :

- ✓ accelerate the engine turnover
- ✓ increase the pump pressure, when the nozzle is opened and the flow goes over the preset threshold (approximately 5 to 7 m<sup>3</sup>/h)
- ✓ slow the engine turnover
- ✓ reduce the pump pressure, when the gun is closed and the flow falls below the preset threshold (approximately 5 to 7 m<sup>3</sup>/h)

Note – For a good functioning, the flow regulator must be regulate for a delivery > at the preset Threshold (5 to 7 m<sup>3</sup>/h)

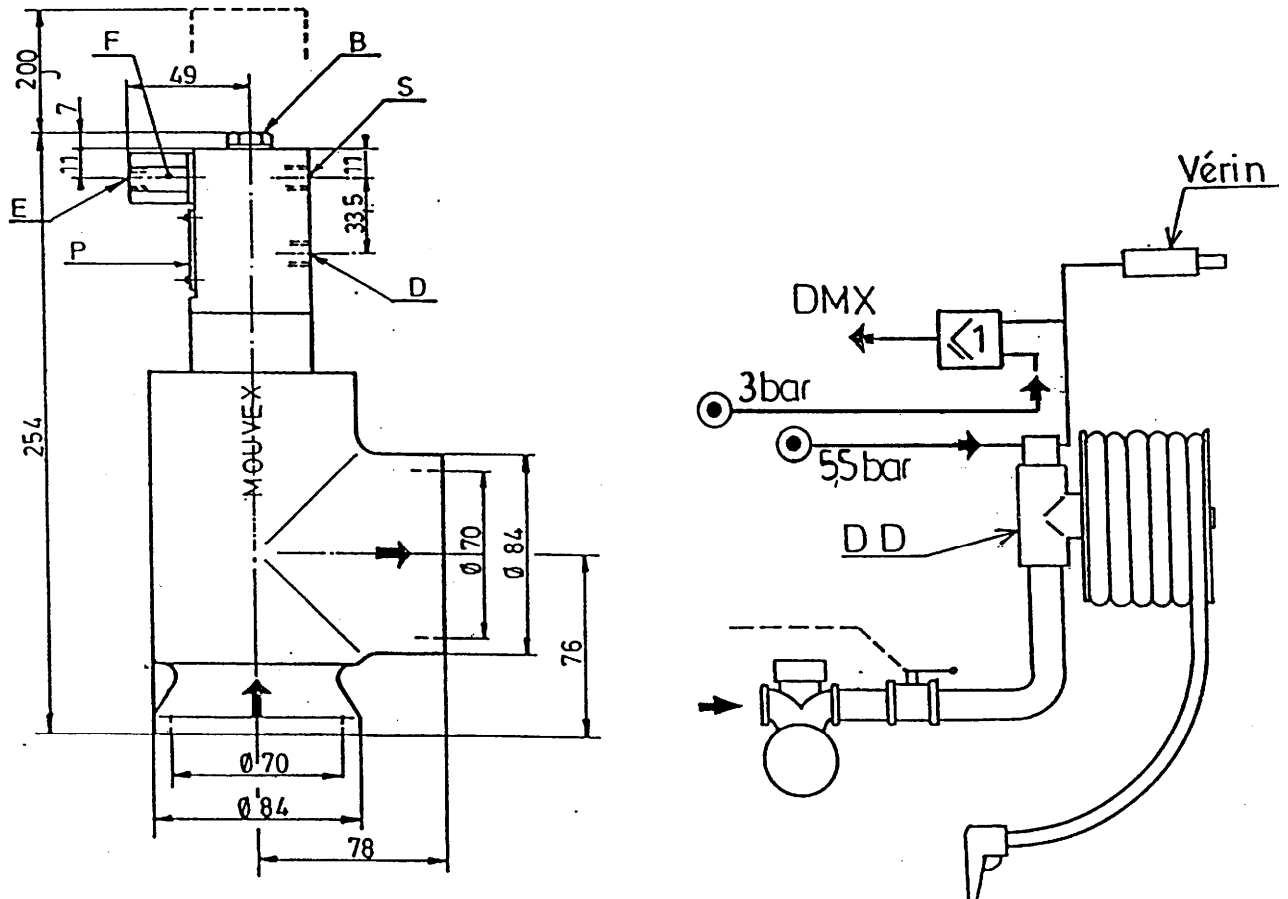

B Regulation access cover  
 D Decompression outlet G 1/8  
 E Compressed air inlet G 1/8  
 F Microfilter

J Dismantling clearance  
 P Plate  
 S Outlet for use with compressed air G 1/8

**EXPLODED VIEW**

DMX

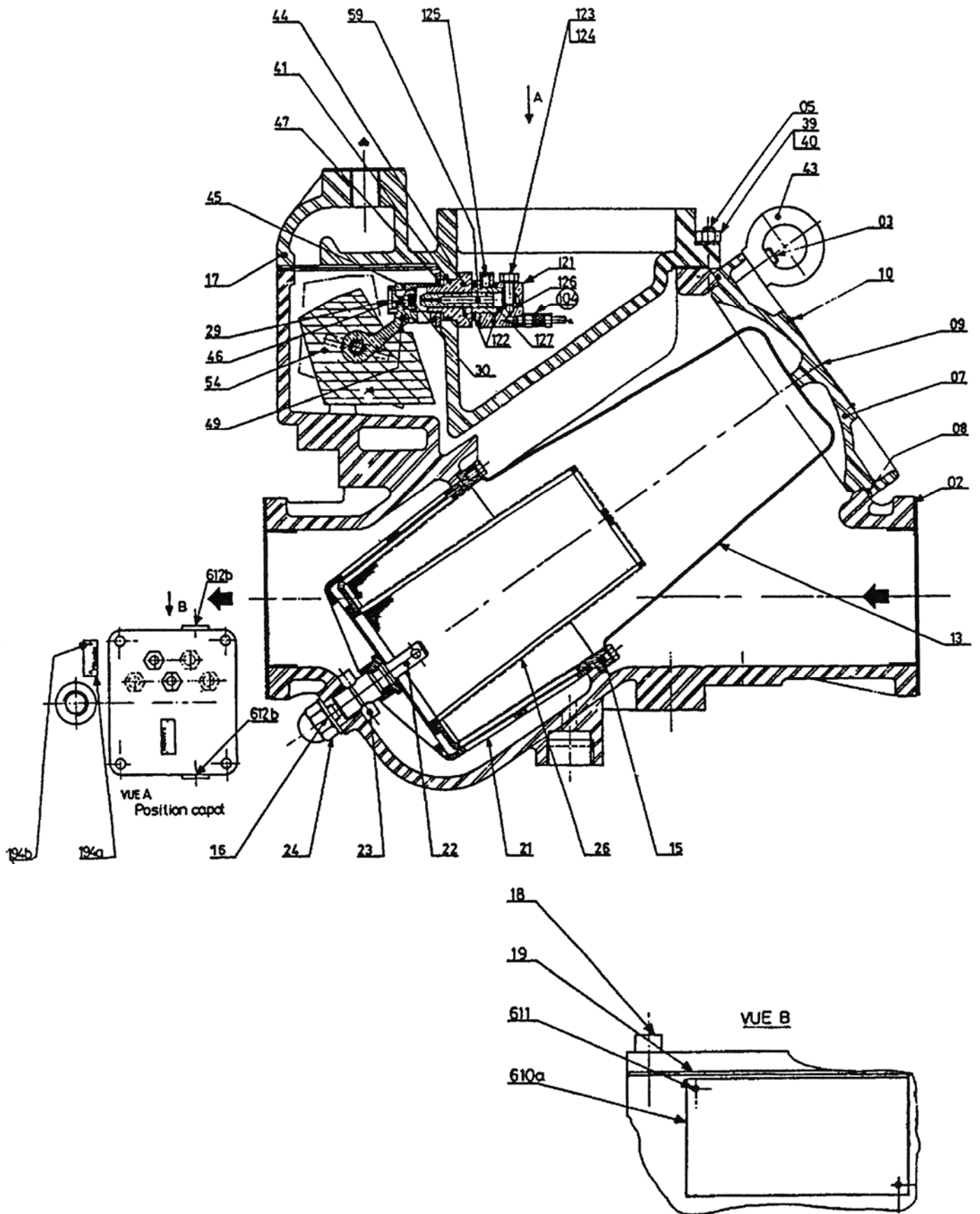

COMPLETE DRY VALVE

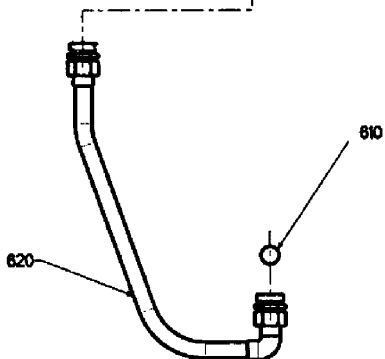
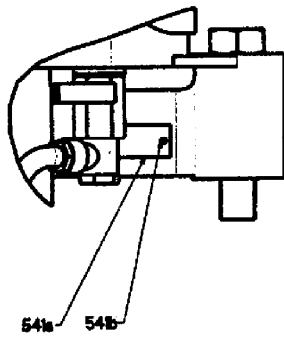
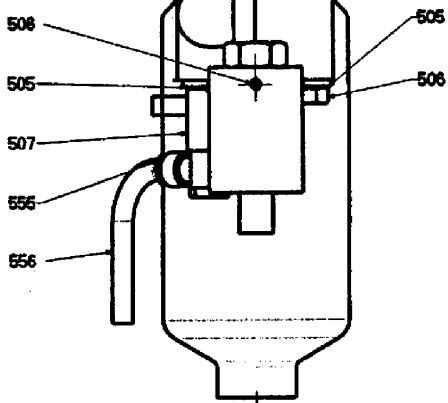
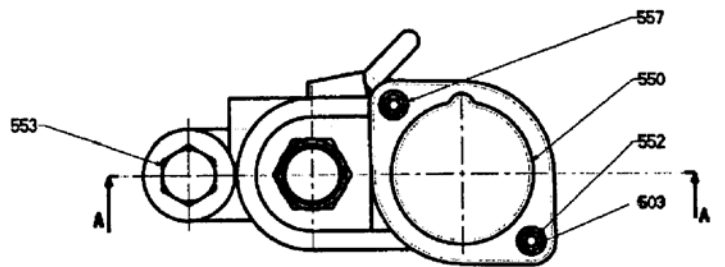
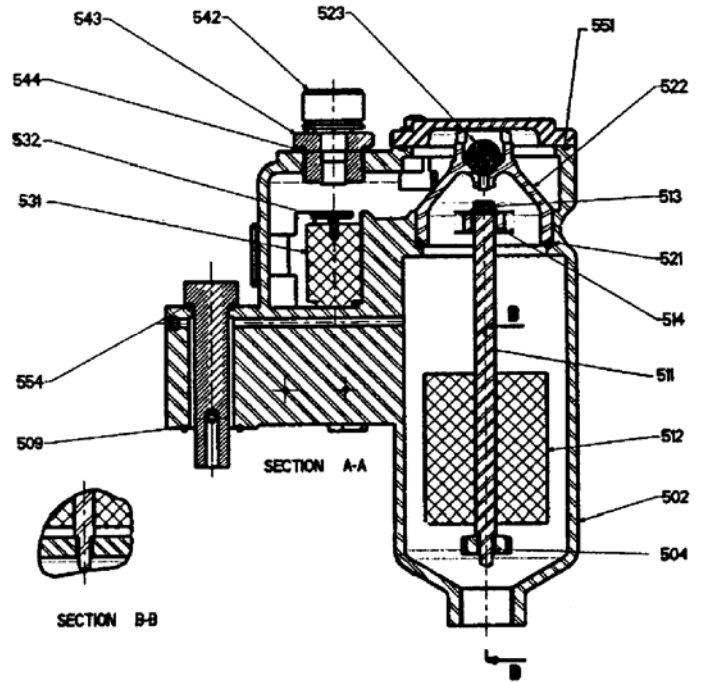

# DMX COVER

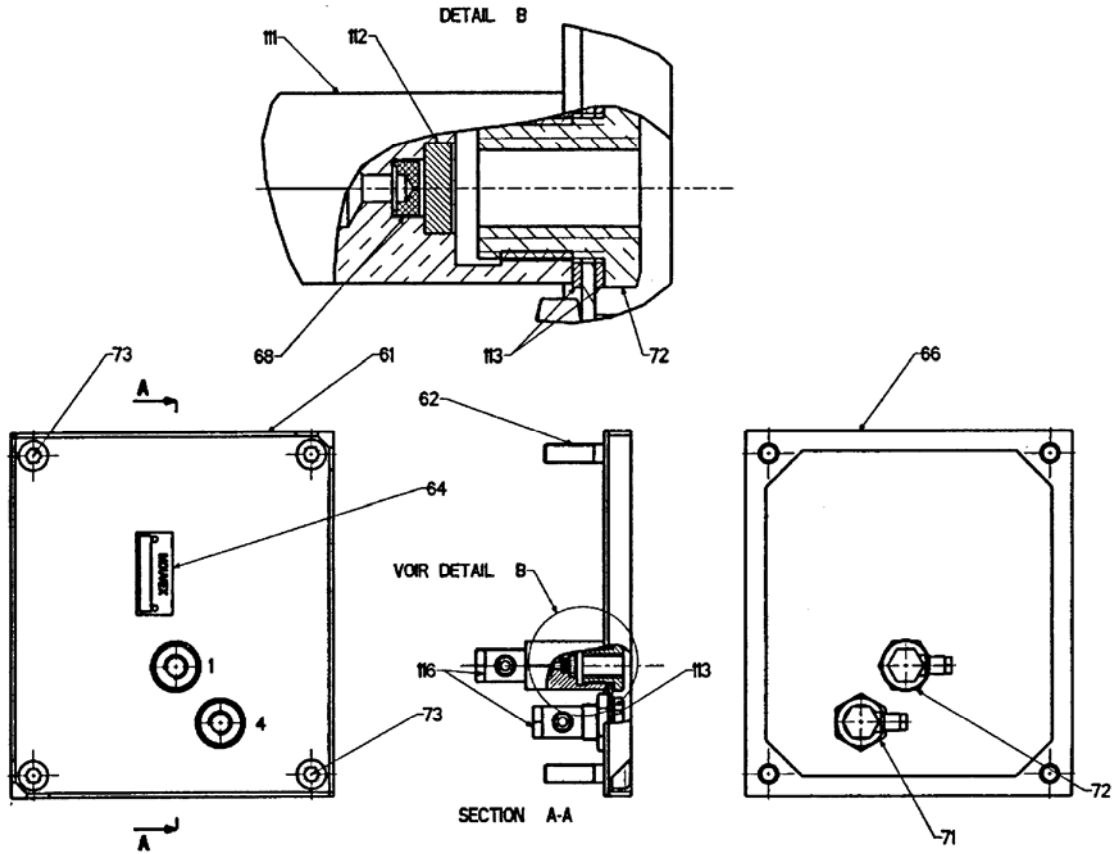

# DMX MF COVER

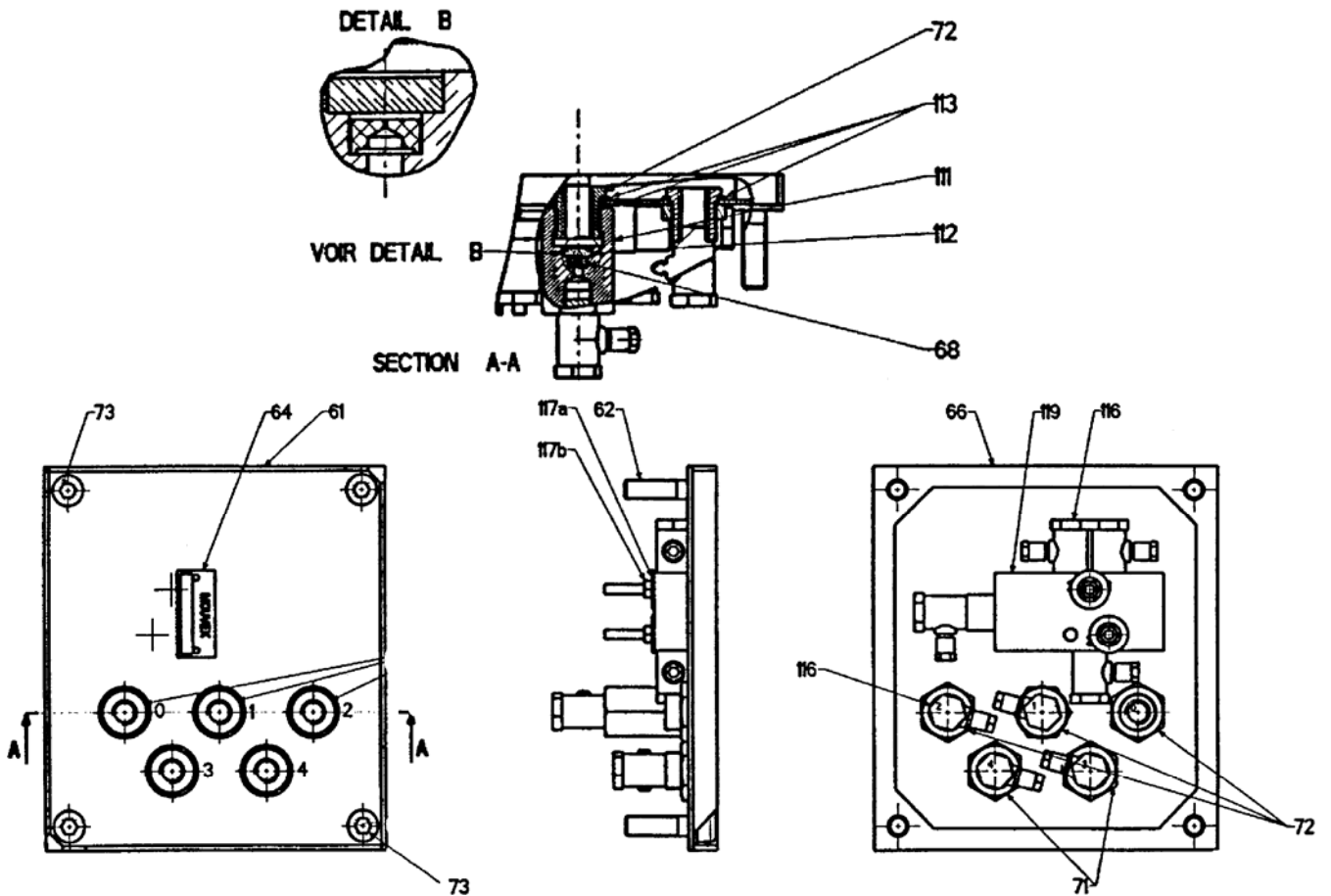

## **MALFUNCTIONING**

### **CAUSES AND REMEDIES**

<b>PROBLEMS</b>	<b>POSSIBLE CAUSES AND REMEDIES</b>
No flow See 6 - 15	1 - Air intake on suction pipe
Irregular flow See 1 - 2 - 3 - 7 - 8	2 - Vacuum $\geq 0.150$ bar in the DMX → Reduce losses of head on suction pipe or reduce flow rate
No high flow rate See 4 - 5 - 7 - 8 - 9 - 10 - 15 - 16	3 - Vortex effect in the compartment → Install an anti-vortex device
No low flow rate See 10 - 11	4 - DMX filter clogged → Clean the filter
Hydrocarbons in the pneumatic circuit See 9	5 - No air or not enough air in the bypass → Check circuit sealing and calibration of pressure regulators
The counter does not stop when there are no more products to supply See 7 - 8 - 12 - 14	6 - Condensate chamber of dry valve full → Bleed it using valve (507), check that . Foreign bodies do not affect movement of the float (512) . The seal (513) is in good condition
Metrology error on stock rupture test See 12 – 13	7 - Cover (14) HS assembly may have a sealing fault at the float valve (29) → Replace cover assembly
	8 - Cover (60) HS assembly may have a sealing fault or incorporate an operating fault in the valve (68) → Replace cover assembly
	9 - Bypass diaphragm pierced → Replace diaphragm
	10 - Float detector adjustment wrong → Refer to flow detector Instructions for adjustment
	11 - Exhaust pipe of flow detector clogged
	12 - Calibration valve inappropriate or defective → Check compliance with recommendations
	13 - Operating pressure too low → Check compliance with recommendations. Add a diaphragm, if necessary, to increase losses of head.
	14 - Defective FD valve → Check that it does not send air to the DMX at (3) when in MD position
	15 - Closing or blocking of a component in the system → Check opening of valves and the counter
	16 - Hydrocarbon paraffins due to excessively low temperature → Temporarily remove the top basket (25)