

mouvex

METERED RECEIVING OF HYDROCARBONS

CENTREX MULTI 60 CMA

(storage above ground)

INSTALLATION

Technical Instructions N° 826a II

mouvex 5, rue du Sahel - F 75012 PARIS

STORAGE

The equipment awaiting installation must be stored in a dry sheltered place; with the counter protected (by its cover if it has one).

INSTALLATION

Installation shall conform to the standard diagram approved by the Instruments Department (DIRECTION REGIONALE DE L'INDUSTRIE ET DE LA RECHERCHE) and be carried out by an installer who has received the authorization of the DRIRE or its Technical Services department.

The unit does not undergo prior examination in the factory.

The primary inspection, which it is the installer's responsibility to request, will be carried out on site by the local DRIRE which will stamp the identification and stamping plate fixed to the unit both on this occasion and during its routine visits.

Fixing of the chassis

Make sure that the chassis is horizontal and is in no way distorted by the fixing.

Connection of the pipes

The assembly is supplied with counter-flanges.

See to it that the pipes do not exert any abnormal stress on the set (if necessary, there should be brackets to support the pipes and valves).

Motor

This must be effectively protected from overloads by means of a suitably set circuit-breaker. During start-up, make sure that the strips in the terminal box are in the correct position. Please refer to the motor connection instructions.

Set below ground

Clearance must be provided to permit dismantling (cf. overall layout plan). In all cases the sightglass must remain visible so that it is possible to check whether or not there is product in the tank.

It is strongly recommended that the set should be properly protected and essential that there should be rainwater drainage.

FEEDING

Because the pump is of the centrifugal type without self-priming, it has to be gravity-fed; it must therefore be positioned sufficiently low relative to the draining valves of the tanks from which delivery is being taken (see general layout plan).

Make sure that the connection to the drainage valve is made with a pipe having an inside diam. equal to 80 mm and a length not exceeding 6 m. In the case of greater lengths it is recommended that pipes of 125 diam. should be used. For lengths of more than 50 m, please consult us.

Thermal decompression

Important: To avoid any problem caused by thermal expansion it is recommended that a check valve be placed in parallel with each intake circuit valve in the direction: CENTREX => storage tank.

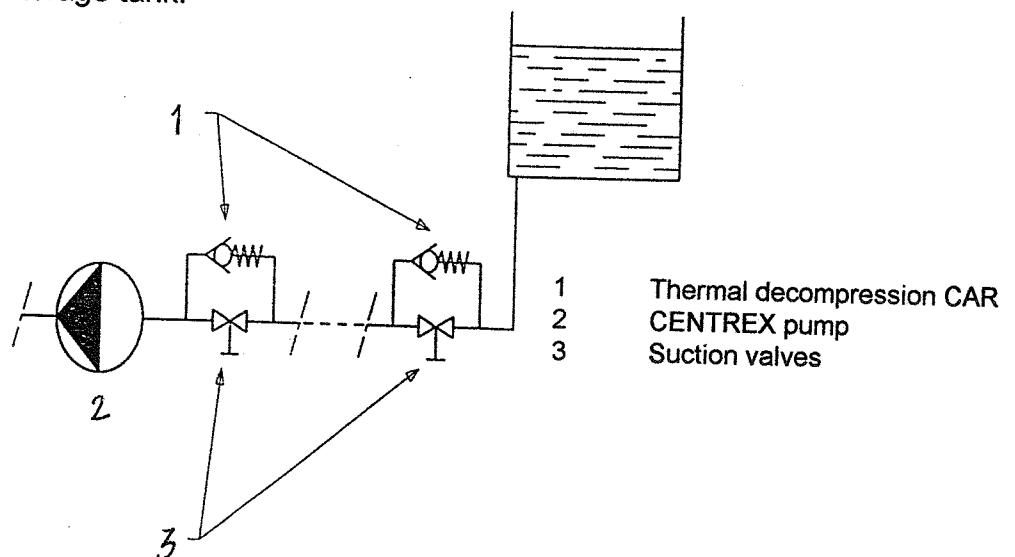

Venting

Venting to the atmosphere is provided by the degasser itself. No connection is necessary.

Recovery of vapours

In the installations with vapour recovery the outlet from the degasser must be connected to the vapour recovery system by a suitable pipe which does not create excessive losses of head (pipe diam. 1, minimum length) cf. diagram.

DELIVERY

The diameter, length and accessories (elbow, T-piece, valve...) of the delivery pipe shall conform to the specifications defined at the time of the order. Our guarantee depends on this conformity.

To prevent water hammer, the loading arm shall be equipped with a delayed-closure valve which is to be set according to the manufacturer's instructions.

The distance between the counter and the loading arm shall be such that the volume between these two elements is smaller than the delivery.

APPLICATION

Pumped products

There must be rigid conformity with the instructions defined in the equipment specification.

Apart from the general safety conditions which must be observed (earthing of the vehicle, etc.), metered receiving requires the following additional operations:

- Insert the docket in the counter and turn the crank or the actuation button.
- Open the storage valve.
- Start up the set.
- Open the valve of the loading arm and proceed to fill the compartment.
- Close the loading arm and turn the crank or the actuation button.
- Shut down the set.
- Close the storage valve

NOTE:

The quantity of product received is obtained by subtraction of the two numbers printed on the docket.

MAINTENANCE

Periodic cleaning of the filter is all the maintenance needed.

For the sets intended for the metering of FOD and (or) GO, use the special winter filter for the situation where waxing occurs in cold weather.

This filter can only be used for a short time.

It must be replaced by the fine filter as soon as the climatic conditions allow.

Inspection

The equipment is subject to periodic inspection by the DRIRE.

INSTALLATION

(1) Vapour recovery system

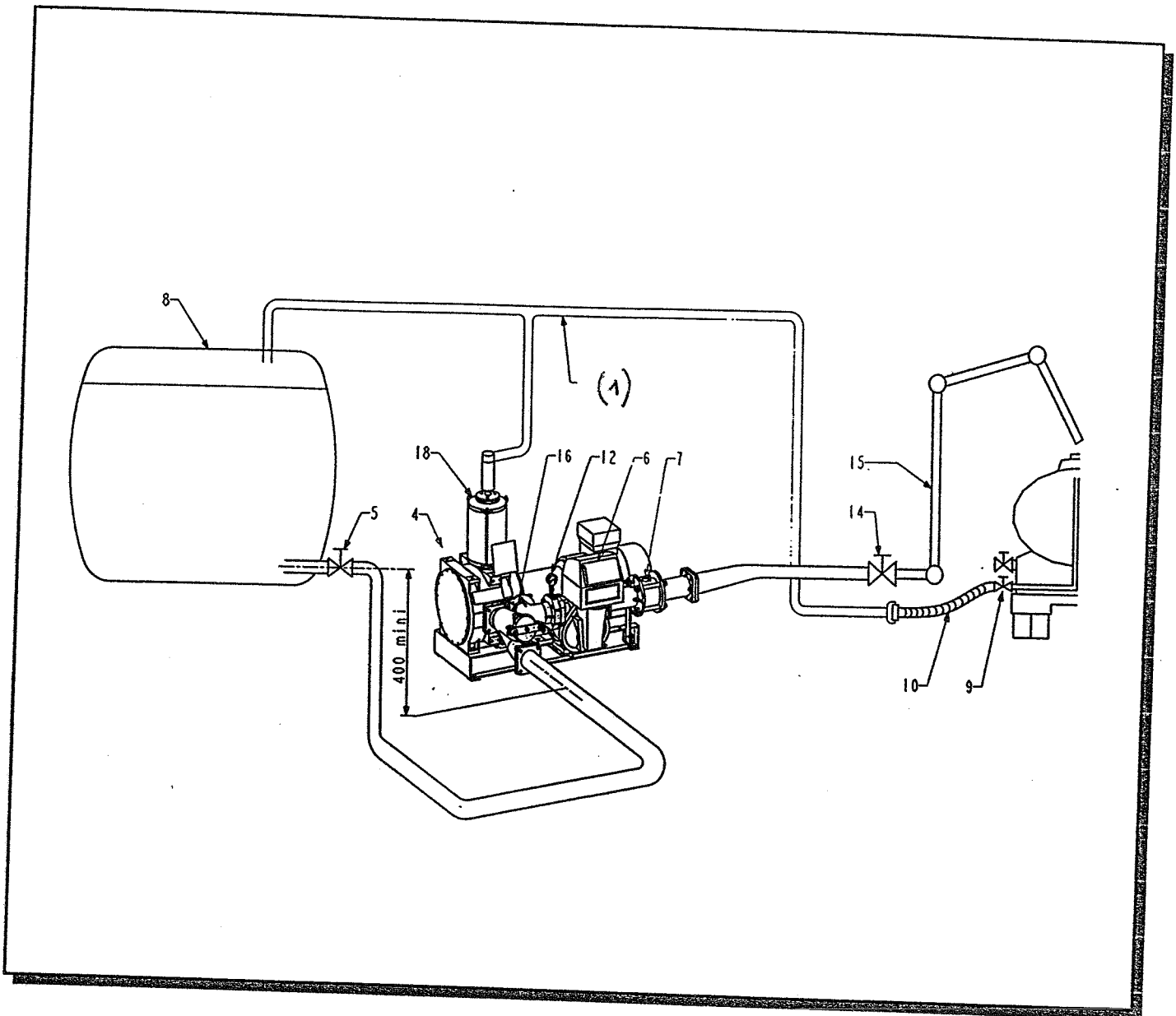

- 4 CENTREX MULTI pump
- 5 Isolating valve
- 6 Counter
- 7 Check valve
- 8 Over-ground storage
- 9 Vapour return valve

- 10 Vapour recovery unit
- 12 Pressure gauge
- 14 Valve
- 15 Loading arm
- 16 Filter
- 18 Dry degasser

OVERALL DIMENSIONS - mm

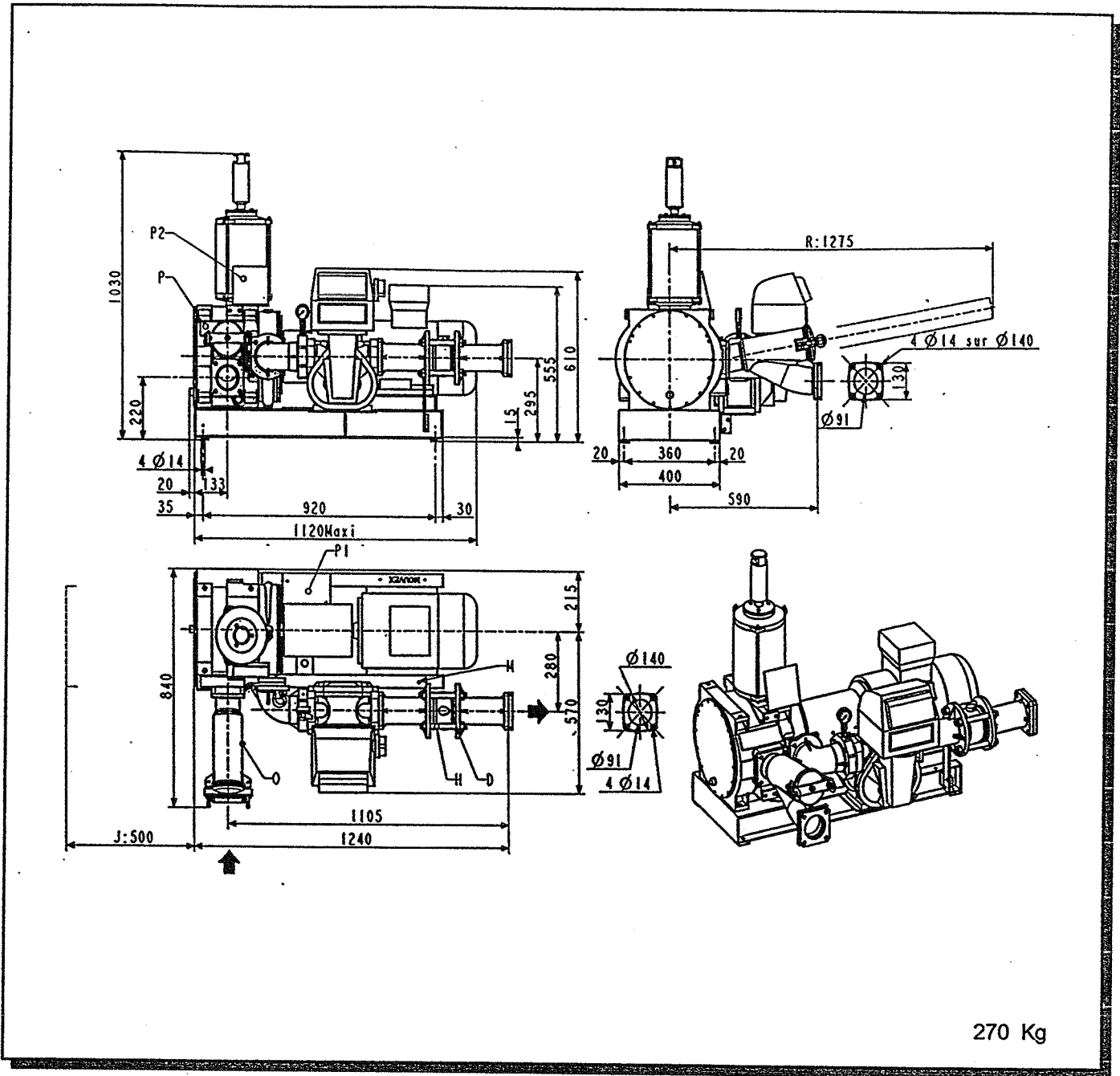

- | | | | |
|---|-------------------------|----|------------------------------------|
| D | Diaphragm location | P | Pump rating plate |
| H | Check valve | P1 | Identification and stamping plate |
| J | Release for dismantling | P2 | User's maintenance plate |
| M | Earthing terminal | R | Recess for filter cage dismantling |
| O | Suction filter | | |