

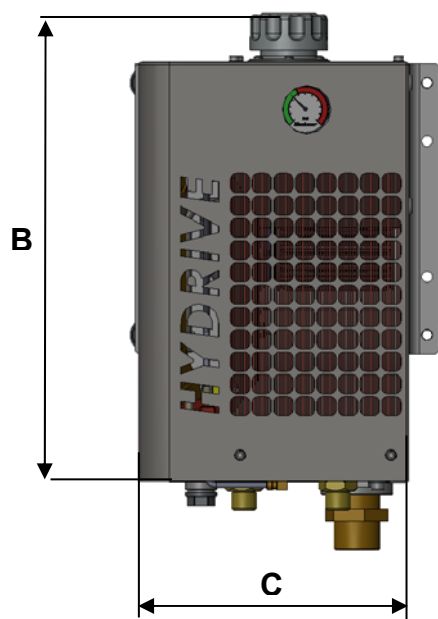

CHARATERISTICS

	STANDARD	AVAILABLE OPTIONS
Oil flow (l/min)	55 à 120	
Maximum pressure bar (PSI)	170 (2466)	280 (4061)
Power dissipation (KW)	10 for 40°C temperature rise	
Oil tank capacity (litre)	10	
Fan speed (rpm)	2800	
Fan hydraulic motor flow (l/min)	5.5	
Dimensions mm (in.)	A 526 (20.71)	
	B 498 (19.6)	
	C 278 (10.94)	
Weight dry kg (lbs)	31 (68)	

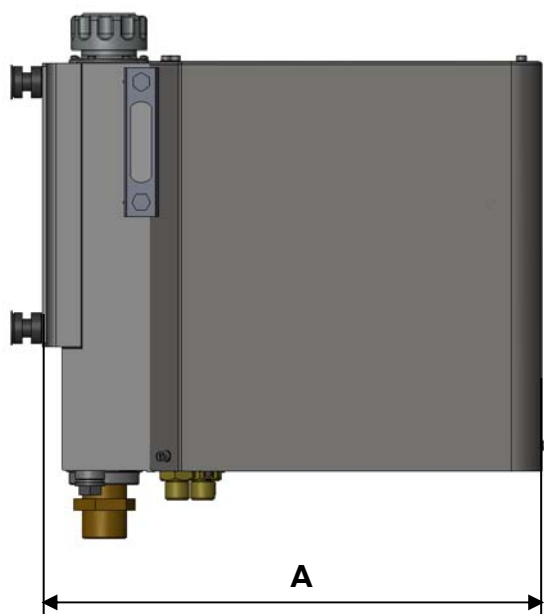

OPERATING LIMITS

	STANDARD MATERIALS
Minimum temperature °C (°F)	-40 (40)
Maximum temperature °C (°F)	50 (122)

MATIERES

Part No	PART NAME	STANDARD MATERIALS	AVAILABLE OPTIONS
2	Casing	Stainless steel	
16	Hydraulic bloc	Anodized aluminium	
30	Fan	Coated steel	
35	Hydraulic motor	Aluminium	
43	Radiator	Aluminium painted	
45 - 46	Hoses	Rubber	
114	Vibration pads	Rubber	

