

**CHARACTERISTICS**

		STANDARD	AVAILABLE OPTIONS
<b>Technology</b>		Eccentric Disc Mouvex®	
<b>Maximum Flow rate at 1 cSt L/h (GPM)</b>		12000 (52.8)	
<b>Displacement per revolution l (gal)</b>		0.37 (0.0977)	
<b>Ports</b>		DN65 SMS1145	DN65 DIN11851 2 ½" Clamp ASME-BPE-2009
<b>Pump heating</b>		None	
<b>Dimensions mm (in.) (With SMS connections)</b>	<b>A</b>	427.5 (16.8)	
	<b>B</b>	361 (14.2)	
	<b>C</b>	165 (6.5)	
	<b>D</b>	329 (13)	
<b>Weight kg (lbs)</b>		62 (137)	

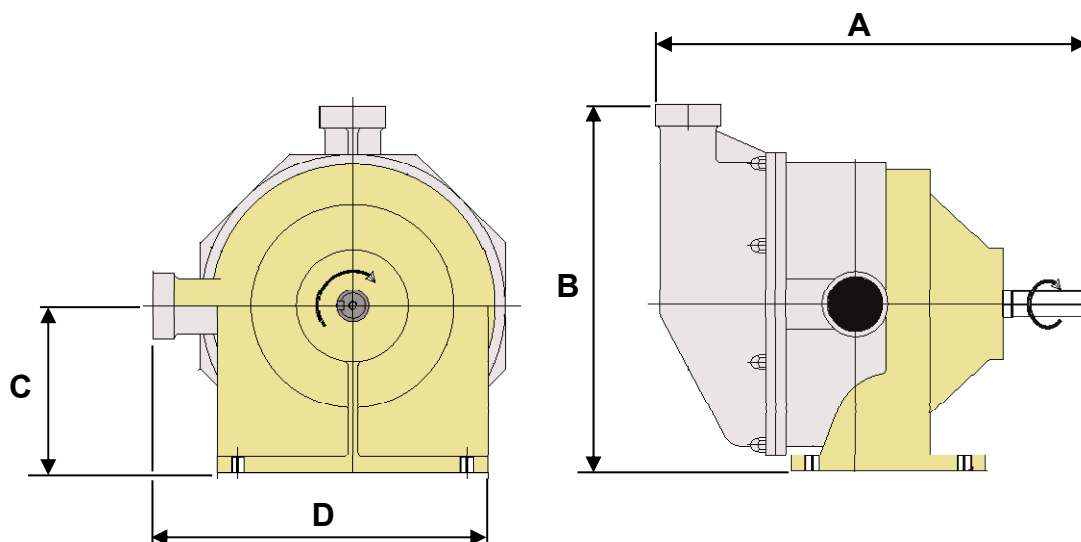

### OPERATING LIMITS

	STANDARD MATERIALS
Minimum temperature °C (°F)	0 (32)
Maximum temperature °C (°F)	80 (176)
Maximum in-pump dynamic viscosity cSt (SSU)	15000 (69000)
Maximum differential pressure bar (psi)	6 (87)
Maximum inlet pressure barg (psig)	3 (44)
Maximum speed rpm	500
Maximum solid particle size mm (in)	2 (0.08)
Maximum soft particle size mm (in)	10 (0.39)

### MATERIALS OF CONSTRUCTION

Part No	PART NAME	STANDARD MATERIALS	AVAILABLE OPTIONS
100	Inlet tube	316L Stainless Steel	Polished external surfaces
201	Cylinder	316L Stainless Steel	
301	Piston	CY5SnBiM (anti galling alloy)	
401	Front cover	316L Stainless Steel	Polished external surfaces
	Seal rings	FKM	
	Screws, nuts, washers	316L Stainless Steel	
	<b>Transmission Assembly</b>		
596	Bearings	Ball / Roller	
	Sleeve Assembly	FKM	EPDM
	Housing	Cast iron	
	Screws	Steel	
	Transmission Lubricant	Synthetic oil	

