

# MP7000 Series

## MECHANICALLY-ACTUATED METERING PUMPS



Where Innovation Flows



The Neptune MP7000 Series is a mechanically-actuated metering pump engineered from the ground up to be more robust and durable than similar mechanical metering pump designs. The MP7000 pump incorporates the ruggedness of a hydraulic metering pump, eliminates the need for intermediate fluid or hydraulic oil to actuate the diaphragm and eliminates the potential for gearbox oil to contaminate the process since it has an oil-free gearbox design.

The result is a pump that provides reliable and accurate dosing of a wide range of mild to aggressive chemicals, including those used in industrial and municipal water and wastewater treatment, chemical processing and agriculture.

The MP7000 finned gearbox dissipates the heat created during normal operation more readily than other designs. The straight-through flow design of the MP7000 liquid end and the elimination of the contour plate result in improved flow characteristics, making the pump well-suited for pumping difficult chemicals such as viscous fluids, shear-sensitive fluids and fluids with suspended solids.

# MP7000 Series MECHANICALLY-ACTUATED METERING PUMPS

## FEATURES AND BENEFITS

- 10:1 turndown via micrometer-type knob with high-contrast, easy-to-read scale
- Repeatable metering accuracy is  $\pm 2\%$  of full scale (at constant hydraulic conditions)
- All models include standard 63 IEC motor adapter
- Heavy-duty, corrosion-resistant aluminum gearbox
- Finned gearbox design dissipates heat more efficiently than other designs
- Rugged bronze gears are quiet-running and provide long service life
- Oversized check valves improve performance and minimize friction losses
- Short stroke length reduces diaphragm stress and promotes longer diaphragm life
- Superior performance when pumping chemicals such as sodium hypochlorite, which can off-gas
- Max capacity up to 27 gph (102 L/h)
- Max pressure up to 235 psi (16 bar)

## OPTIONS

- Automatic speed control with variable frequency or SCR drive
- Sodium Hypochlorite Gas Bleed head that allows venting of accumulated gas
- Sodium Hypochlorite Gas Bleed designed with an automatic air-release valve to allow venting of gas produced by chemicals

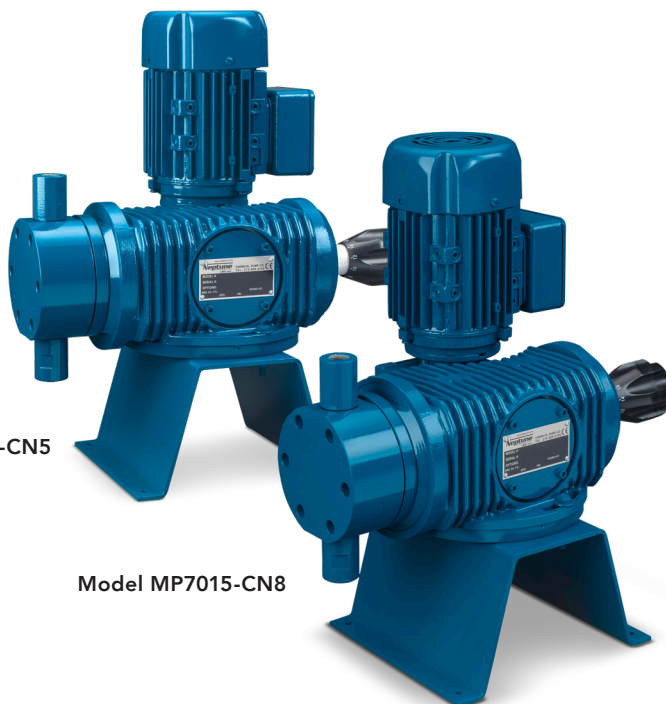

Model MP7010-CN5

Model MP7015-CN8

## SELECTION CHART

MODEL	MATERIAL OF CONSTRUCTION	MAX CAPACITY AT 1/4 HP		MAX PRESSURE		STROKES PER MINUTE	STROKE LENGTH INCHES (MM)	DIAPHRAGM DIAMETER INCHES (MM)	SHIPPING WEIGHT LB. (KG)
		GPH	L/H	PSI	BAR				
MP7007-AN3 MP7007-AN5 MP7007-AN8	316SS PVC PVDF	2-3/10	8.8	235	16.2	233	0.085 (2.2)	1.44 (36.5)	38 (17)
MP7015-BN3 MP7015-BN5 MP7015-BN8	316SS PVC PVDF	4-4/5	18.1	200	13.8	117	0.09 (2.3)	1.9 (48)	38 (17)
MP7010-BN3 MP7010-BN5 MP7010-BN8	316SS PVC PVDF	6-9/10	21.6	200	13.8	175	0.09 (2.3)	1.9 (48)	38 (17)
MP7007-BN3 MP7007-BN5 MP7007-BN8	316SS PVC PVDF	9	34.1	200	13.8	233	0.09 (2.3)	1.9 (48)	38 (17)
MP7015-CN3 MP7015-CN5 MP7015-CN8	316SS PVC PVDF	9	34.1	150	10.4	117	0.105 (2.7)	2.8 (71)	43 (20)
MP7010-CN3 MP7010-CN5 MP7010-CN8	316SS PVC PVDF	13-1/2	51.1	150	10.4	175	0.105 (2.7)	2.8 (71)	43 (20)
MP7007-CN3 MP7007-CN5 MP7007-CN8	316SS PVC PVDF	18	68.1	150	10.4	233	0.105 (2.7)	2.8 (71)	43 (20)

## MATERIALS OF CONSTRUCTION

MATERIAL CODE	PUMP HEAD	CHECK VALVE BODY	CHECK VALVE BALL	DIAPHRAGM	VALVE O-RING
N3	316SS	316SS	316SS	PTFE	None
N5	PVC*	PVC*	Ceramic	PTFE	FKM
N8	PVDF**	PVDF**	Ceramic	PTFE	FKM

\* PVC Heads are suitable for temperatures to 125°F (50°C)  
 \*\* PVDF Heads are suitable for temperatures to 200°F (93°C)  
 Valve O-ring is not used on the -DN3 pump heads

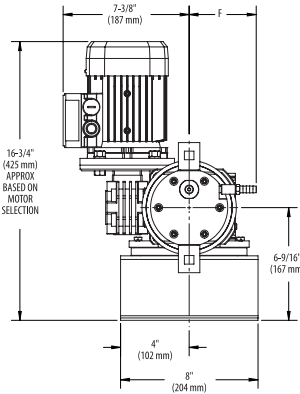
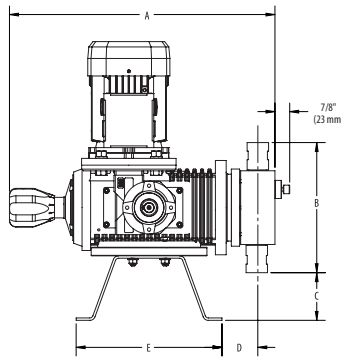
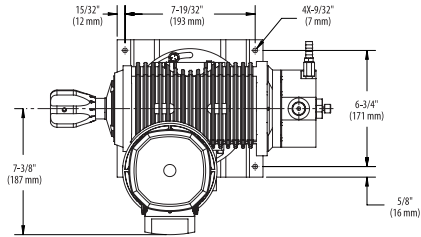

## DIMENSIONS

MODEL	ITEM	INCHES (MM)
MP7007-AN	A	15 (381)
	B	5-7/8 (150)
	C	3-5/8 (92)
	D	1-3/8 (35)
	E	8-1/2 (216)
	F	3-9/16 (91)
MP7007-BN MP7007-CN MP7010-BN MP7010-CN MP7015-BN MP7015-CN	A	16 (406)
	B	7-1/2 (191)
	C	2-13/16 (71)
	D	2 (51)
	E	8-1/2 (216)
	F	3-15/16 (100)

## SPARE PARTS KIT

The MP7000 Series Spare Parts Kit contains the liquid-end parts most susceptible to wear during a year of normal use. To keep the pump in good working order, Neptune recommends having a kit readily available.

MODEL	PUMP HEAD SIZE	PUMP HEAD MATERIAL	SPARE PARTS KIT NUMBER
MP7007	ANX	316SS	005357
MP7007		PVC	
MP7007		PVDF	
MP7007/MP7010/MP7015	BNX	316SS	005360
MP7007/MP7010/MP7015		PVC	005361
MP7007/MP7010/MP7015		PVDF	005362
MP7007/MP7010/MP7015	CNX	316SS	005363
MP7007/MP7010/MP7015		PVC	005364
MP7007/MP7010/MP7015		PVDF	005365



# Recommendations

## RECOMMENDED PIPE DIAMETER AND LENGTH

	MODEL	
	MP70XX-ANX MP70XX-BNX MP70XX-CNX INCHES (MM)	MP70XX-DNX INCHES (MM)
Suction Pipe Diameter	1/2 (12.7)	3/4 (19.1)
Max Lift	4' (1.2 m)	4' (1.2 m)
Discharge Pipe Diameter	3/8 (9.5)	1/2 (12.7)
Minimum Orifice At Injection Point	3/8 (9.5)	1/2 (12.7)

## PULSATION DAMPENERS

Remove the pulsating flow caused by a pump's reciprocating action, ensuring a smooth, laminar flow.

- Available in PVC, polypropylene, 316SS and C-20 (with FKM or EPDM bladders)
- Use of a pulsation dampener is required if the discharge pipe is more than 10 ft. (3 m) long for the 70XX model and the discharge pressure is more than 25 psi (1.8 bar).



## PRESSURE RELIEF VALVES

Relief valves protect piping and system from overpressure.

- Available in PVC, 316SS, PVDF and C-20 materials
- Standard sizes 1/2" through 1-1/2"



## BACK PRESSURE VALVES

Back pressure valves are adjustable to a maximum of 50 psi (3.5 bar). Ensure the set pressure is maintained at the pump outlet port (discharge) to assure accurate metering and prevent siphoning. Required accessory when pumping to a low-pressure injection point below the tank level or when pumping from a bulk tank with a high head pressure.

- Available in PVC, 316SS, PVDF and C-20 materials
- Standard sizes 1/2" through 1-1/2"



## LEAK DETECTION

The MP7000 Series pump can be supplied with an optional diaphragm leak detector, which senses the early stages of diaphragm failure. The system consists of an electro-optic sensor mounted in the pump head behind the process diaphragm and a relay installed in a NEMA 4X enclosure. The leak detector can be wired to provide remote indication of diaphragm failure, shut down the pump and/or sound an alarm.

## USE ONLY FULL PORT VALVES IN SUCTION AND DISCHARGE LINES.

For more information on these additional solutions, visit us at [psgdover.com/neptune](http://psgdover.com/neptune).



PSG

22069 Van Buren Street  
Grand Terrace, CA 92313-5651 USA

P: +1 (909) 422-1700 • F: +1 (909) 783-3440

[psgdover.com/neptune](http://psgdover.com/neptune)

Distributed By:

Where Innovation Flows



DP-7000-19

© 2023 PSG, a Dover company

NPT-10009-B-06

Neptune reserves the right to modify the information and illustrations contained in this document without prior notice. This is a not-contractual document.