

Solenoid-driven Metering Pump

PZD Series

OPERATION Manual

— *Before beginning operation, read this manual carefully!* —

Ignoring the descriptions in this User's Manual and mishandling the unit may result in death or injury, or cause physical damage.

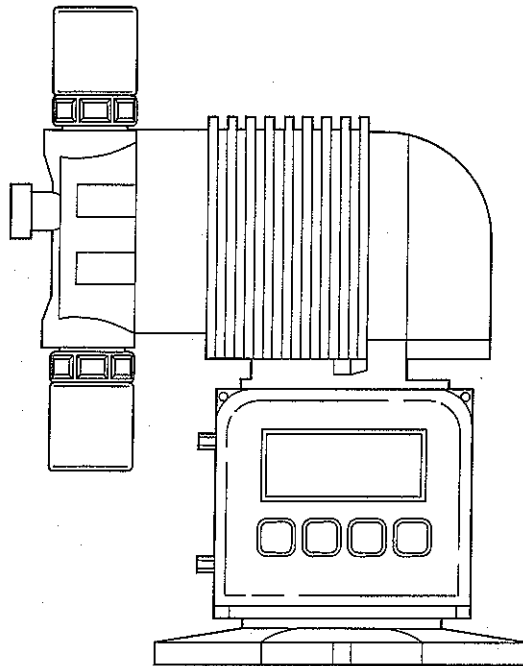

— Applicable Models —

PZD-31/61/12/32/52

ARPZD-31/61/12

- Thank you for purchasing this TACMINA product. Please read this manual carefully in order to ensure that you use the appliance safely and correctly.
- Be sure to keep this manual in a place where it will be easily available for reference.
- If the PZD series pump you bought conforms to special specifications not described in this OPERATION Manual, handle the pump according to details of separate meetings and drawings.

For Your Safety Operation

This manual is intended to help the operator to handle the product safely and correctly. In support of this aim, important safety-related instructions are classified as explained below.

Be sure to follow them at all times.



- If the product is operated incorrectly in contravention of this instruction, it is possible that an accident resulting in death or serious injury will occur.



- This indicates that improper operation can result in an injury or physical damage to the product.



- This indicates information that should always be followed to maximize the product's performance and service life.



- This indicates supplementary explanations.

Conditions of Use



- This pump cannot be used in explosion-proof areas, and in explosive/ignitable atmospheres.

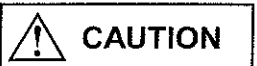

- This pump can be used for injection of chemicals only. Do not use this pump for other applications. Doing so might cause accidents or malfunction.
- This pump cannot be used for transferring fluids that contain slurry.
- The discharge volume cannot be adjusted by operating the valve on the discharge piping.
- This pump generates pulsation.
- Do not use this pump outside of the operating range indicated below. Doing so might cause malfunction.
 - Ambient temperature 0 to 40°C
 - * Maintain the pump in a temperature range of -10°C to +50°C during transportation and storage. Also, do not subject the pump to strong shocks.

Chemical handling conditions

Temperature 0 to 40°C
Viscosity 50 mPa·s or less

Max. pressure output

Standard specifications	PZD-31/61: 1.0 MPa	ARPZD-31/61: 1.0 Mpa
	PZD-12: 0.7 Mpa	ARPZD-12: 0.7 Mpa
	PZD-32: 0.3 Mpa	
	PZD-52: 0.2 Mpa	
Boiler specification	PZD-31: 1.5 MPa	

- * Note, however, that the maximum discharge pressure of PTFE hose connection (FTC/6TC) types is the pump specifications or 0.5 MPa, whichever is smaller, and that the maximum height above sea level at the installation site is 1000 m or less.

Transportation and Installation



- This pump does not conform to explosion-proof specifications. So, it cannot be used in explosion-proof areas, and in explosive/ignitable atmospheres.
- Install the appliance in a location where it will not come into contact with children or other people besides the operator.

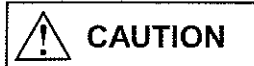

- Though this pump is designed according to outdoor specifications, it is made of plastic. Avoid installing the pump at locations (for example, direct sunlight or locations exposed to wind and rain) that might shorten its service life.
- Do not install this pump at humid or dusty locations. Doing so might cause electric shock or malfunction.
- If the discharge piping is provided with a cut-off valve, and when there is the danger that the piping will choke, install a relief valve on the piping immediately after the discharge side of this pump.
- Generally, the pressure-resistance performance of hoses drops. When a commercially available hose is used, be sure to use a hose that is chemically resistant and that withstands the operating temperature and pressure. Otherwise, the hose may break or chemicals may spray out.
- When using water-diluted solutions in cold areas, chemicals may freeze in the pump head or piping, damaging the pump and peripheral parts. Be sure to install heating apparatus or heat insulation.
- Water used in the pre-shipment test may remain on pump liquid-end parts. When using chemicals that generate gas or harden due to reaction with water, be sure to drain any water and allow liquid-end parts to dry before use.

Piping and Electrical Wiring



- Do not operate the pump when your hands are wet. This could result in electric shock.
- Do not turn the power ON during piping and electrical wiring. Attach a "Work In Progress" label to the power switch.
- Do not disassemble the main unit or circuits.
- Reliably ground the ground terminal. Failure to do so might cause electric shock.



- Electrical wiring must be performed by personnel such as an electrician having specialist knowledge.
- Be sure to connect and wire the ground lead (green) to prevent electric shock.
- Check the power voltage before wiring. Do not wire to a power supply outside of the rated voltage range.

Operation and Maintenance



- Do not operate the pump when your hands are wet. This could result in electric shock.
- If anything unusual occurs such as smoke or a burning smell during the operation, immediately stop operation and contact your supplying agent. Failure to do so could result in fire, electrical shock or damage to the product.
- Do not disassemble the main unit or circuits.
- During air release, chemicals spray forcefully from the tip of the air release valve. Be sure to attach an air release hose and return chemicals to the tank. At this time, either hold the air release hose by hand or secure

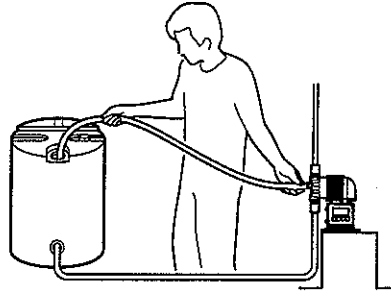

it in place.

- If you forget to open the discharge-side valve or if foreign matter clogs the discharge-side piping, the pressure in the piping and pump head may increase beyond the range indicated in the pump specifications. This may result in the chemicals leaking or spurting, or in damage to the pump or the piping.



- Before disassembling the liquid-end section for maintenance or repair, make sure to turn OFF the power and confirm that no voltage is supplied to the pump. Also, make sure that the power switch is not turned ON again during the maintenance or repair work.
- When handling the liquid-end section, be sure to wear protective coverings (rubber gloves, mask, protective goggles, chemical-resistant overalls etc.) appropriate for the chemicals being transferred.
- Before maintaining or repairing the pump, release the discharge-side pressure, drain the chemicals from the liquid-end section, and wash the pump with purified water or similar liquid.

Others



- Adopt preventative measures such as a chemical drain ditch in case chemicals flood out.
- When disposing of used pumps, ask an authorized industrial waste disposal expert to dispose of the pump in accordance with local laws and regulations.

Contents

— About This Product —

1	Checking the Product.....	1
1-1	Accessory List (standard specification)	1
1-2	Accessory List (boiler specification 31 model)	1
1-3	Accessory List (ARPZD: w/ automatic air release).....	1
2	Outline	1
3	Structure	1
3-1	Names of Parts	1
4	Principle of Operation	1
5	Model Code	2

— Installation and Piping —

6	Installation	3
6-1	Installation Site	3
6-2	Changing the Orientation of the Pump Upper Section	4
6-3	Piping on the VEC and VFC Types	4
6-4	Hose Piping When Injecting Sodium Hypochlorite on the CL Type	7
6-5	Piping on Boiler Specification Models ..	8
6-6	Piping on the ARPZD-CL (PZD w/ automatic air release)	9

— Electrical Wiring —

7	Electrical Wiring	11
7-1	Connecting the Power Supply and Ground Leads (connections common to all PZD types)	11
7-2	Recommended Protective Devices ..	12

— Operation —

8	Operation	13
8-1	Preparing for Operation	13
8-2	Releasing Air	13
8-3	Control Panel.....	15
8-4	Setting the Discharge Volume	15
8-5	Stopping Operation for an Extended Period	19
8-6	Preparations for Restarting Operation ..	19

— Maintenance and Inspection—

9	Maintenance and Inspection	20
9-1	Inspection during Operation (daily inspection)	20
9-2	Replacing the Valve Seat and Check Ball.....	21
9-3	Replacing the Pump Head.....	22
9-4	Replacing the Diaphragm (including the protective diaphragm)	23

— Troubleshooting —

10	Troubleshooting	25
----	-----------------------	----

— Customer Services —

11	Warranty.....	26
12	Repair Service	26
13	Contact Us	27

— Specifications —

14	Specifications.....	27
14-1	Performance Specifications Tables (PZD series)	27
14-2	Performance Specifications Table (boiler specification).....	27
14-3	Performance Specifications Table (ARPZD-CL w/ automatic air release) ..	28
14-4	Power Supply Specifications	28
15	Liquid-end Materials.....	28
16	Performance Curves	29
17	External Dimensions	30

— Consumables, etc. —

18	Consumables and Spare Parts	33
18-1	Consumables.....	33
18-2	Spare Parts	33
19	Options and Related Equipment	34
20	Glossary.....	34

Contents - Quick Search

About This Product	P- 1
Installation and Piping	P- 3
Electrical Wiring	P- 11
Operation	P-13
Setting the Discharge Volume	P-15
Maintenance and Inspection	P-20
Troubleshooting	P-25
Customer Services	P-26
Specifications	P-27
Consumables, etc.	P-33

1 Checking the Product

When unpacking, please confirm the following items:

- (1) Is the enclosed product the same model you ordered?
- (2) Do the details on the pump nameplate match your order?
- (3) Are all the accessories present and correct?
Please refer to the accessory list below.
- (4) Can you detect any damage due to vibration or shock during transportation?
- (5) Are there any loose or disconnected screws?

All TACMINA products are carefully checked prior to shipment. If, however, you find a defect, please contact your supplying agent.

1-1 Accessory List (standard specification)

Product	Quantity
PVC blade hose*	3 m
Air release hose (not provided for the 32/52 model)	1 m
Anti siphonal check valve	1
Foot valve	1
Pump installation nuts/bolts (M5 x 30)	2
Operation Manual	1

* With the FTC, 6TC and STC type, the hose is made of PTFE, and accessories are different.

1-2 Accessory List (boiler specification 31 model)

Product	Quantity
Nylon tube (discharge side)	2 m
PVC blade hose (suction side)	1 m
Air release hose	1 m
Strainer check valve for boilers (SUS304)	1
Foot valve	1
Pump installation nuts/bolts (M5 x 30)	2
Operation Manual	1

1-3 Accessory List (ARPZD: w/ automatic air release)

Product	Quantity
PVC blade hose (ARPZD□-31: dia. 4 mm x dia. 9 mm, -61/12: dia. 6 mm x dia. 11 mm)	3 m
Air release hose	1 m
Anti siphonal check valve	1
Foot valve	1
Pump installation nuts/bolts (M5 x 30)	2
Operation Manual	1

2 Outline

The solenoid-driven metering pump PZD Series is a solenoid-driven reciprocating pump having highly chemical resistant liquid-end parts and a compact body.

The pump can be used with 90 to 264 VAC, 50/60 Hz power supplies. Moreover, discharge performance has been adjusted to be uniform within this power voltage range.

3 Structure

3-1 Names of Parts

- PZD Series

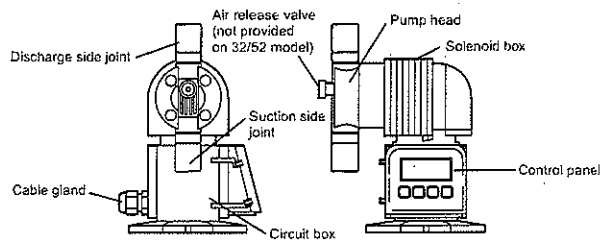

* On the ARPZD, the front of the pump head becomes the discharge side joint, and the upper section of the pump head becomes the air release joint.

4 Principle of Operation

(1) Electromagnetic power is generated when current flows to the solenoid coil from the power circuit built into the electronic circuits. This power becomes the suction force to suck in the drive plunger. When the drive plunger is sucked in, the diaphragm attached to the tip of the drive plunger is pushed out. When current flow stops, suction force is terminated, and spring action causes the drive plunger to return to its original position.

This is how reciprocating motion is generated.

(2) When the diaphragm on the tip of the drive plunger is moved by this reciprocating motion, the volume inside the pump head increases and decreases.

At the same time, negative and positive pressure is generated alternately inside the pump head to suck in and discharge chemicals.

- (3) When the diaphragm moves to the rear, negative pressure is generated inside the pump head. At this time, the check ball on the discharge side closes the flow path as shown in Figure 1 to prevent back flow of chemicals from the discharge piping. On the other hand, as the check ball on the suction side opens the flow path, chemicals flow into the pump head.
- (4) Next, when the diaphragm is pushed out to the front, positive pressure is generated inside the pump head. This causes the check ball on the suction side to close the flow path, and open the discharge side so that chemicals are discharged. (Figure 2)

(Figure 1)

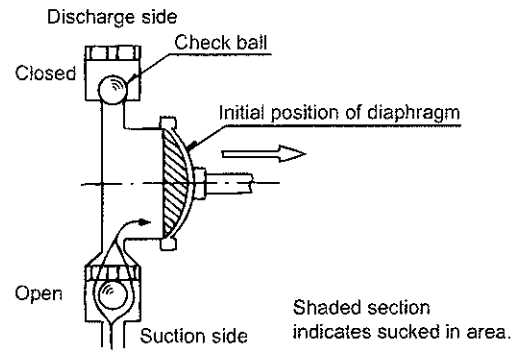

* The figure shows a single-stage check valve to simplify the description.

(Figure 2)

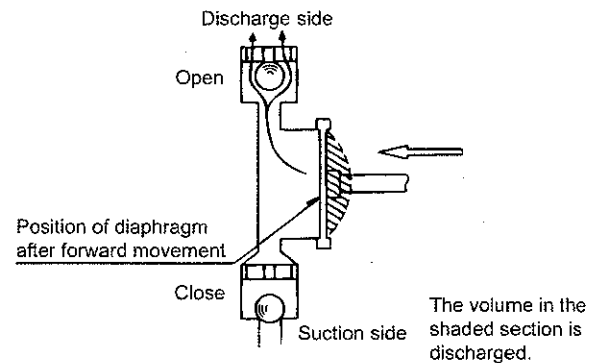

* The figure shows a single-stage check valve to simplify the description.

5 Model Code

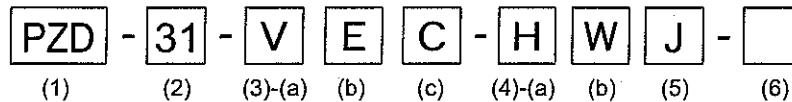

(1) Series name

PZD: PZD series

ARPZD: PZD series w/ automatic air release

(2) Model type (discharge volume standard)

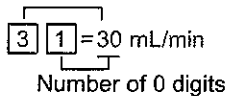

5 types: 31, 61, 12, 32, 52

(3) Liquid-end material

(a) Pump head

V: PVC

F: PVDF

6: SUS316 (PZD-31/61/12 model only)

S: SUS304 (PZD-32/52 model only)

(b) Valve seat, O-ring

E: EPDM

F: Special fluoro-rubber

T: PTFE

(c) Check ball

C: Ceramic

* On the CL type, a combination of (a) Acrylic, (b) Special fluoro-rubber, and (c) Ceramic is used.

NOTE

- Any combination of liquid-end material is possible. For details on liquid-end material combinations, see the Liquid-end Materials Table under Specifications. On all types, the diaphragm is made of PTFE.

(4) Specifications

(a) Connection type

H: Standard hose type

B: Boiler specification

(b) Joint specification

W: Standard

Dischargable viscosity

50 mPa·s or less

(5) Applicable area

J: Japan

(6) General specifications

None: Standard X: Special

6 Installation

6-1 Installation Site

⚠ WARNING

- This pump is not designed to explosion-proof specifications. It cannot be used in explosion-proof areas, and in explosive/ignitable atmospheres.
- Install the pump in locations out of the reach of children and personnel other than an administrator.
- If you forget to open the valve or clogging occurs inside the pump's discharge piping, there is the danger that pressure will rise excessively beyond the pump's specified operating range, that chemicals may spray out, or that piping may be damaged.

IMPORTANT

- Avoid installing the pump in the direct sunlight. Also, prevent it from being exposed to wind and rain.

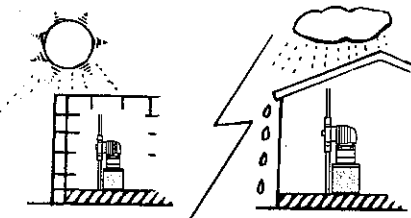

- Install the pump in a location that is well-ventilated during summer, and where chemicals will not freeze in winter.

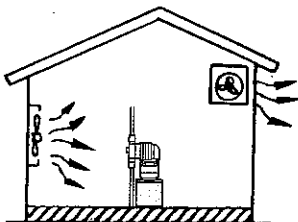

- Leave enough space to allow easy access for maintenance and inspection work.

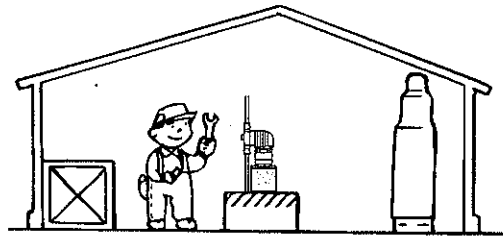

- Install the pump on a flat horizontal surface and fix it securely to prevent it from vibrating during the operation. If the pump is installed on an inclined surface, the pump may not be able to discharge properly or at all.

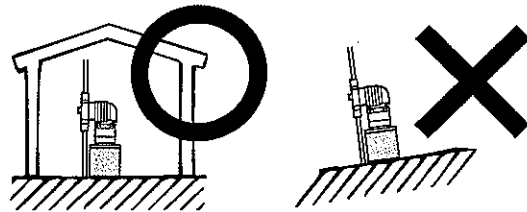

- To secure the pump, use the two mounting bolts (provided).

- * Of the four mounting locations, secure the pump at two opposite sides.

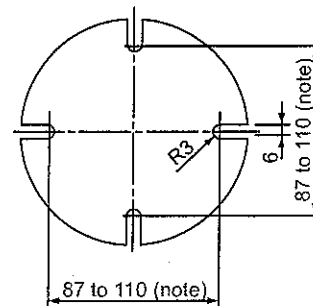

Note: The permissible mounting pitch is 87 to 110 mm.

6-2 Changing the Orientation of the Pump Upper Section

The pump upper section (pump head/solenoid box) can be fitted on the pump lower section (circuit box) facing three different directions.

Change the orientation of the pump upper section when piping restrictions make operation on the control panel difficult.

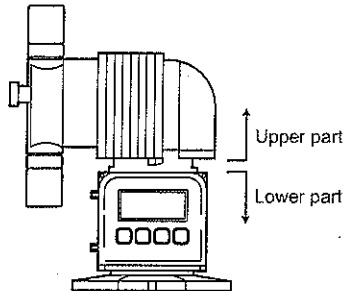

(view from above)

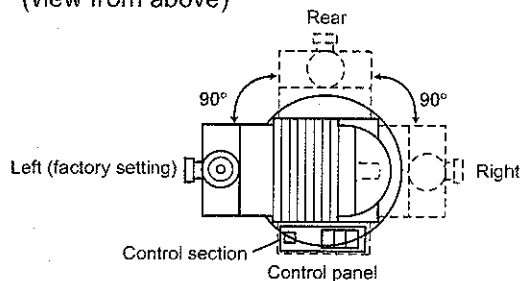

- (1) Turn the pump head/solenoid box (simply called "upper section" from here on) counterclockwise by about 30°, and lift up slightly by a few centimeters.

The mating surface is as shown in the figure below.

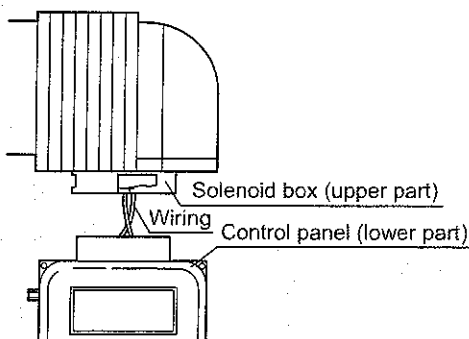
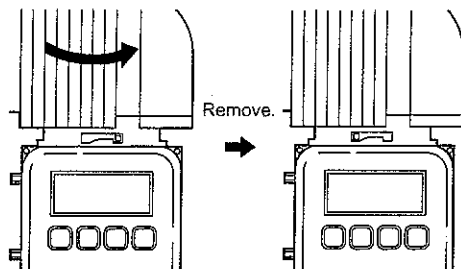

- (2) Turn the upper section, align the groove on the upper section mating surface with the protrusion on the lower section mating surface.
- (3) Turn the upper section clockwise to secure.

IMPORTANT

- The upper section and lower section are connected by electrical wiring. When lifting up the upper section, make sure that the upper section is separated from the lower section by only a few centimeters. Separating the two sections by more than this distance may cause the leads to break.
- When turning the upper section, do not apply force to the pump head, and, in particular, to hose nut section or control panel cover. Doing so might break these parts.
- The fixing section is made of plastic. Do not apply excessive force to this section. Doing so might break it.
- Prevent electrical wiring from being excessively twisted or nipped.
- The upper section is fitted onto the lower section to the left, rear, and right as you face the control panel. The upper section cannot be fitted at intermediate positions between these orientations.
- When fitting the upper section onto the lower section, firmly turn the upper section so that the protrusion is fully aligned with the groove as far as possible, and make sure that the upper section is fixed in place.

NOTE

- When turning the upper section, the upper section can be turned more easily by pressing downwards.
- Before the pump is shipped, the upper section is assembled so that the pump head faces the left as you look at the control panel.

6-3 Piping on the VEC and VFC Types

This section describes piping on the VEC and VFC types.

Differences with the CL type and the boiler specification are described from the following page onwards. Consult us for details when piping the FTC, 6TC and STC types.

6-3-1 Requests during piping

IMPORTANT

- The hose vibrates as this pump generates pulsation. Support the hose so that it does not vibrate.
- We recommend installing an air chamber to reduce pulsation. Consult your supplying agent separately for details.
- When bending the hose, allow sufficient bending margin (40 mm radius for dia. 4 x 9 mm, and dia. 6 x 11 mm hose, or 100 mm radius or more for dia. 12 x 18 mm hose in the case of a PVC braided hose) to prevent it from folding.

Prevent the hose from being folded, worn, cut, or stepped on. Failure to do so might break the hose.

- If the hose is too long, pressure loss might increase, causing the pump's permissible pressure to be exceeded and overfeed to occur. For details on overfeed, see page 34.
- To prevent the hose from becoming disconnected, fully insert it up to its specified position and firmly tighten the nut. Do not excessively tighten the nut using a tool. Doing so might break the hose.

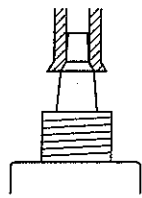

Dia. 4 mm x
dia. 9 mm hose

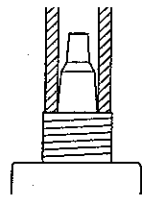

Dia. 6 mm x
dia. 1 mm hose

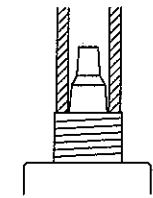

Dia. 12 mm x
dia. 18 mm hose

- The tightening force on the hose sometimes weakens if the pump is used at a location where the chemical temperature and ambient operating temperature are higher than room temperature. Tighten the nut as required at start of pump operation.
- When removing hoses and laying the same hoses during maintenance, for example, cut about 10 mm from the end of the hoses before inserting them onto the pump.
- When the control panel is splashed with chemicals, immediately turn OFF the pump, wash off the chemicals with clean running water, and allow the control panel to fully dry before restarting pump operation.
- We recommend a multi-valve and maintenance valve (boiler specification only) that allow pressure in the discharge piping to be relieved by one-touch operation during maintenance.

- We recommend installing a relief valve that allows pressure to be relieved automatically from the inside of the discharge piping.
- Install a pressure gauge for measuring the pump's discharge pressure on the discharge piping.

A total of three meters of hose is provided for the discharge and suction sides.

When extending the piping beyond this distance, pressure loss sometimes exceeds the pump's maximum discharge pressure. So, thicker piping must be provided. When extending the piping, notify your supplying agent of the viscosity of the chemicals, piping length (positional relationship), specific gravity of the chemicals, and other information. Your supplying agent will select the ideal piping services for you.

6-3-2 Anti siphonal check valve

This pump is provided with an anti siphonal check valve.

Use this valve in the following instances:

- (1) When chemicals are injected with the injection point open to air and at a point lower than the fluid level in the chemical tank (See Preventing Siphoning, page 34.)
- (2) When chemicals are injected into suction piping on other centrifugal pumps
- (3) When an excessively large amount of chemicals beyond the rated discharge volume flow

NOTE

- Overfeed may occur if the piping is too long on the rise piping. For details on overfeed, see page 34.

6-3-3 Installing the anti siphonal check valve

- (1) Provide an Rc1/2 female screw section at the injection point. The anti siphonal check valve is already threaded for a R1/2 male screw.

NOTE

- The 32/52 model also supports R3/8 screws. The shape of these screws is also different.

- (2) Screw the seal tape into the male screw section on the anti siphonal check valve. If the screw is difficult to screw in, hold the nozzle grip with pliers or other tool, and gently tighten.

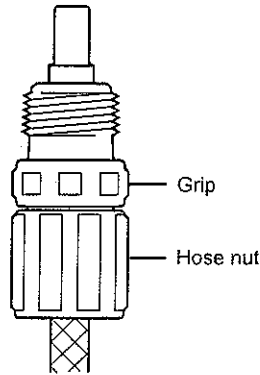

- (3) When the hose is attached with the anti siphonal check valve attached to the main piping, be sure to turn the hose nut by its grip. Otherwise, the screw section or other parts of the nozzle may be damaged.

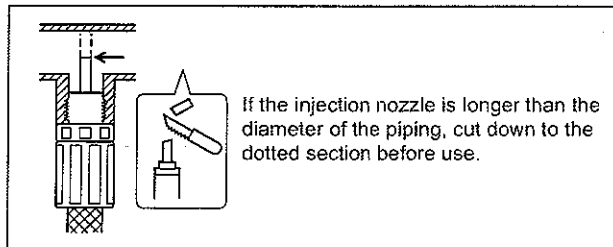

- (4) When injecting chemicals into fine piping, cut the tip of the injection nozzle to an appropriate length before use. Cut the nozzle to an appropriate length so that its tip is located in the center of the piping to carry the injected chemical.

IMPORTANT

- We recommend mounting the pump via the anti siphonal check valve for maintenance. Provide an Rc1/2 female screw section and screw in. Use a valve of material that resists the chemical in use.

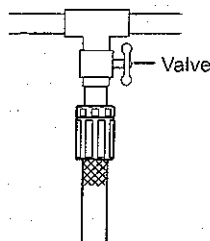

6-3-4 Suction piping

IMPORTANT

- Install the pump as close as possible to the chemical tank.
- If the suction piping is too long, cavitation may occur and metering performance may no longer be ensured. See Cavitation, page 34.
- Avoid using piping with bends or joints that might cause resistance in chemical flow.
- Be sure to connect the foot valve (provided) to the end of the suction side hose, and prevent the inflow of dirt or foreign objects into the pump head or valve seat.

6-3-5 Installing onto a TACMINA tank

(when using the optional multi-valve)

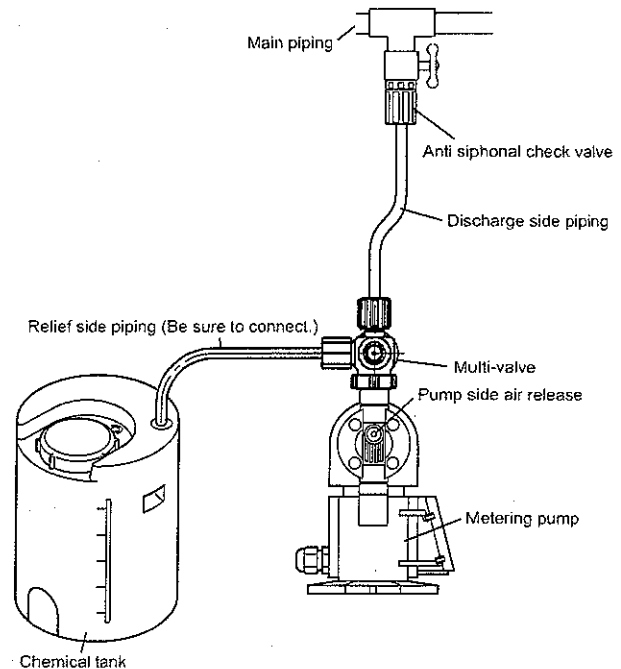

(when installed on the floor)

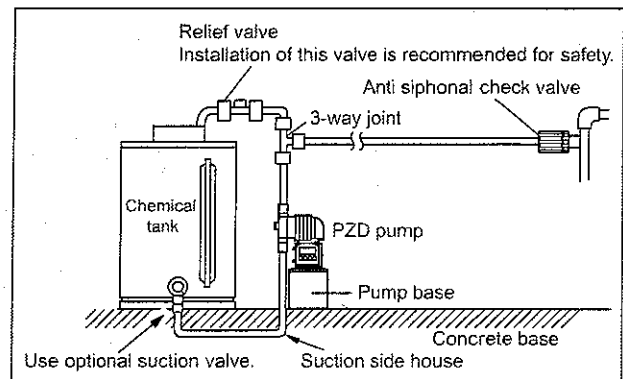

- (1) Pass the hose through the hose nut and connect to the suction valve on the tank. Next, connect the hose to the joint on the pump's suction side in the same way.
- (2) Pass the discharge side hose through the hose nut, and connect the hose to the joint on the pump's discharge side. Next, attach the anti siphonal check valve to the injection point, and then connect the discharge side hose.

(when installed on the tank)

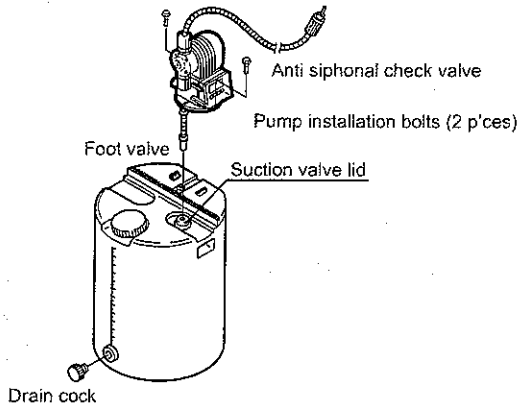

- (1) Fasten the pump at the specified position on the top surface of the tank with the mounting bolts (provided).
- (2) Pass the hose through the hose nut, attach the foot valve, and determinate the mounting dimensions so that the foot valve is 30 mm or more from the tank bottom. Then, pass the suction pipe lid and hose nut through along the hose, and connect to the joint on the pump's suction side.
- (3) Tighten the suction pipe lid.
- (4) Pass the discharge side hose through the hose nut, and connect to the hose joint on the pump.
- (5) Attach the anti siphonal check valve to the injection point, and connect to the discharge side hose.

IMPORTANT

- We do not recommend installing the pump above the tank when using chemicals that are likely to generate bubbles.
- The suction height on this pump is -1.5 m. Suction performance may drop if the pump head's valve seat dries up.

6-4 Hose Piping When Injecting Sodium Hypochlorite on the CL Type

6-4-1 Piping request

IMPORTANT

- Use push-in piping (installing below the tank position). This makes it harder for gas lock and other trouble to occur.
- Make the piping (hose) as short as possible. This reduces the amount of gas that occurs and accumulates in the piping, and makes it harder for gas lock to occur.
- Do not lay piping above pathways. Also, prevent chemicals from splashing personnel if hoses are damaged.
- We recommend providing a washing water line in the piping.

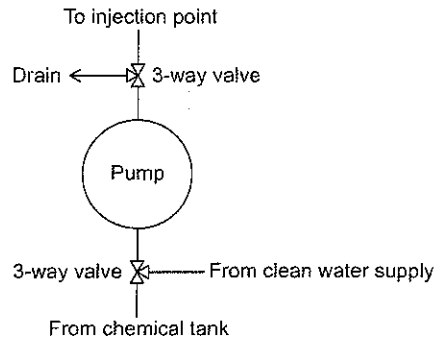

6-4-2 Recommended piping examples

(1) Suction side

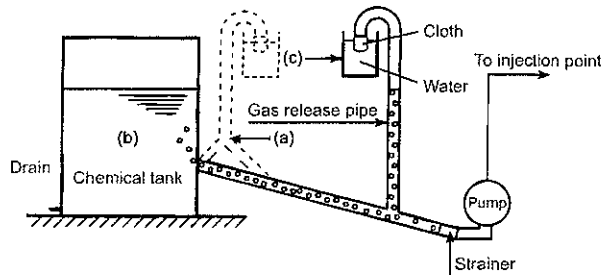

- (a) If dilution is possible using only underground water containing iron such as in mountainous districts, for example, measures for preventing the entry of slurry into the piping are required.
- (b) Take measures to fully use the entire content in as short a period as possible (in particular, about 10 to 20 days in summer).
- (c) It is also important that corrosion is not caused in the surrounding environment. In this case, treat gas containing available chlorine by water or with a cloth containing reducing agent.

(2) Discharge side

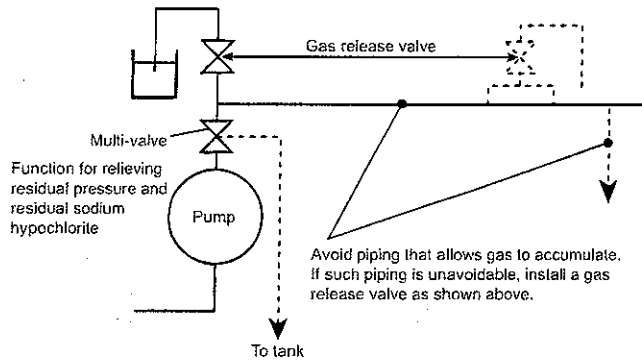

6-4-3 Attaching the anti siphonal check valve

- A black check cap is screwed onto the nozzle tip. Make sure that this part is not loose. Be sure to use the valve with the check cap attached.

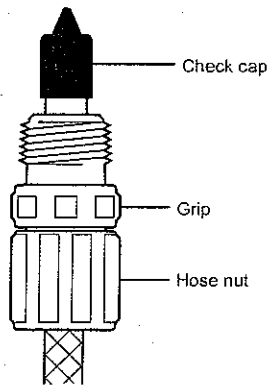

6-5 Piping on Boiler Specification Models

6-5-1 Discharge side

- (1) A 2 m nylon tube is provided for discharge. Install the chemical pump as close as possible to the injection point, and cut off any surplus hose.
- (2) Attach the tube as follows.

1. Cutting the tube

Cut the tube vertically along the axial direction using a sharp knife.

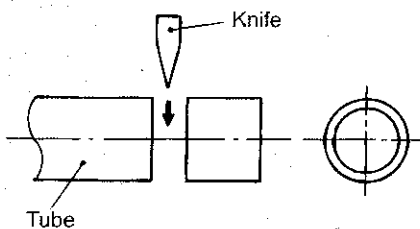

2. Inserting the tube

Insert the tube straight against the body of the push-one joint fitting until its tip touches the innermost side. Lightly pull the tube to make sure that the tube does not become disconnected.

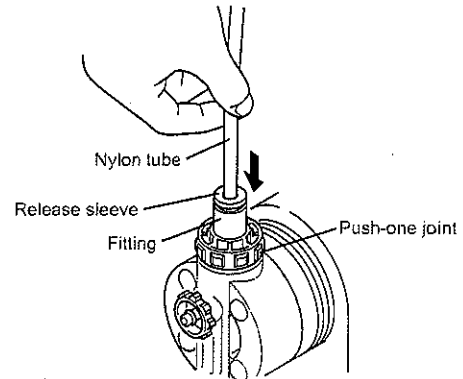

3. Removing/re-attaching the tube

Pull the tube away straight without twisting it with the release sleeve pressed evenly against the body with both fingers. When re-attaching the tube, repeat step (2) above after cutting the damaged section on the tip of the tube.

If you find it difficult to remove the tube, the claw on the fitting might be biting deeply into the tube. If this happens, firmly press down the release sleeve using a spanner or other tool

IMPORTANT

- Limit the number of tube removals and re-attachments to five times. When the push-one joint is used beyond this limit, lightly pull the tube upwards with the tube inserted to fully make sure that it is fixed in place. (Confirm this also each time the joint is used when it is used for less number of times.) If the tube appears to become disconnected, the claw on the joint might be damaged. Replace the joint. Use the provided tube. Other tubes may damage the joint.

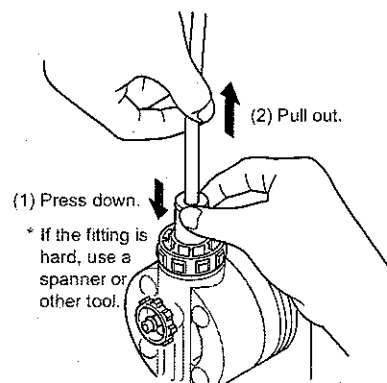

- When attaching or removing the tube, be sure that the inside of the piping is in a non-pressurized state.
- We recommend installing a maintenance valve (boiler specification only) capable of releasing the pressure of the discharge piping by one-touch operation during maintenance.

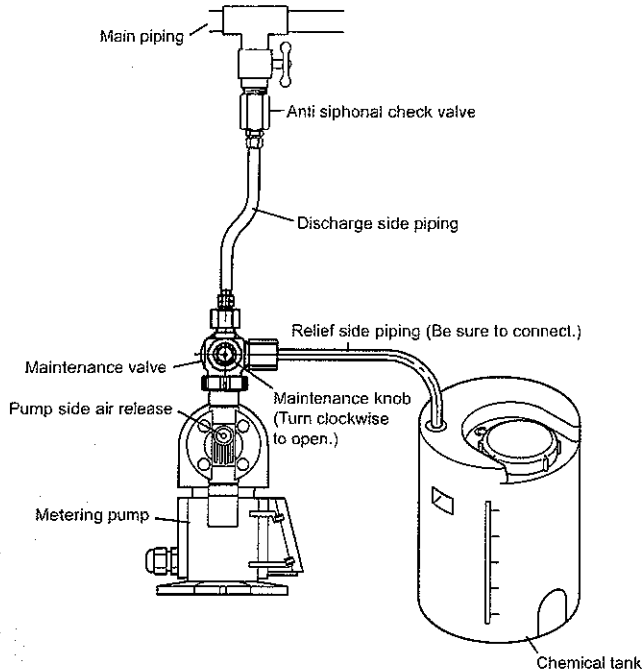

6-5-2 Straight check valve for boilers

The straight check valve for boilers is exclusively for connection by a nylon tube.

(1) Attachment method

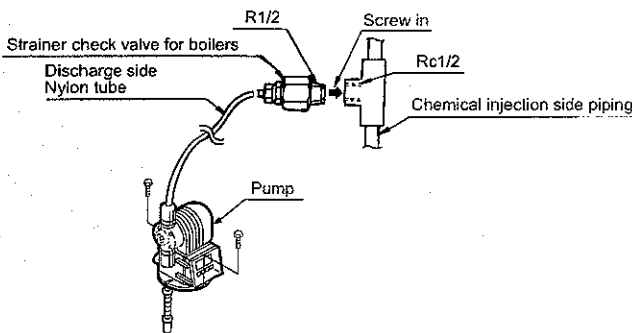

- (2) The straight check valve for boilers is already threaded for a R1/2 male screw. Joint the Rc1/2 screw to the injection point.
- (3) To attach the nylon tube, fix the main unit in place, return the nut counterclockwise by about one half turn, and make sure that the nut is loose. Next, firmly insert the tube until its tip is contacting the groove on the innermost side of the main unit, and tighten the nut as far as possible in this state by manually turning it. Finally, tighten it a few turns using a monkey wrench or spanner.

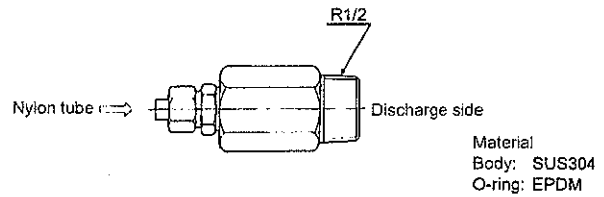
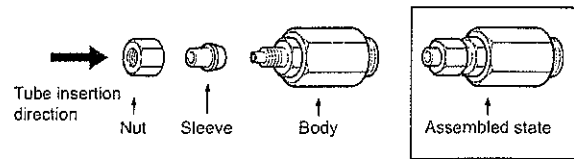

IMPORTANT

- Firmly make the connection between the nylon tube and check valve, and check valve and injection port.
- The check valve cannot be used as it may corrode depending on the chemical used. When using special chemicals, consult your supplying agent separately for details.

6-6 Piping on the ARPZD-CL (PZD w/ automatic air release)

6-6-1 Piping request

Be sure to pipe the air release hose, and return the tip of the hose to the chemical tank.

IMPORTANT

- The self-suction height of this pump is -0.5 m, so the pump sometimes cannot suck in fluids if the fluid level is low.
- The ARPZD differs from the PZD and general metering pumps. Note that on the ARPZD the front of the pump head is the discharge side, and the top of the pump head is the air release side.

ARPZD

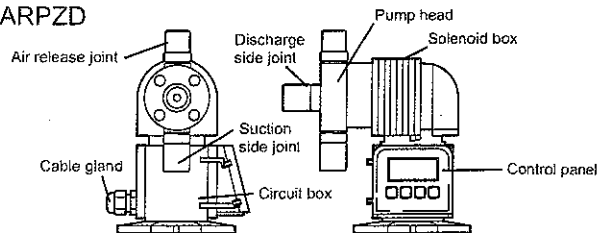

- Use push-in piping (when installed on the floor) and make the hose as short as possible. This reduces the amount of gas that occurs and accumulates in the piping, and makes it harder for gas lock to occur.

- Do not lay piping above pathways. Also, prevent chemicals from splashing personnel if hoses are damaged.
- We recommend providing a washing water line in the piping.

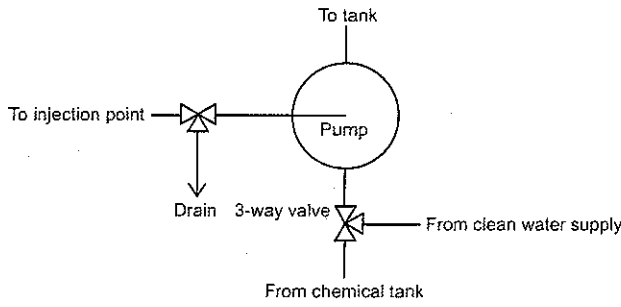

6-6-2 Examples of recommended piping

(1) Suction side

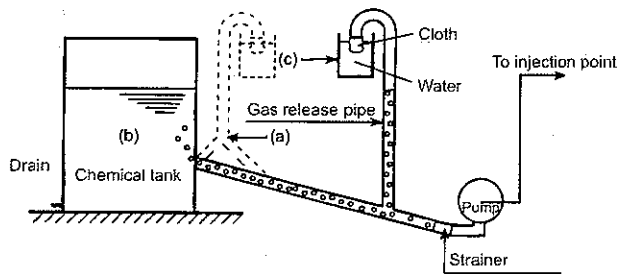

- If dilution is possible using only underground water containing iron such as in mountainous districts, for example, measures for preventing the entry of slurry into the piping are required.
- Take measures to fully use the entire content in as short a period as possible (in particular, about 10 to 20 days in summer).
- It is also important that corrosion is not caused in the surrounding environment. In this case, treat gas containing available chlorine by water or with a cloth containing reducing agent.

(2) Discharge side

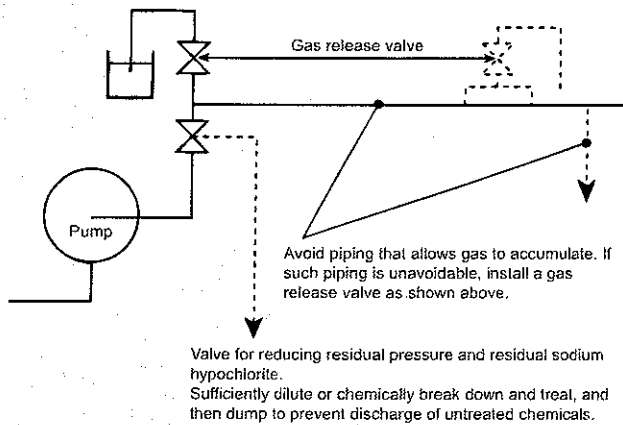

6-6-3 Attaching the anti siphonal check valve

- A black check cap is screwed onto the nozzle tip. Make sure that this part is not loose. Be sure to use the valve with the check cap attached.

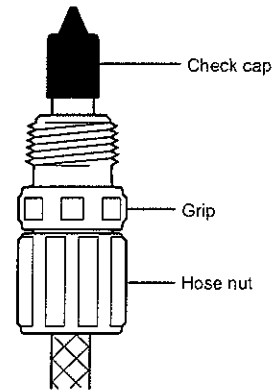

6-6-4 Installing onto a TACMINA tank

(when installed on the floor)

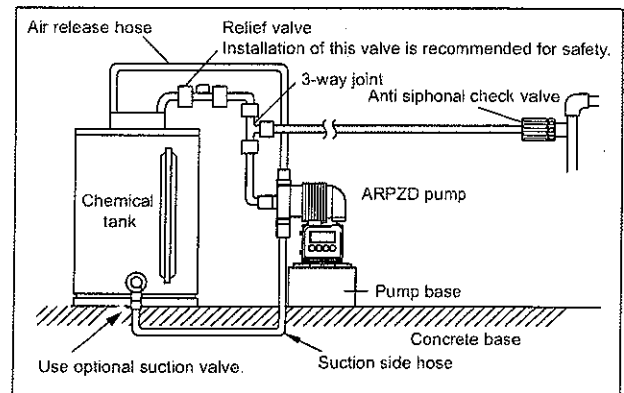

IMPORTANT

- Install the pump as close as possible to the chemical tank.

7 Electrical Wiring

7-1 Connecting the Power Supply and Ground Leads (connections common to all PZD types)



- Do not operate the pump with wet hands. Doing so might cause an electric shock.
- Do not turn the power ON during electrical wiring. Attach a "Work In Progress" label to the power switch.
- Do not disassemble the main unit or circuits.

- (1) The AC power connection is a 3-pin separate type connector. (including ground)
Use 2mm² round tough-rubber sheath cable as the cable. (Use VCTF-4C, and cut one cable.)



- The cable gland can accommodate tough-rubber sheath cable of O.D. 5 to 10 mm.
- Be sure to use a commercial power supply (power supply provided by power company or equivalent power supply).
- Unusable Power Supplies
 1. Power supply provided with an AC power regulator
 2. Power supply on inverter output

- (2) Follow the procedure below to wire the electrical wiring.

1. Loosen the four screws from the rear of the circuit box, and open the cover.
2. Draw out the separate type connector.

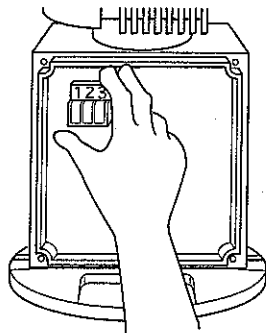

3. Strip back the outer sheathing from the core lead by about 10 mm.

4. Insert the lead into the hole on the connector, and tighten firmly with a regular screwdriver.
5. Lightly pull to make sure that the lead does not become disconnected.
6. Put the connector back to its original position, and fasten the cover with screws.

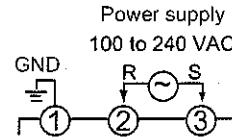

Power Supply Connection

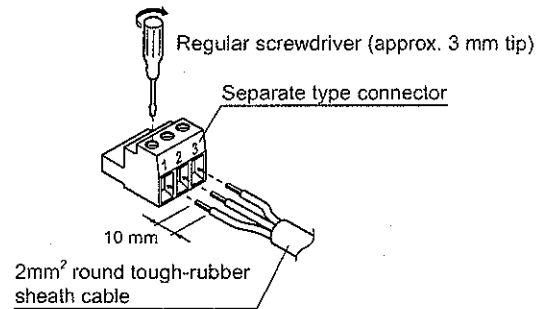

- (3) Wiring method (typical wiring example)

- Standalone operation

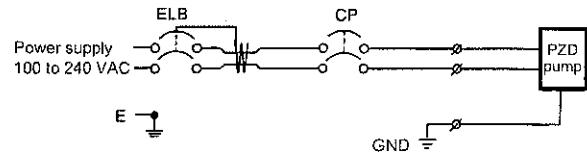

- Operation interlocked with a transfer pump

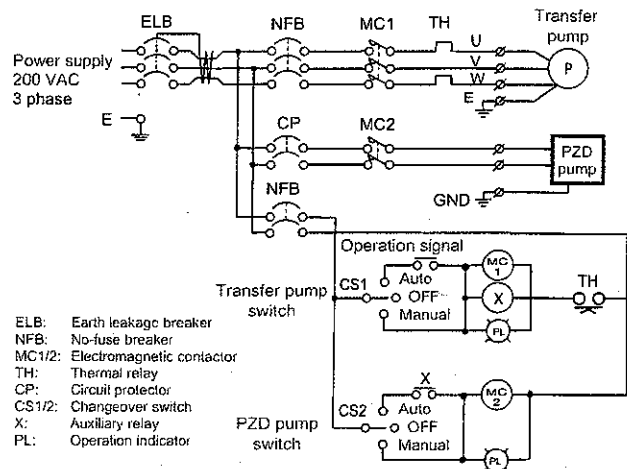

- ELB: Earth leakage breaker
- NFB: No-fuse breaker
- MC1/2: Electromagnetic contactor
- TH: Thermal relay
- CP: Circuit protector
- CS1/2: Changeover switch
- X: Auxiliary relay
- PL: Operation indicator

IMPORTANT

- Do not take the power from the same terminal as the induction motor of the transfer pump, for example.

High voltage may be generated when the power is cut OFF, resulting in malfunction.

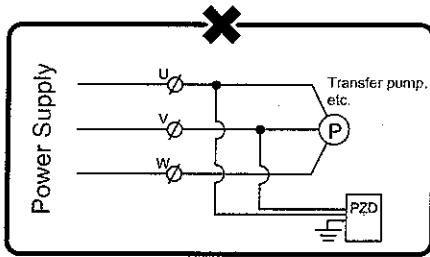

NOTE

- A circuit protector (CP) is ideal as an overcurrent protective device on the PZD pump from the point of view of operating time and interrupted current characteristics.
- The circuit protector indicated in 7.2 Recommended Protective Devices can be used as a switch for the power supply. This helps simplify wiring.
- From the point of view of characteristics, a thermal relay for a motor is inappropriate for protecting the PZD pump.

7-2 Recommended Protective Devices

(1) Circuit protector

(This protects the main power supply when the PZD pump malfunctions.)

	PZD-31/61/12 model ARPZD-31/61/12 model	PZD-32/52 model
Mitsubishi Electric Corporation	CP-30-BA2P1-M3A	CP30-BA2P1-M5A
Fuji Electric Co., Ltd.	CP32D/3	CP32D/5
Matsushita Electric Works, Ltd.	BAC201305	BAC20 1505

(2) Arrester

Use an arrester that is matched to the power supply in use. The following table shows recommended arresters for a 100 V and 200 V power supply.

Manufacturer	Model
	For power supply
M-System Co., Ltd.	MA-100 (for 100 VAC)
	MA-200 (for 200 VAC)

(3) Line filter, shielded transformer

Manufacturer	Model
TDK Corporation	Noise filter ZMB2202-11
AIHARA ELECTRIC CO., LTD.	Shielded transformer SPB-300E

(4) EMC filter

Manufacturer	Model
TDK Corporation	ZAC2205-00U

8 Operation

WARNING

- When handling chemicals, be sure to use protective apparatus (rubber gloves, face mask, protective goggles, chemical-resistant work clothes, etc.) matched to the chemicals you are using.
- When the pump is connected via a valve, do not operate the pump with the valve closed. Doing so might cause high pressure inside the pump or the discharge piping, causing fluid to spray out or equipment to malfunction.

IMPORTANT

- If the control panel is splashed with chemicals, immediately wash the chemicals off the control panel with clean water. If the control panel is left as it is, chemical might enter inside the circuits and cause them to malfunction if the chemicals is a highly penetrating type.

8-1 Preparing for Operation

Check the following as preparations for operation:

- (1) Make sure that there are sufficient chemicals remaining in the chemical tank. Replenish the chemical tank if necessary.
- (2) Check the piping line for any disconnections, fluid leakages caused by damage to piping, and blockages.
- (3) Make sure that the valves on the suction and discharge piping are open.
- (4) Make sure that the pump is connected correctly to the specified power supply.
- (5) Inspect the electrical wiring for any wrong connections and for the danger of short circuits and electrical leakage.

8-2 Releasing Air

WARNING

- During air release, chemicals spray forcefully from the tip of the air release valve. Be sure to attach the air release hose and return chemicals to the tank.

IMPORTANT

- When the pump is used for the first time, or when the chemical tank has been replaced, be sure to release air before starting pump operation.

NOTE

- The PZD-32/52 is not provided with an air release function.

8-2-1 Air release procedure (PZD-31/61/12-VEC/VFC/CL)

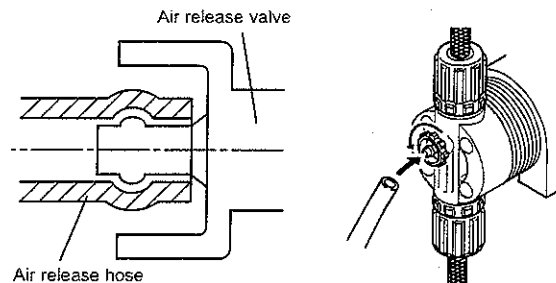

- (1) Insert the air release hose (dia. 4 mm x dia. 6 mm) (provided) into the tip of the air release valve making sure that it is inserted as far as possible down to its base.

Return the other end of the hose to the chemical tank, for example.



- (2) Turn the pump ON, set the stroke number to 300 spm (100% or maximum discharge volume), and press the START button.

NOTE

- The default discharge volume is 300 spm.
- When the pump discharge volume has been changed, simultaneously press the  and  keys. This operates the pump at 300 spm to quickly release air.

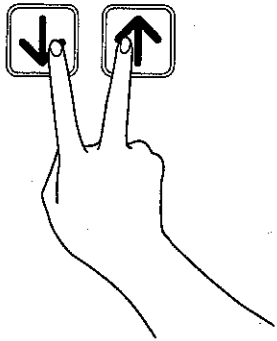



- (3) Turn the air release valve about 1 to 1.5 turns counterclockwise while operating the pump.

Any residual air in the suction side hose or pump head is discharged from the air release valve, and the pump head is filled with chemical. Tighten the air release valve as chemical is forced out during this operation.

8-2-2 Air release procedure (PZD-32/52 model)

- (1) Relieve pressure from the discharge piping.
- (2) Adjust the scale on the stroke length adjusting dial on the rear of the solenoid box to 100%.
- (3) Turn the pump ON, set the stroke number to 300 spm (100% or maximum discharge volume), and press the START button.

The pump can be operated at 300 spm by simultaneously pressing the  and  keys in this step.

8-2-3 Air release procedure (PZD-31/61/12-FTC, 6TC)

- (1) Turn the pump OFF, and then relieve the pressure from the discharge piping.
- (2) Turn the air release cock at the bottom right of the pump head counterclockwise to slightly loosen the cock. Operate the hose pump (provided) with it held tightly against the cock to suck chemicals up to the pump head.

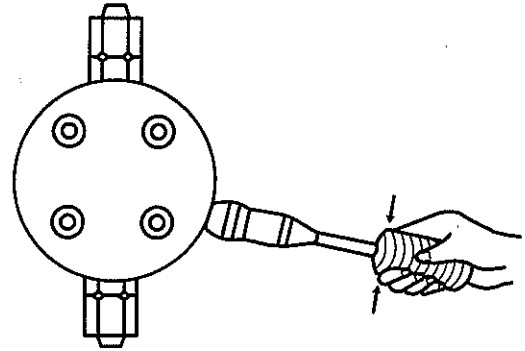

IMPORTANT

- Take care not to excessively loosen the air release cock. If it becomes disconnected, the packing may be damaged.

- (3) Turn the pump ON, set the stroke number to 300 spm (100% or maximum discharge volume), and press the START button.

8-2-4 Chemicals are not sucked up even by releasing air

Dirt sometimes bites into the valve seat (part where the check ball forms a seal) on the discharge or suction sides. Turn the pump OFF, remove the joint, and wash the check ball and valve seat with clean water. Next, fit the check ball and valve seat into the pump head again in a wet state making sure not to mistake the discharge and suction sides.

8-3 Control Panel

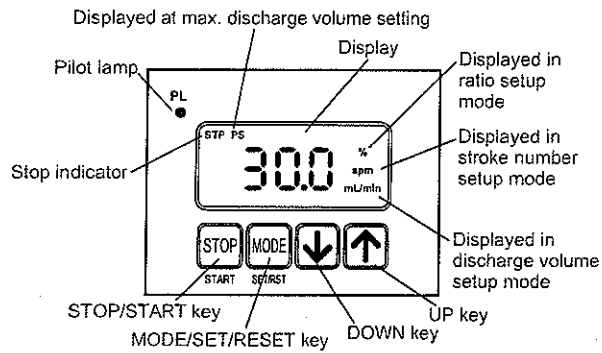

8-3-1 Adjusting the stroke length on PZD-32/52 models

On the PZD-32/52 models, the stroke length of the diaphragm can be adjusted within the range 20% to 100% by turning the stroke length adjusting dial on the rear of the solenoid box.

If the stroke length adjusting dial is adjusted while the pump has stopped, the stroke scale may move out of position during pump operation. If this happens, fine-adjust again.

IMPORTANT

- The description at the item for adjusting the discharge volume assumes a stroke length of 100%. If the stroke length has been changed, reduce the maximum discharge volume and the discharge volume per stroke by the same ratio.
- When adjusting the discharge volume, mainly adjust by the stroke number, and adjust by the stroke length only as an auxiliary measure (e.g. for fine adjustment). As far as possible, operate the pump at a stroke length of 100%.
- Do not set the stroke length within the range 0 to 20%.

8-4 Setting the Discharge Volume

The discharge volume on this pump can be set in one of three ways: by stroke number (1 to 300 spm), ratio (1 to 100%), and discharge volume (0.1 to maximum discharge volume mL/min).

IMPORTANT

- In descriptions from here on, keys having two or more functions are indicated by the name of the required function.

(Example)

To operate the pumpSTART key
(START/STOP key)

To apply a setting valueSET key
(MODE/SET/RST key)

Basic Method of Use (When using the pump in other modes, read the pages following this page.)

Setting the Discharge Volume (stroke number setup mode)

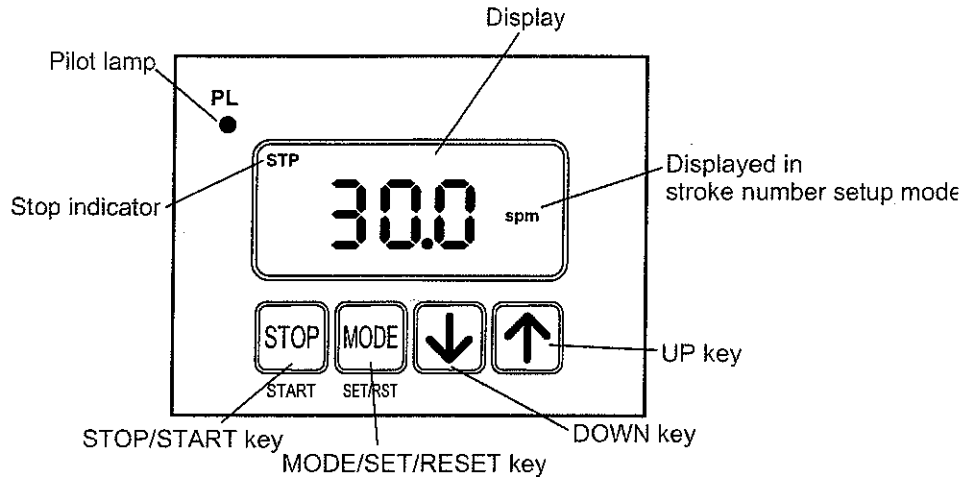

8-4-1 Setting the discharge volume (stroke number setup mode)

This is the default setup mode.

- (1) Check the maximum discharge volume of the pump.
- (2) Calculate the stroke number to be set from the required discharge volume.

$$\text{Stroke number setting (spm)} = \frac{\text{required discharge volume (mL/min)}}{\text{maximum discharge volume of pump (mL/min)}} \times 300 \text{ (spm)}$$

- (3) Check the pump operating mode.



- "spm" is displayed on the right side of the screen in the stroke number setup mode.
- "STP" is displayed if the pump has stopped.

- (4) If the pump is in another mode, press the **STOP** key to stop pump operation.
- (5) Press the **MODE** key several times to set the "spm" unit display.



- (6) Press the **↓** **↑** keys to change to the stroke number calculated in step (2).

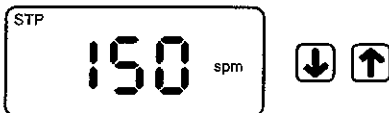

- (7) The new stroke number setting is stored to memory.
- (8) Press the **STOP/START** key to start pump operation.

NOTE

- The setting value can be also be changed during pump operation by pressing the **↓** **↑** keys.
- To ensure a more accurate discharge volume, operate the pump for one minute not at the "maximum discharge volume of the pump" as indicated in the specifications but at 300 spm in an actual piping state, and calculate based upon the discharge volume (or the volume sucked in by the pump).
→ See [Calibration] under "8-4-5 Discharge volume setup mode" on page 18.

8-4-2 Setup modes

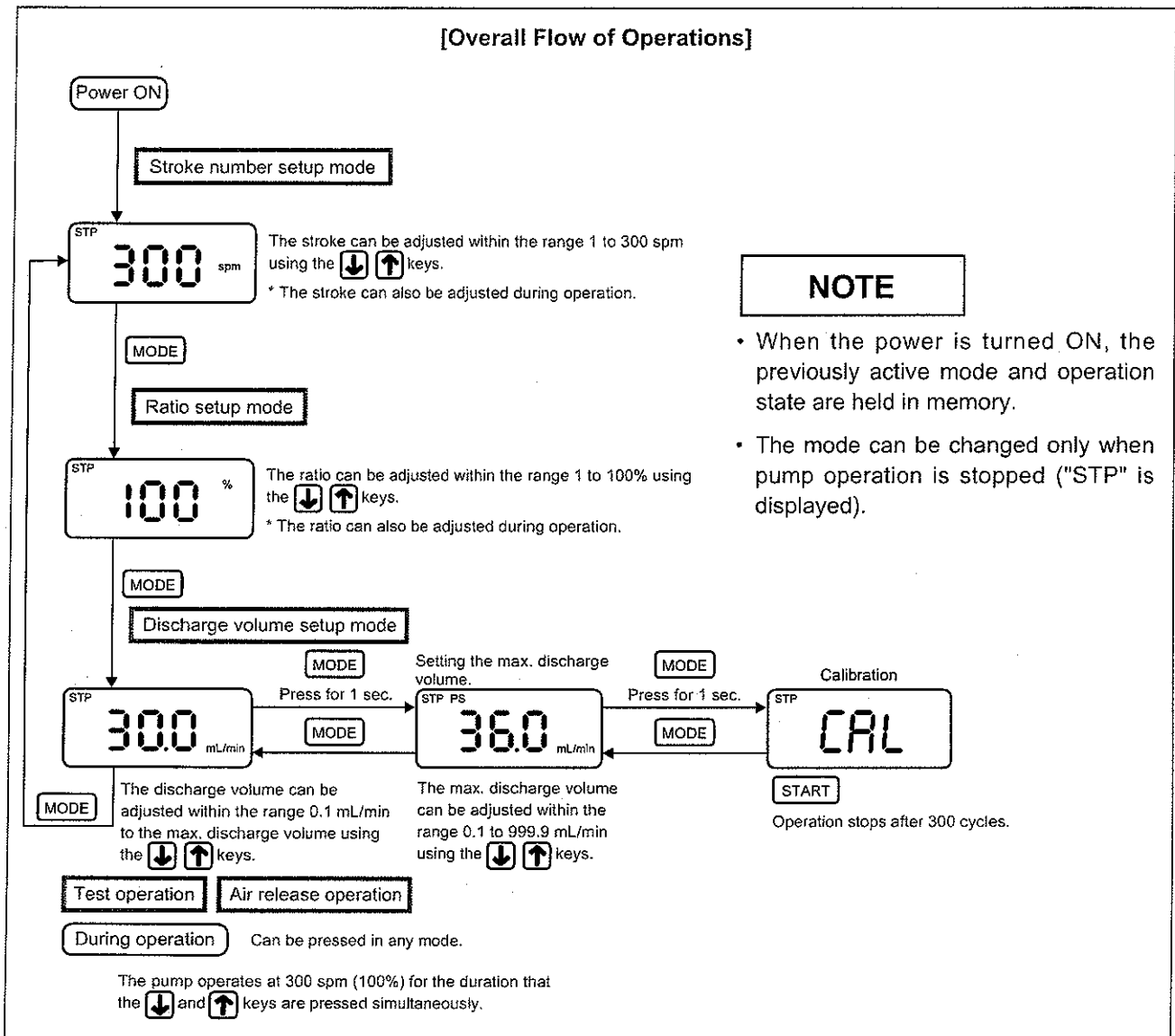

NOTE

- When the power is turned ON, the previously active mode and operation state are held in memory.
- The mode can be changed only when pump operation is stopped ("STP" is displayed).

8-4-3 Number of strokes setup mode

- (1) Press the **MODE** key to set the "spm" unit display.

(This is the default.) If the pump is operating, first press the **STOP** key to stop pump operation.



- (2) Change the stroke number (spm) by the **↓** **↑** keys.

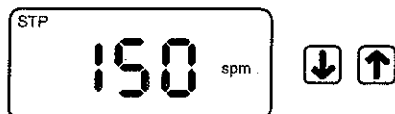

- (3) Press the **START** key to start pump operation.

8-4-4 Ratio setup mode

In this mode, the stroke number are set as a ratio (%) taking the maximum stroke number (300 spm) as 100%.

- (1) Press the **MODE** key to set the "spm" unit display.

If the pump is operating, first press the **STOP** key to stop pump operation.

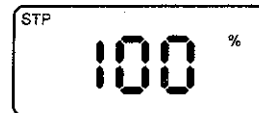

- (2) Change the ratio (%) by the **↓** **↑** keys.

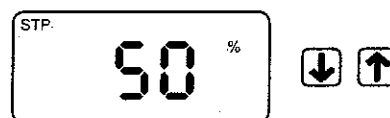

- (3) Press the **START** key to start pump operation.

8-4-5 Discharge volume setup mode

This mode is for directly setting the required discharge volume.

In this mode, first measure the discharge volume under the piping conditions (300 spm) in use, and store the maximum discharge volume to memory. (This is "calibration.") From here on, if the required discharge volume is set, the pump operates at a converted speed.

IMPORTANT

- The correct discharge volume is set by measuring the maximum discharge volume under actual piping conditions, and storing this value to memory.

[Calibration]

- (1) Install the pump and piping matched to actual piping conditions, and set the pump ready for operation.
- (2) Pour the chemical to be actually used into a weighing utensil such as a graduated cylinder capable of measuring the maximum discharge volume for one minute of pump operation.
- (3) Insert the pump suction piping into the graduated cylinder, and release air.
* Providing measurement piping on the chemical tank comes in useful.
- (4) On 32/52 models, set the stroke length to the actually used setting. After setting the maximum discharge volume, do not change the stroke length.
- (5) Press the **MODE** key several times to set the "spm" unit display. If the pump is operating, first press the **STOP** key to stop pump operation.



- (6) Holding the **MODE** key down for one second longer displays the maximum discharge volume setting screen*.
Holding the **MODE** key down for a further one second, sets the pump to the calibration mode.



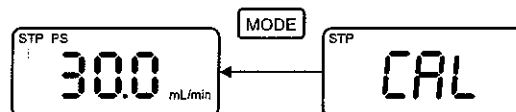

- (7) Note down the fluid level of the graduated cylinder.
- (8) Pressing the **START** key operates the pump for one minute (300 cycles) after which pump operation stops. During pump operation, "CAL" blinks.
- (9) Check the fluid level of the graduated cylinder, and measure the drop in chemical level.
- (10) Press the **MODE** key to redisplay the maximum discharge volume setting screen.



- (11) Set to the value calculated in step (9) by the **↓** **↑** keys.
- (12) Press the **MODE** key. This redisplay the discharge volume setting screen.

NOTE

- When the discharge volume setting screen is redisplayed, the discharge volume setting value will not appear changed. However, the actual stroke number setting of the pump has been changed.



(13) The discharge volume can be set by the   keys.

(14) Turn the power OFF, and restore the piping.

[Setting the discharge volume] * Use this item after performing calibration.

- (1) Press the **MODE** key to set the "mL/min" unit display. If the pump is operating, first press the **STOP** key to stop pump operation.



(2) Set the required discharge volume by the   keys.

(3) Press the **START** key to start pump operation.

IMPORTANT

- Use this mode after performing calibration.

NOTE

- The discharge volume setting value cannot exceed the maximum discharge volume setting value that has been entered after entering the calibration mode.

8-5 Stopping Operation for an Extended Period

- (1) Suck clean water or cleaning solution into the pump for about 30 minutes, and discharge to clean the inside of the pump head.
- (2) After sufficiently cleaning the inside of the pump head, completely turn the power OFF.
- (3) Cover the pump with the protective cover to protect first from accumulating on the pump and protect the pump from corrosive atmospheres.

8-6 Preparations for Restarting Operation

- (1) Make sure that there are sufficient chemicals in the chemical tank. Replenish the chemical tank if necessary.
- (2) Check the inside of the chemical tank for accumulated sediment or any other abnormalities such as clouding. If the quality of the chemicals has deteriorated, clean the inside of the tank, and completely replace with new chemicals.
- (3) Check the piping line for any disconnections, fluid leakages caused by damage to piping, and blockages.
- (4) Make sure that the valves on the suction and discharge piping are open.
- (5) Make sure that the pump is connected correctly to the specified power supply.
- (6) Inspect the electrical wiring for any wrong connections and for the danger of short circuits and electrical leakage.
- (7) In particular, inspect the check balls and valve seats, and make sure that they are free of dirt.

9 Maintenance and Inspection

WARNING

- Do not turn the power ON during maintenance and inspection. Attach a "Work In Progress" label to the power switch.
- Do not perform maintenance and inspection with wet hands. Doing so might cause an electric shock.
- Before loosening or removing the discharge hose or piping connections during inspection, first relieve the pressure from the discharge piping and drain the chemicals. When performing inspection, be sure to use protective apparatus (rubber gloves, face mask, protective goggles, chemical-resistant work clothes, etc.) matched to the chemicals you are using.
- Before disassembling connecting parts, relieve the pressure from the discharge piping, drain chemicals at connecting parts, and clean.

IMPORTANT

- Inspect the inside of the tank, joints, and other parts at least once every three months. When the pump is being operated 24 hours per day, inspect about once every month.
- We recommend retaining spare consumables (diaphragms, ball stoppers, check balls, etc.) so that parts can be replaced or repaired easily at any time.

9-1 Inspection during Operation (daily inspection)

- (1) Check the remaining chemicals in the chemical tank. Replenish the chemical tank if necessary.

Pay particular attention to the remaining amount of chemicals in the chemical tank when using the pump for chemicals or processes that will be compromised by entry of air.

- (2) If chemicals are leaking from the hole at the bottom of the solenoid box, immediately inspect the pump as the diaphragm might be broken.

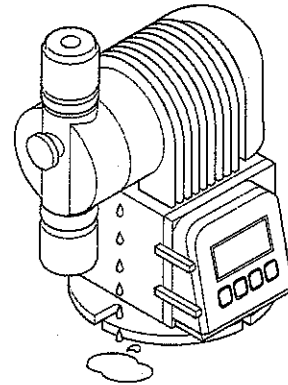

- (3) Check joints and other connections for chemical leakage. If chemicals are leaking, tighten the leaking part. If this does not stop the chemical leak, inspect the O-rings installed at each part, and replace any defective O-rings.
- (4) Make sure that the needle on the pressure gauge for measuring the pump's discharge pressure is at the correct position.

9-2 Replacing the Valve Seat and Check Ball

IMPORTANT

- Attach O-rings, ball stoppers, and check balls make sure that they face the right way.
- Prepare the "Parts Kit" that includes diaphragms, valve seats, and other consumables, and the valve seat set that includes valve seat parts.

PZD-31/61/12 model

VEC, VFC type

PZD-31 model
Boiler specification

CL type

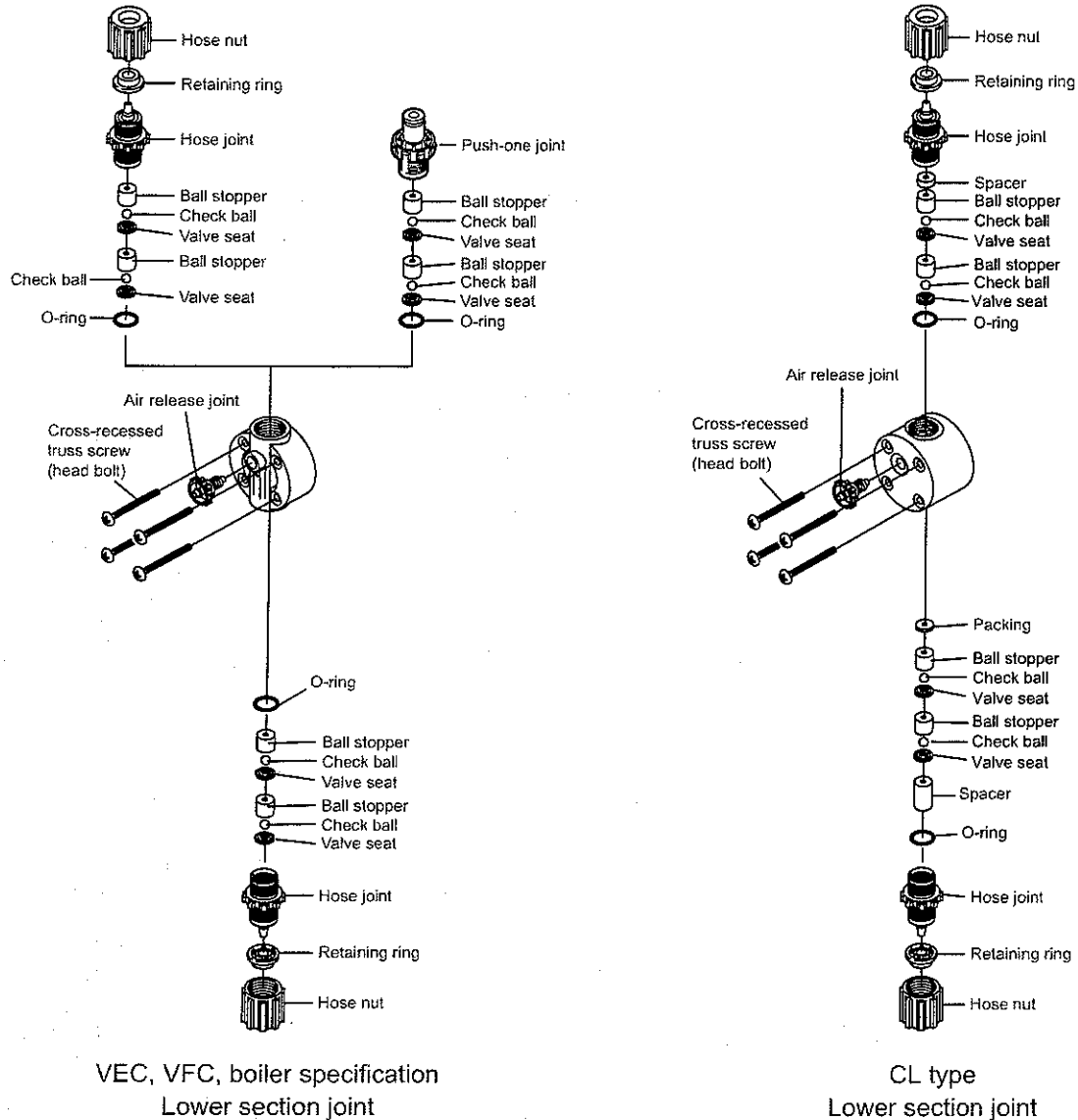

VEC, VFC, boiler specification
Lower section joint

CL type
Lower section joint

* The shape of parts differ in the case of the FTC and 6TC.

- (1) When removing and re-attaching the upper and lower sections, take care not to mistake the upper and lower joints.
- (2) Check the O-rings and check balls for scratches, or the valve seats for scratches or adhesion of dirt.

PZD-32/52 model

VEC, VFC type

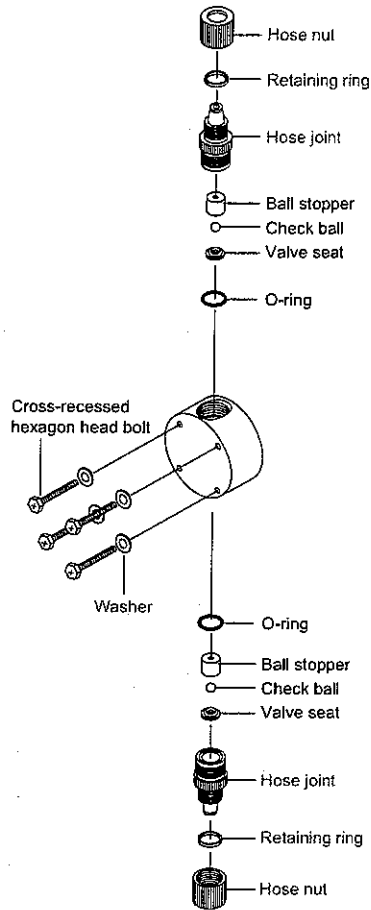

ARPZD-31/61/12

CL type

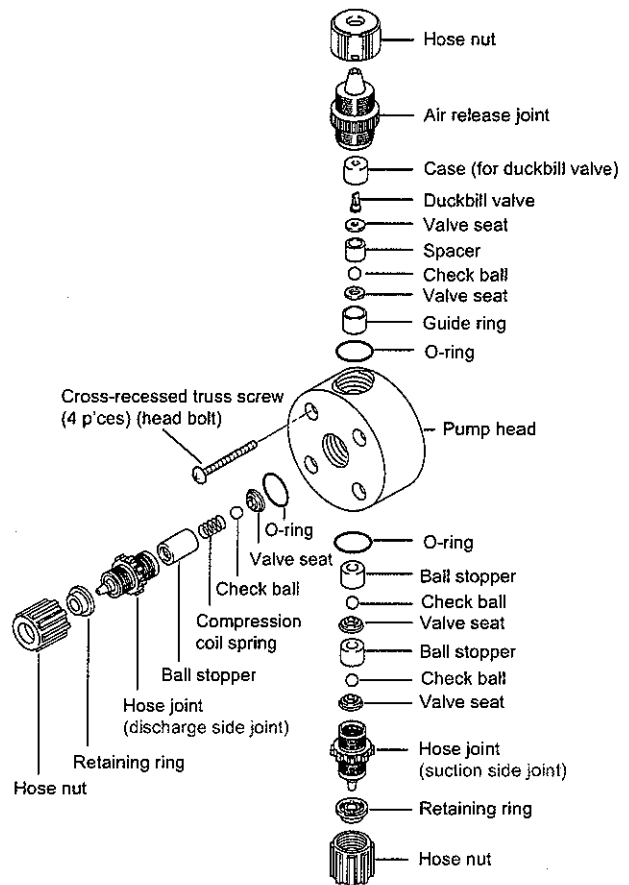

* The shape of parts differ in the case of the FTC and STC.

9-3 Replacing the Pump Head

(1) Remove the four head bolts, and remove the pump head together with the joints.

IMPORTANT

- When fixing the pump head using the head bolts, tighten the bolts in the order shown below a little at a time using even force. For example, tightening will be uneven if the bolts are tightened in the order 1, 3, 2, and 4. This might cause chemicals to leak from the pump head.

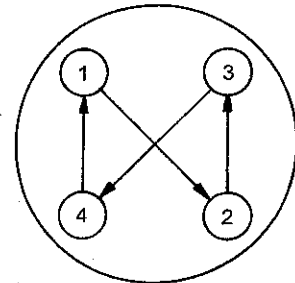

9-4 Replacing the Diaphragm (including the protective diaphragm)

- (1) Remove the pump head by following the description in 9-3.
- (2) When the pump head is removed, the diaphragm can be accessed.

Remove the diaphragm by gripping its outer periphery and turning counterclockwise.

PZD-31/61/12 model
ARPZD-31/61/12 model

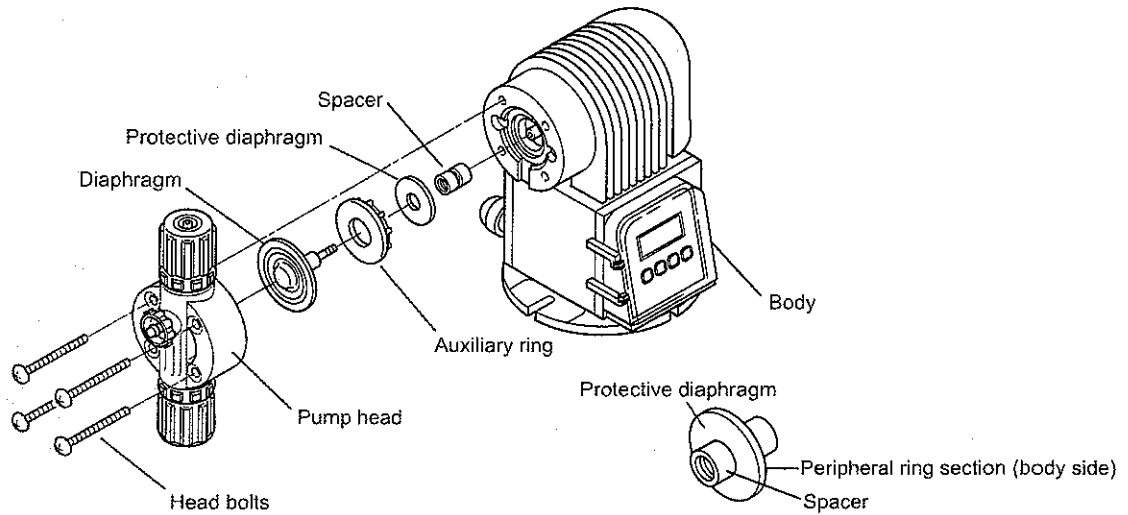

PZD-32/52 model

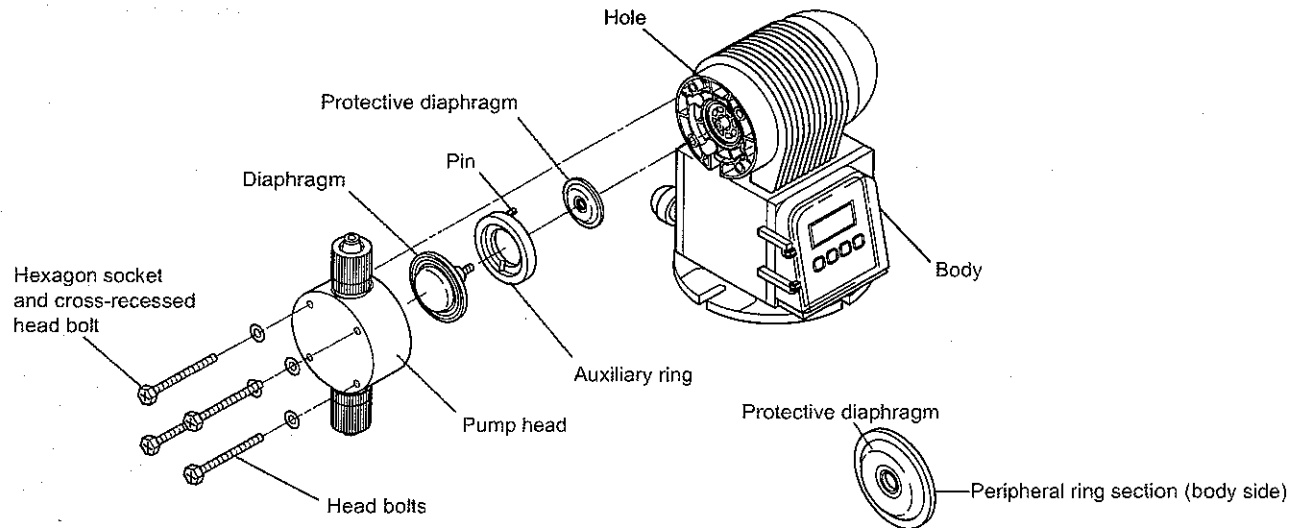

- (3) When the auxiliary ring is removed, the protective diaphragm can be accessed. Grip the spacer to draw out and inspect.

(The protective diaphragm and spacer are combined as shown in the figure.)

IMPORTANT

- Replace the protective diaphragm at the same time that you replace the diaphragm.
- (4) Correctly combine the protective diaphragm with the groove on the spacer, and insert into the pump shaft. (Align the outer peripheral ring on the rear side of the protective diaphragm with the groove on the main unit side.)
 - (5) The fitting position for the auxiliary ring is already determined. When fitting in the auxiliary ring, align the protrusion on the auxiliary ring with the indent on the main unit as shown in the following figures and then fit in. (PZD-31/61/12)

With the PZD-32/52 models, a pin protrudes from the rear side of the auxiliary ring. Align this pin with the hole on the solenoid box.

PZD-31/61/12 model

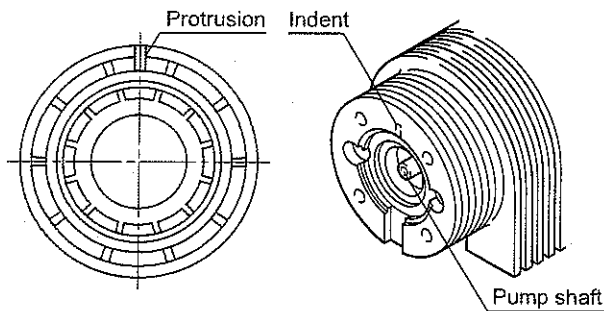

PZD-32/52 model

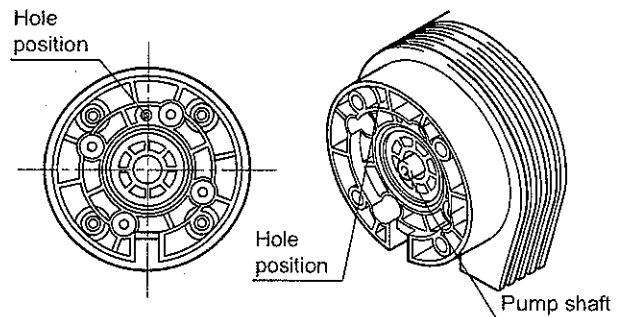

- (6) To attach the diaphragm, firmly turn the diaphragm clockwise until the fitting gets tighter. If the diaphragm fitting is loose, the diaphragm might touch the pump head, resulting in malfunction or damage.
- (7) Fix the pump head in place with the head bolts following the method in 9-3.

10 Troubleshooting

 **WARNING**

- Do not operate the pump with wet hands. Doing so might cause an electric shock.
- Before disassembling the pump, be sure to turn the power OFF, and make sure that voltage is not being applied to the pump. Do not disassemble the pump after just stopping pump operation by the **STOP** key. Also, attach a "Work In Progress" label to the power switch to prevent the pump from being turned ON again during work.
- When performing work on liquid-end parts, be sure to use protective apparatus (rubber gloves, face mask, protective goggles, chemical-resistant work clothes, etc.) matched to the chemicals you are using.
- Before starting maintenance or repair on the pump, be sure to relieve the pressure from the discharge piping, drain chemicals at liquid-end parts, and then clean liquid-end parts.

IMPORTANT

- We recommend using a flow indicator or flow checker as means of detecting defective discharge.

Details of Trouble		Cause	Remedy
Pump operates though chemicals are not transferred.	Air is entering pump.	(1) Gas is occurring due to nature of fluid. (2) Leakage from joints and seals (3) Chemical tank is empty.	(1) Dilute fluid. (2) Tighten a little at a time. (3) Replenish chemicals, and release air.
	Fluid is not rising up.	(1) Foot valve is blocked. (2) Gas lock is occurring on pump. (3) * Pump stroke is too short. (4) Valve is fitted in wrong direction.	(1) Clean foot valve and tank. (2) Release air. (3) * Set stroke to 100%, release air and set stroke. (4) Disassemble and reassemble.
	Pressure does not rise.	(1) Low power voltage or not a commercial power supply	(1) Connect to the correct power supply.
Fluid leakage		(1) Pressure increases due to blockage by debris. (2) Damage caused by hose or diaphragm fatigue (3) Defective tightening of hose nut	(1) Disassemble and clean. (2) Replace with a new part. (3) Tighten.
Pump is not operating.	Pilot lamp does not blink.	(1) Defective power supply and voltage (2) Defective wiring with pump (3) Broken power cable (4) Mains power supply switch is OFF. (5) Breaker is OFF. (6) Internal protective fuse is blown.	(1) Check power supply and voltage, and set to correct voltage. (2) Inspect and correct wiring. (3) Repair or replace. (4) Turn switch ON. (5) Check cause, and restore unit. (6) Ask manufacturer for repair.
	Solenoid does not operate.	(1) Leakage breaker actuated. (2) Defective magnet switch	(1) Ask manufacturer for repair. (2) Replace magnet switch.
Setpoint and discharge volume differ greatly in discharge volume setting mode.		(1) Wrong maximum discharge volume is set. (2) Piping conditions differ from measured values used for setting maximum discharge volume. (3) Stroke differs from that when maximum value was set on 32/52 model.	(1) Set correct maximum value. (2) Measure again under actual conditions, and set maximum discharge volume. (3) Set to required stroke, measure actual discharge volume, and set maximum discharge volume.

* PZD-32/52 models only

11 Warranty

■ Period and Range of Warranty

- (1) The warranty is effective for a period of one full year from the date of delivery.
- (2) If, during the warranty period, the product sustains damage or breakdown despite normal use and proper maintenance as a result of design or manufacturing defect, TACMINA will arrange for repair of the product at no charge to the customer.
However, the customer will be charged for the following expenses:
 1. Replacement of consumables (parts that require regular replacement).
- (3) The customer will be charged for repair of the product or replacement in the event of damage or breakdown in the following cases.
 1. Damage or breakdown occurring or reported after the guarantee period has expired.
 2. Damage or breakdown resulting from careless handling or abnormal operating or maintenance procedures.
 3. Damage or breakdown resulting from the use of parts not made or specified by TACMINA.
 4. Damage or breakdown resulting from repair or remodelling not specified by or using parts not made by TACMINA.
 5. Damage or breakdown resulting from fire, act of God, natural disaster or other unforeseeable circumstances.
 6. Damage or breakdown resulting from the use of materials or parts specified or supplied by the customer.
- (4) In case there is doubt about the cause of the damage or breakdown, the customer and TACMINA will consult on the matter and abide by the result of the consultation.
- (5) Chemical-proof and liquid handling performance of the product with regard to the liquids used by the customer are not covered by this warranty. The liquid-end part materials selected at the time of order are recommended materials and their chemical-proof performance and so on are not covered by warranty.
- (6) TACMINA cannot accept responsibility for any other damage, accident or loss resulting from the breakdown or malfunction of this product.

12 Repair Service

If any abnormality is detected during operation, immediately stop operating the pump and inspect to determine whether it is a malfunction or not.

Before requesting repair, read the operation manual carefully and double-check the possible cause of problems. In the event that the failure needs outside repair work, please contact the store where you purchased the product.

(1) Within the warranty term

Present the warranty document to the store where you purchased the product. The store will arrange the repair according to the warranty contents.

(2) After expiration of the warranty term

Consult the store where you purchased the product. Depending on the type of repair required and whether the pump's functions can be maintained, the store will perform repair according to the customer's request for a charge.



To return the article for repair, be sure to observe the following points in order to maintain the operator's safety and preserve the environment:

- TACMINA regrets that it cannot repair the pump on which the following liquids have been handled.
 - (1) Liquids containing radioactive components
 - (2) Liquids containing bacteria that pose a danger to human health
 - (3) Liquids containing chemical weapon components and other chemical substances which pose a danger to human health
- Wash out the liquid-end part and outside of the pump thoroughly and return it together with the maintenance service datasheet or the safety data sheet (MSDS) for liquids used.
- If the maintenance service data sheet or safety data sheet (MSDS) does not accompany the product, repair work cannot be carried out.
- Even if the maintenance service data sheet or safety data sheet (MSDS) are provided, TACMINA reserves the right to refuse to repair the product if we determine it to be too dangerous.

■ **Minimum Keeping Period for Performance Spare Parts for Repair**

It is TACMINA's policy to keep on hand a stock of spare parts that are vital to the performance and functionality of our products for a minimum of five years after we stop producing a particular model.

13 Contact Us

If you have any questions concerning repair work within the product guarantee period, after-sales service, etc., please feel free to enquire at the store where you purchased the product or to contact your nearest TACMINA sales office.

14 Specifications

14-1 Performance Specifications Tables (PZD series)

Item		Model				
		PZD-31	PZD-61	PZD-12	PZD-32	PZD-52
Max. discharge volume (mL/min)		30	60	100	360	540
Discharge volume per stroke (mL/stroke)		0.1	0.2	0.33	1.2	1.8
Max. discharge pressure (MPa)		1.0		0.7	0.3	0.2
Strokes per minute (spm)		1 to 300				
Stroke length (mm)		1.0			1.5	
Stroke length adjusting range (%)		100% fixed			Adjustable within range 20 to 100%	
Connection aperture	PVC braided hose	Dia. 4 mm x dia. 9 mm	Dia. 6 mm x dia. 11 mm		Dia. 12 mm x dia. 18 mm	
Operating temperature range		Ambient temperature 0 to 40°C				
		Transferring liquid temperature 0 to 40°C				
Transferrable viscosity (mPa·s)		50 or less				
Self suction height (m)		-1.5				
Pump color	Solenoid box	Munsell (approximate) 10YR 7.5/14				
	Circuit box	Munsell (approximate) 5PB 6/2.5				
Weight (kg)		Approx. 1.7	Approx. 1.8		Approx. 4	

* These values are for liquid end material types VEC, VFC and CL. These are different in the case of the FTC/6TC/STC.

* The CL type is not available for the PZD-32/52 models.

14-2 Performance Specifications Table (boiler specification)

Item		Model
		PZD-31
Max. discharge volume (mL/min)		28
Discharge volume per stroke (mL/stroke)		0.093
Max. discharge pressure (MPa)		1.5
Strokes per minute (spm)		1 to 300*
Stroke length (mm)		1.0
Stroke length adjusting range (%)		100% fixed
Connection aperture	Nylon tube (discharge side)	Dia. 4 mm x dia. 6 mm
	PVC braided hose (suction side)	Dia. 4 mm x dia. 9 mm
Operating temperature range		Ambient temperature 0 to 40°C
		Transferring liquid temperature 0 to 40°C
Transferrable viscosity (mPa·s)		50 or less
Self suction height (m)		-1.5
Pump color	Solenoid box	Munsell (approximate) 10YR 7.5/14
	Circuit box	Munsell (approximate) 5PB 6/2.5
Weight (kg)		Approx. 1.8

* The maximum stroke in the boiler specifications (PZD-31 model) is 300 spm. However, operate the pump at 200 spm or less for at least 30 minutes.

14-3 Performance Specifications Table (ARPZD-CL w/ automatic air release)

Item		Model	ARPZD-31	ARPZD-61	ARPZD-12
Max. discharge volume (mL/min)			30	57	93
Max. discharge pressure (MPa)			1.0		0.7
Strokes per minute (spm)			1 to 300		
Stroke length (mm)			1.0		
Stroke length adjusting range (%)			100% fixed		
Connection aperture	PVC braided hose		Dia. 4 mm x dia. 9 mm	Dia. 6 mm x dia. 11 mm	
Operating temperature range			Ambient temperature 0 to 40°C		
			Transferring liquid temperature 0 to 40°C		
Transferrable viscosity (mPa·s)			50 or less		
Self suction height (m)			-1.5		
Pump color	Solenoid box		Munsell (approximate) 10YR 7.5/14		
	Circuit box		Munsell (approximate) 5PB 6/2.5		
Weight (kg)			Approx. 1.7	Approx. 1.8	

14-4 Power Supply Specifications

Item		Model	PZD-31 ARPZD-31	PZD-61 ARPZD-61	PZD-12 ARPZD-12	PZD-32, 52
Power supply (V)	Rating		100 to 240			
	Operating range		90 to 264			
Frequency (Hz)			50/60			
Number of phases (ø)			1			
Peak current (A)			2	2.5	3	
Max. power consumption (VA)			200	250	500	
Average power consumption (W)			15	18	30	

- Use the maximum current when calculating the required power capacity.
- Be sure to use a commercial power supply (power supply provided by power company or equivalent power supply).

■ Unusable Power Supplies

1. Power supply provided with an AC power regulator
2. Power supply on inverter output

15 Liquid-end Materials

• Liquid-end Material Table

Symbol	Pump head	Joint	Diaphragm	Valve seat	Check ball	Hose
VEC	PVC	PVC	PTFE	EPDM	Ceramic	Soft PVC
VFC				Special fluoro-rubber		
CL	Acrylic	—				
FTC	PVDF	PVDF		—		
6TC	SUS316	SUS316		—		PTFE
STC	SUS304	SUS304		—		

Note 1) With the boiler specification, the discharge side hose is nylon tube, and the suction side hose is made of soft PVC. Excluding the hose, specifications are the same as the VEC type.

- 2) Special fluoro rubber, or Vyton by trade name, is a copolymer of vinylidene fluoride and propylene hexafluoride. It is approved by The Food Sanitation Test by Ordinance 434 of the Ministry of Health and Welfare of Japan.

- 3) EPDM is a copolymer of ethylene, propylene, and diene compounds, and is approved by The Food Sanitation Test by Ordinance 434 of the Ministry of Health and Welfare of Japan.
- 4) PVDF (polyvinylidene fluoride) is a di-fluoride resin, and is approved by The Food Sanitation Test by Ordinance 434 of the Ministry of Health and Welfare of Japan.
- 5) PTFE (tetrafluoroethylene resin), or Teflon by trade name, is a type of fluoride resin.
- 6) The FTC, 6TC and STC types are custom order products.
- 7) The CL type is not available for the PZD-32/52 models.
- 8) 6TC is available for the PZD-31/61/12 models, and STC is available only for the PZD-32/52 models.

16 Performance Curves

- (1) Measure the discharge volume by using the calibration function based on actual conditions of use, and set the stroke number according to its performance curve.
- (2) When directly setting the discharge volume, perform calibration, and store the "measured maximum discharge volume value" of the pump to memory before use.

NOTE

- The following performance curves are examples obtained by measuring pump operations under constant conditions on test facilities at TACMINA. These performance curves may differ slightly according to individual site conditions and product differences.

Conditions: Room temperature, clean water, suction height -1 m

PZD-31 model

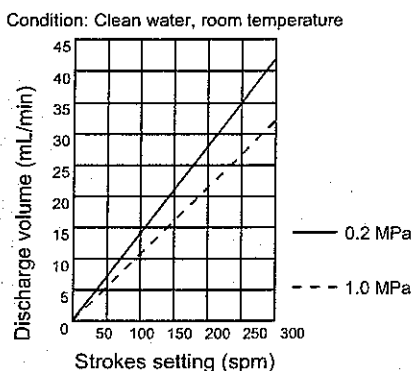

PZD-61 model

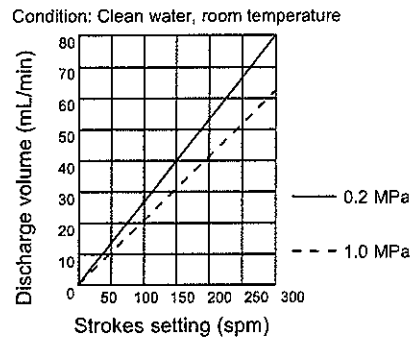

PZD-12 model

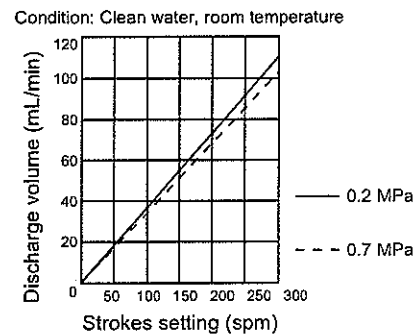

PZD-31 model (Boiler specification)

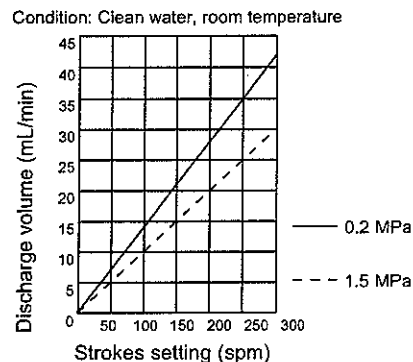

Note: The maximum stroke in the boiler specifications (PZD-31 model) is 300 spm. However, operate the pump at 200 spm or less during continuous operation.

PZD-32 model

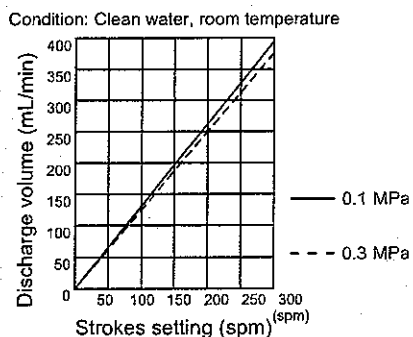

PZD-52 model

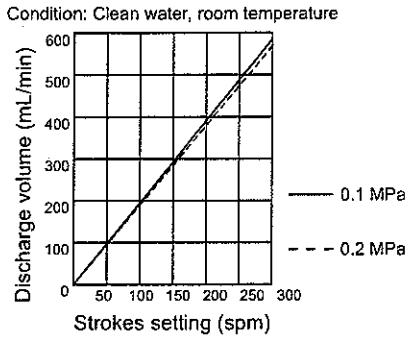

ARPZD-61 model

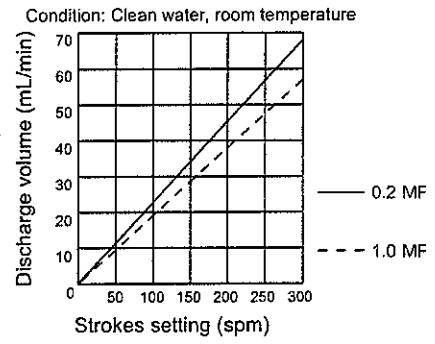

ARPZD-31 model

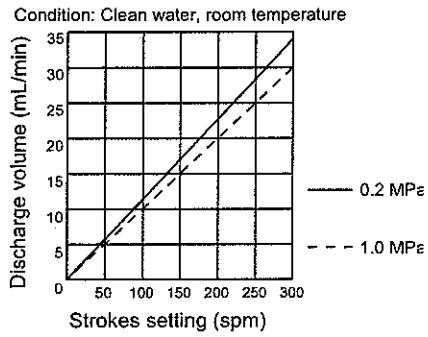

ARPZD-12 model

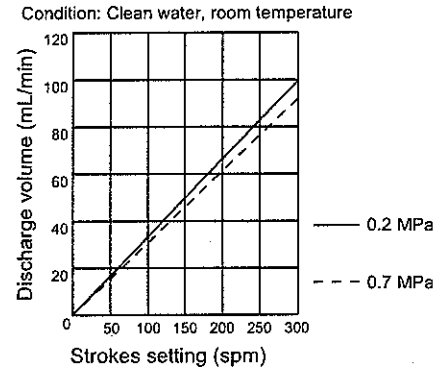

17 External Dimensions

- VEC, VFC type
PZD-31/61/12 model

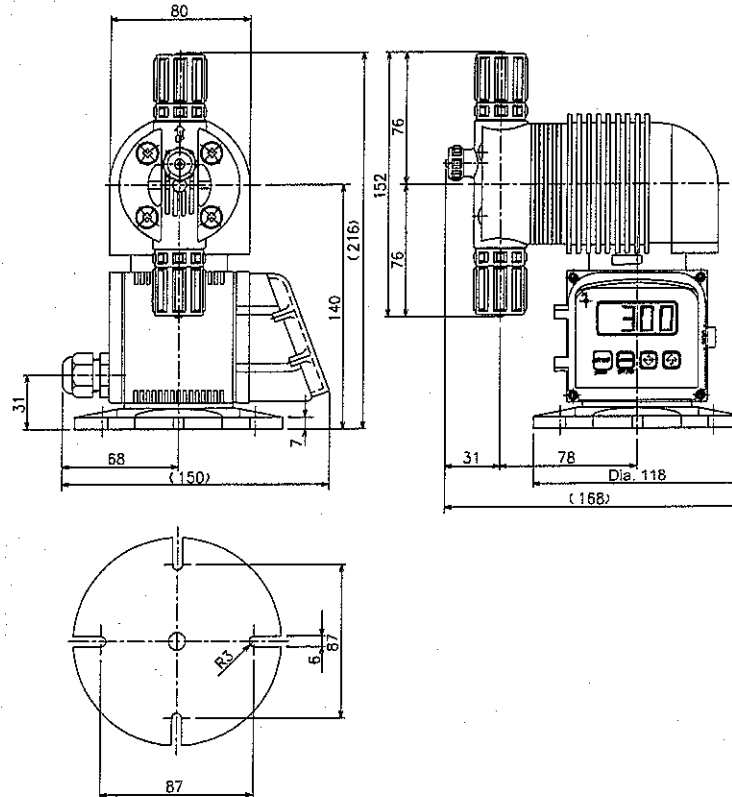

* The shape of parts differ in the case of the FTC and 6TC.

PZD-32/52 model

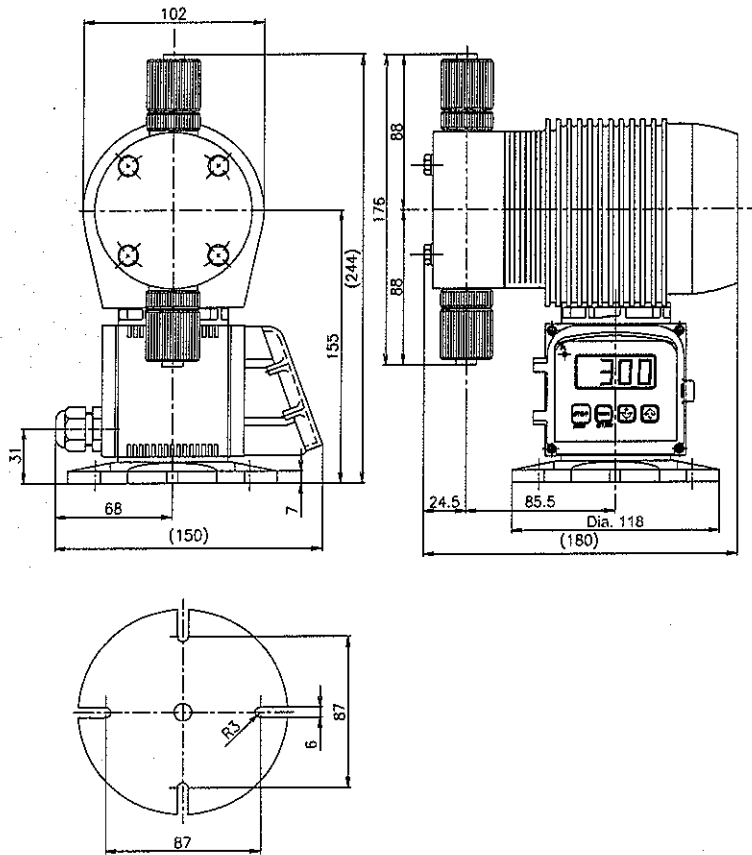

* The shape of parts differ in the case of the FTC and STC.

- CL type
PZD-31/61/12 model

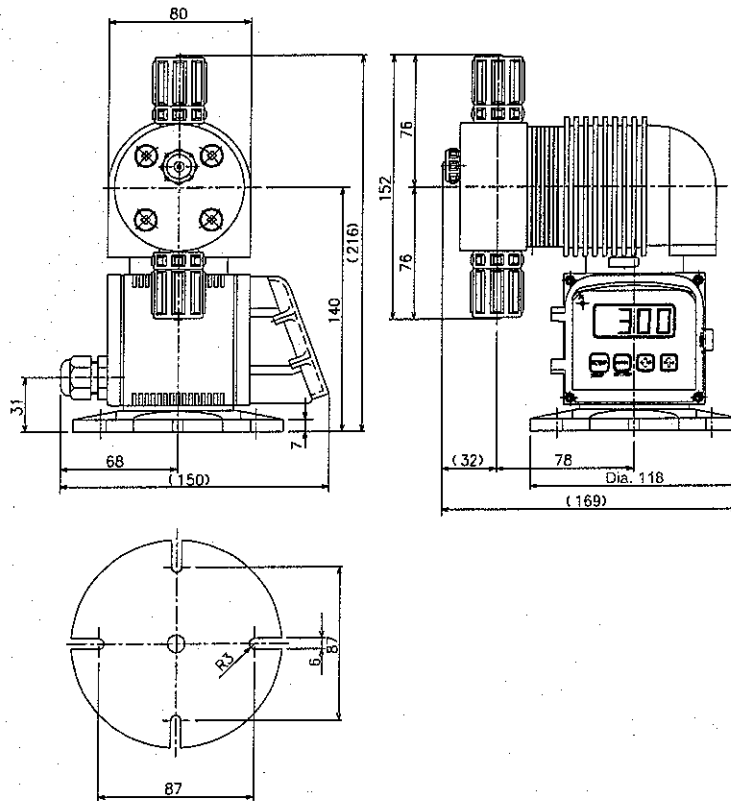

- Boiler specification type
PZD-31 model

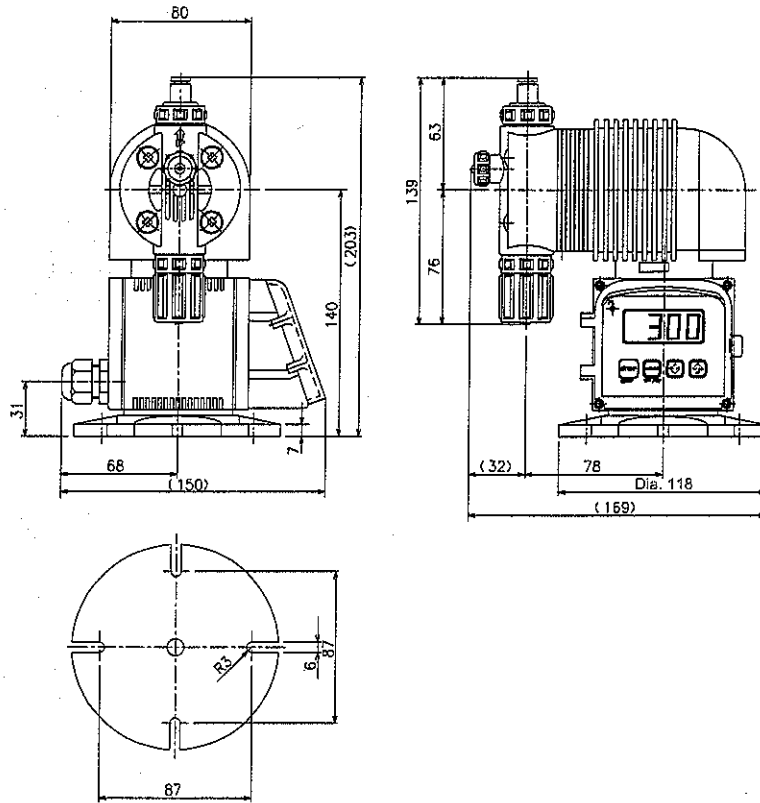

- ARPZD CL type

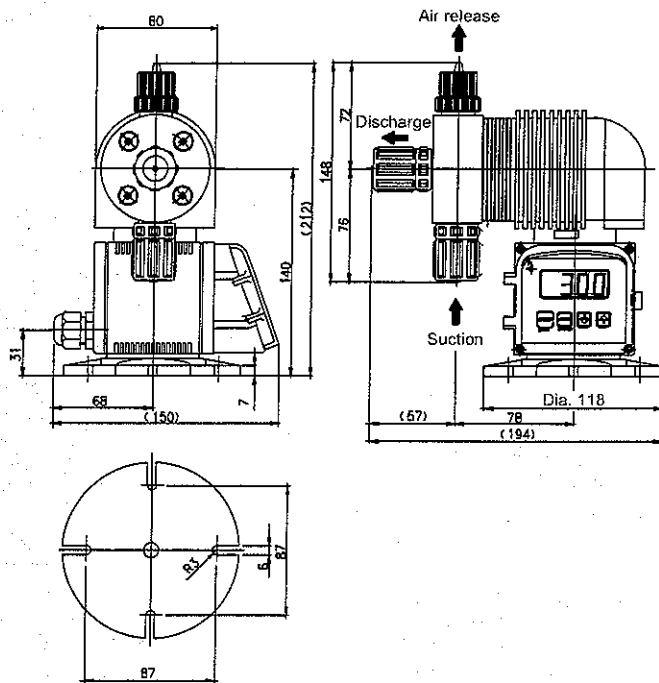

18 Consumables and Spare Parts

18-1 Consumables

- The recommended replacement intervals are for cases where the pump is operated under constant conditions (room temperature and clean water) on test facilities at TACMINA. These cycles change according to individual site conditions. Use these cycles as a rough guideline for replacing consumables. Neglecting to replace consumables may cause defective discharge (injection) or malfunction.
- Neglecting to replace hoses, in particular, will result in chemicals spraying out.

PZD-31/61/12 model

Part Name		Q'ty per unit	Recommended replacement interval
Joint	Valve seat	4	4000 hours or 1 year
	Check ball	4	
	O-ring P12	2	
Diaphragm		1	4000 hours or 1 year
Protective diaphragm		1	
Air release valve (O-ring, duckbill valve, cap integrated product)		1	4000 hours or 1 year
Hose		3 m	4000 hours or 1 year

PZD-32/52 model

Part Name		Q'ty per unit	Recommended replacement interval
Joint	Valve seat	2	4000 hours or 1 year
	Check ball	2	
	O-ring P18	2	
Diaphragm		1	4000 hours or 1 year
Protective diaphragm		1	
Hose		3 m	4000 hours or 1 year

ARPZD-31/61/12 model

Part Name		Q'ty per unit	Recommended replacement interval
Joint	Valve seat	3	4000 hours or 1 year
	Check ball	3	
	O-ring P12	3	
Diaphragm		1	4000 hours or 1 year
Protective diaphragm		1	
Air release set for AR (set includes duckbill valve, check ball, valve seat, and guides)		1	4000 hours or 1 year
Hose		For chemicals 3 m For air release 1 m	4000 hours or 1 year

* The recommended replacement interval is 4,000 hours of operation or one year, whichever is reached the earliest.

NOTE

- Prepare the "Parts Kit" packaged with the Accessory List. (excluding some models)

18-2 Spare Parts

- Hose nut
- Retaining ring
- Hose joint

19 Options and Related Equipment

- Multi-valve (for 31/61/12 models)
This valve is installed directly on the discharge side of the pump to add back pressure, release air, and relieve pressure during maintenance.
- Maintenance valve (boiler specification only)
This valve is installed directly on the discharge side of the pump to release air and relieve pressure during maintenance.
- Back pressure valve
The phenomenon "overfeed" (see description in Glossary) or excessive discharge sometimes occurs depending on the piping conditions. This valve is used to prevent overfeed from occurring.
- Relief valve
This valve automatically relieves pressure when excessive pressure occurs on the pump's discharge piping due to blocking by foreign matter or tightening of valves.
- Air chamber
Reciprocating pumps generate unique pulsation, which sometimes causes vibration on the piping or overfeed. If either of these happen, install the air chamber. This will enable almost continuous flow of chemicals and reduce any problems related to pulsation.
When installing an air chamber, also be sure to install the relief valve described above.
- Accumulator
This option is for reducing pulsation. Its principle of operation is the same as the air chamber. This option is effective when the pressure is 0.98 MPa or higher or when chemicals influenced by air are being used.
- Flow-checker
This checker is installed on the metering pump, and monitors the discharge volume to detect abnormal discharge.
- PTU-25/50/100
This chemical injection unit comprises a metering pump and PE tank (25/50/100L).
- Chemical tank
Made of PE (25 to 100 L) Made of PVC (100 to 1000 L)

- Solution tank
Solution tank that can be mounted on metering pumps and stirrers
(made of PE, 50 to 500 L)
- Parts Kit
Kit including diaphragms, valve seats, and other consumables

20 Glossary

- Overfeed
If the piping on the suction or discharge side of a metering pump is too long, chemicals are discharged at a volume exceeding the rated discharge volume. This is "overfeed."
- Siphoning
If the tip of the pump's discharge piping is located below the level of the fluid in the chemical tank on the suction side, chemicals will continue to flow even after pump operation has stopped. This is "siphoning."
- Cavitation
Back pressure in the pump head causes air bubbles to occur, which reduces the discharge volume and causes abnormal noise or vibration to occur. This is "cavitation."

This is the reference for US users;

14-1 Performance Specifications Tables (PZD series)

Item \ Model	PZD-31	PZD-61	PZD-12	PZD-32	PZD-52
Max. discharge volume G/H (L/H)	0.47 (1.8)	0.95 (3.6)	1.58 (6.0)	5.7 (21.6)	8.5 (32.4)
Discharge volume per stroke (mL/stroke)	0.1	0.2	0.33	1.2	1.8
Max. discharge pressure psi (MPa)	145 (1.0)		101 (0.7)	43.5 (0.3)	29 (0.2)

14-2 Performance Specifications Table (boiler specification)

Item \ Model	PZD-31
Max. discharge volume G/H (L/H)	0.44 (1.68)
Discharge volume per stroke (mL/stroke)	0.093
Max. discharge pressure psi (MPa)	217 (1.5)

14-3 Performance Specifications Table (ARPZD-CL w/ automatic air release)

Item \ Model	ARPZD-31	ARPZD-61	ARPZD-12
Max. discharge volume G/H (L/H)	0.47 (1.8)	0.9 (3.42)	1.47 (5.58)
Max. discharge pressure psi (MPa)	145 (1.0)		101 (0.7)

204 DeKalb Pike
 Lansdale, PA 19446
 Phone: (215) 699-8700
 Fax: (215) 699-0370
 Toll Free Fax: 1-800-255-4017
 E-Mail: pump@neptune1.com
 Web Site : www.neptune1.com



TACMINA CORPORATION

Head Office: 2-4-8 Minami-Semba, Chuo-ku,
 Osaka 542-0081, Japan
 Tel. +81-6-6271-3971 Fax. +81-6-6271-4677
 URL <http://www.tacmina.co.jp>
 E-mail joint@tacmina.co.jp