



# INSTALLATION OPERATION & MAINTENANCE

## NEPTUNE Series 560 “dia-PUMP”



PSG  
22069 Van Buren Street  
Grand Terrace, CA 92313 USA  
P: +1 (215) 699-8700 F: +1 (215) 699-0370  
neptune1.com

Copyright 2018 PSG®, a Dover Company

NEP-ZL105645  
12.2019\_REV 7



# **WARNING**

**LOCKOUTS ARE REQUIRED BEFORE  
SERVICING THIS EQUIPMENT.  
READ INSTRUCTION SERVICE  
MANUALS FOR DETAILS.**

## **SAFETY INSTRUCTIONS:**

**Shut off/Lockout pump Power before Servicing,  
bleed Pressure / Chemical off, etc.**

## WARNING

### Please read thoroughly before installation, operation or maintenance of any Neptune pump

#### **EQUIPMENT MISUSE HAZARD**

Equipment misuse can cause the equipment to rupture, malfunction and result in serious injury.

- This equipment is for professional use only.
- Read all instruction manuals, tags, and labels before operating the equipment.
- Use the equipment only for its intended use.
- Do not alter or modify this equipment.
- Be certain all operators of this equipment have been trained for safe working practices, understand its limitations, and wear safety goggles and or equipment when required.
- Do not exceed the maximum working pressure of the system as mentioned on the pump tag.
- Do not use the pump head or the suction or discharge piping to pull the equipment.
- Do not move pressurized pump.
- Use fluids or cleaning agents for cleaning that are compatible with the pump parts. Read the fluid and cleaning agent manufactures warnings and also refer to the material compatibility chart
- Comply with all applicable local, state and national safety regulations.
- Do not allow pump to run dry.

#### **PRESSURIZED EQUIPMENT HAZARD**

Spray from leaks or ruptured components can splash fluid in the eyes or on the skin and cause serious injury.

- Shut off the pump and depressurize before performing any maintenance.
- Do not tamper with or perform unspecified alteration of this device.
- Use only pipe, hose, and hose fittings rated for maximum rated pressure of the pump or the pressure at which the pressure relief valve is set at.
- Always wear protective clothing, face shield, safety glasses and gloves when working on or near your metering pump.
- Additional precautions should be taken depending on the solution being pumped. Refer to SDS precautions from your solution supplier.
- Do not stop or deflect fluid leaks with your hand, body, glove, or rag.
- Tighten all fluid connections before operating the equipment.
- Replace worn, damaged, or loose parts immediately.
- Before performing any maintenance requiring pump head and or valve (wetted parts) disassembly, be sure to relieve pressure from the piping system and where hazardous process chemicals are present.
- Make the pump safe to handle for the personal and the environment by cleaning and chemically neutralizing the pump as appropriate.
- Wear protective clothing and use proper tools as appropriate to avoid any injury.
- If the diaphragm has failed, process chemical may have contaminated the pump hydraulic oil. Handle with appropriate care. Clean the pump and replace oil as necessary. Discard the contaminated oil as per the local code.
- If the diaphragm fails in a double diaphragm pump, pressurized process chemical can be present in the Neptune leak detection vacuum system. Take proper care to clean and handle them.

#### **FIRE AND EXPLOSION HAZARD**

Improper grounding, poor air ventilation, open flames, or sparks can cause a hazardous condition and result in fire or explosion and serious injury.

- Ground the equipment. See motor installation instruction for grounding procedure.
- Do not pump non recommended flammable or explosive fluids.
- Static electricity may generate by fluid moving through pipes and hoses. A static spark could be produced by high fluid flow rate. Earthing of the pump is a must.
- Provide fresh air ventilation to avoid the possible build up of flammable fumes from the process chemicals.
- Keep the pump area free of debris, including cleaning agent, rags, and any flammable material.
- Follow the cleaning agent and other cleaning recommendations as mentioned in the operation and instruction manuals.
- Use cleaning agent with the highest possible flash point to clean the pump parts if needed.
- If there is any static sparking while using the equipment, stop operation at once. Identify and correct the problem before starting up the pump.

#### **TOXIC FLUID HAZARD**

Hazardous fluids or toxic fumes can cause serious injury or death if splashed in eyes or on the skin, swallowed, or inhaled.

- Know the specific hazards of the fluid you are using. Read the fluid manufactures warnings.
- Store hazardous fluid in an approved container. Dispose of hazardous fluid according to all local, state and national guidelines.
- Wear the appropriate protective clothing, gloves, eyewear and respirator.
- Pipe and dispose of the exhaust air safely. If diaphragm fails, the fluid may be exhausted along with the air in mechanical diaphragm pump. Also oil vapor may breathe out of the air breather installed on the gear box.

#### **SOUND HAZARD**

The sound pressure level of the pump may exceed 80dBA in some of the pumps.

- Observe all safety precautions when operating the pump within close proximity for extended periods by wearing hearing protectors.
- Extended exposure to elevated sound levels will result in permanent loss of hearing acuteness, tinnitus, tiredness, stress, and other effects such as loss of balance and awareness.

#### **MECHANICAL HAZARD**

The pump may shake or vibrate during operation.

## TABLE OF CONTENTS

SECTION	PARAGRAPH		PAGE
I	—	General Description	1
	—	Warranty	2
	—	Parts Ordering Instructions.	3
II	—	Installation instructions	4
	1.0	General	4
	2.0	Suction Piping	6
	3.0	Discharge Piping	6
	4.0	Adjustment of internal Relief Valve	6
	5.0	Installation Outdoors	8
	6.0	Start Up Procedure - Flooded Suction	8
	7.0	Start Up - Suction lift	8
	8.0	Start Up After Suction Has Run Dry	8
III	—	Normal Maintenance	9
	9.0	Maintenance	9
	10.0	Check Valves	10
	11.0	Procedure for Replacing Control Rod O-Ring and Sealing Plate O-Ring	10
	12.0	Procedure for Replacing Diaphragm	10
IV	13.0	Motor Operating Conditions	11
V	—	TroubleShooting Chart.	12
VI		Parts list	14
	14.0	Parts list for Standard Series 560 "dia-PUMP" with Metal Pump Head	14
VII		Drawings	18
		PVC and KYNAR head option	20
APPENDIX		Double Diaphragm Option	21

## SECTION I GENERAL DESCRIPTION

The Neptune Series 560 "dia-PUMP" is a reliable metering pump of the hydraulically actuated diaphragm type. Under constant conditions of temperature, pressure, and capacity adjustment settings, a plus or minus range of 1 % metered discharge volume is maintained.

A plunger reciprocating at a fixed stroke displaces hydraulic fluid, which actuates a flexible, chemically inert, Teflon® diaphragm to create pumping action. The capacity of the pump is regulated by controlling the volume of hydraulic fluid, which bypasses the diaphragm cavity.

Capacity adjustment can be made manually or automatically by instrument signal.

Metering accuracy is maintained by a control rod, which allows hydraulic fluid replacement and air venting automatically with each stroke, while also taking into account temperature changes of the hydraulic fluid. Metering accuracy is also insured by the use of double ball check valves on the suction and discharge ends of the pump.

**PLEASE READ THE INSTRUCTION MANUAL COMPLETELY BEFORE INSTALLING THE PUMP.**



**SERIES 560 "dia-PUMP"  
PVC (N5) HEAD WITH  
INTEGRAL TEFC MOTOR**

## LIMITED WARRANTY

All Neptune Pumps are tested at the factory prior to shipment. Each part used in their construction has been carefully checked for workmanship.

If the pump is installed properly, Neptune Chemical Pump Company warrants to the purchaser of this product for a period of thirty six months from the date of first use or eighteen months from shipment, whichever occurs first, this product shall be free of defects in material and/or workmanship, as follows:

1. Neptune Chemical Pump Company will replace, at no charge, any part that fails due to a defect in material and/or workmanship during the warranty period, FOB our factory, North Wales, Pennsylvania. To obtain warranty service, you must get an RMA number to return the defective parts to the factory for examination, freight pre-paid.
2. This warranty period does not cover any product or product part, which has been subject to accident, misuse, abuse or negligence. Neptune Chemical Pump Company shall only be liable under this warranty if the product is used in the manner intended by the manufacturer as specified in the written instructions furnished with this product.

Any express warranty not provided in this warranty document, and any remedy for breach of contract that, but for this provision, might arise by implication or operation of law, is hereby excluded and disclaimed. Under no circumstances shall Neptune Chemical Pump Company be liable to purchaser or any other person for any charge for labor, repairs, or parts, performed or furnished by others, nor for any incidental consequential damages, whether arising out of breach of warranty, express or implied, a breach of contract or otherwise. Except to the extent prohibited by applicable law, any implied warranty of merchantability and fitness for a particular purpose are expressly limited in duration to the duration of this limited warranty.

Some states do not allow the exclusion or limitation of incidental or consequential damages, or allow limitations on how long any implied warranty lasts, so the above limitations may not apply to you. This warranty gives you specific legal rights, and you may have other rights, which may vary from state to state.

## IMPORTANT

SHOULD IT BE NECESSARY TO SEND THE PUMP TO THE FACTORY FOR REPAIR OR MAINTENANCE REBUILDING; DRAIN ALL OIL AND CHEMICAL FROM PUMP BEFORE SHIPPING. FAILURE TO DO SO CAN CAUSE EXTENSIVE DAMAGE TO THE MOTOR.

<sup>1</sup>SEE IMPORTANT NOTICE -RETURN GOODS AUTHORIZATION

### **IMPORTANT NOTICE RETURN GOODS AUTHORIZATION**

- (1) All equipment returned to Neptune Chemical Pump Company requires proper Returned Goods Authorization Number (RGA) and tags.
- (2) All equipment returned to the factory for repair or service must first be thoroughly flushed and have all chemical contact areas neutralized.
- (3) All equipment which has been in contact with chemicals must be accompanied by a copy of the chemical product material Safety Data Sheet (SDS).
- (4) Failure to comply with the above instructions will result in equipment being returned to sender, freight collect, without service.

## PARTS ORDERING INSTRUCTIONS

The complete model number and serial number of the pump must be furnished to insure prompt and accurate parts service. These numbers are found on the name plate (sample below) located on the side of the pump. Refer to Section VII for complete parts lists.

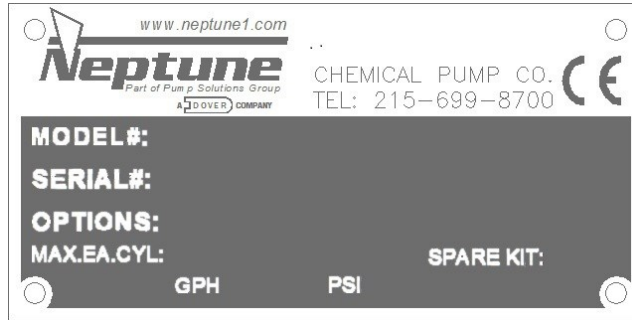

**Send all orders or inquiries for parts to:**

Email: [orders.neptune@psgdover.com](mailto:orders.neptune@psgdover.com)

Website: [www.psgdover.com/neptune](http://www.psgdover.com/neptune)

## SECTION II

### INSTALLATION INSTRUCTIONS

#### 1.0 GENERAL

- 1.0.1 When unpacking a pump or chemical feed system, be certain that no parts are thrown away. Examine the equipment for possible damage. If damage has occurred, file claim with the common carrier within 24 hours. Neptune will assist in estimating the repair costs.
- 1.0.2 The “dia-PUMP” should be located so as to avoid an ambient temperature above 120°F, 50°C. Free air circulation is important when considering the location of the pump.
- 1.0.3 The “dia-PUMP” should be located on a level surface. Three mounting holes are provided to anchor the pump securely to the mounting surface. PVC head pumps must be mounted on riser, which needs to be secured on the surface.
- 1.0.4 Neptune recommends a 4” to 6” inch clearance above mounting surface to allow access to the Valve Stack. Please refer to model and valve location prior to installation.
- 1.0.5 All piping to the pump should be supported to prevent stress on the pump input and output fittings.
- 1.0.6 Before connecting the pump, make sure that all fittings are completely clean by flushing thoroughly. Any foreign matter entering the pump can damage the internal parts and severely limit the life of the pump.
- 1.0.7 A “Y” STRAINER MUST BE INSTALLED IN THE SUCTION LINE OF THE PUMP TO INSURE AGAINST FOREIGN MATTER ENTERING THE PUMP. ALL SUCTION LIFT APPLICATIONS REQUIRE A FOOT VALVE STRAINER TO PREVENT LOSS OF PRIME, AND TO PREVENT FOREIGN MATERIAL FROM ENTERING THE PUMP.
- 1.0.8 Shut-off valves and unions should be placed in the suction and discharge lines to facilitate servicing the pump.
- 1.0.9 Care should be exercised when piping to PVC head pumps. In cases where vibration or stress is unavoidable, flexible connections should be used.
- 1.0.10 The electrical supply to the pump must match the motor name plate characteristics. The motor rotation is counter clockwise when viewed from the top of the motor, looking down on the pump. (See Figure 1 on page #5).
- 1.0.11 Discharge Piping should be the same size or larger than the discharge connection. Suction Piping should be one size larger than the suction connection. Limit the total length of the suction line to 3-4 feet suction lift or 6-7 feet flooded suction. Minimum bends, elbows, or other restrictions.

#### **Important**

On single phase integral motors, the rotation is set at the factory and must not be changed.

On three phase integral motors, rotation is determined by noting the fan rotation.

Pump body is grounded to earth. Ground connection MUST penetrate to bare metal. Ground to be clearly marked.

Check external pressure relief valve setting.

On some flange mounted motors, the motor rotation may be viewed by removing the cap plug on the side of the flange. There is no viewing port or coupling access on the close-coupled flange mount motors. Rotation is checked by removing the oil fill plug and observing the gear. Correct rotation is indicated by the gear teeth moving downward away from the oil fill hole.

Please note Figure 1 on page #5 indicating the correct rotation. (An arrow on the gear box also indicates proper rotation). Operation with the incorrect rotation will damage the pump and motor.



1.0.9 (Continued)

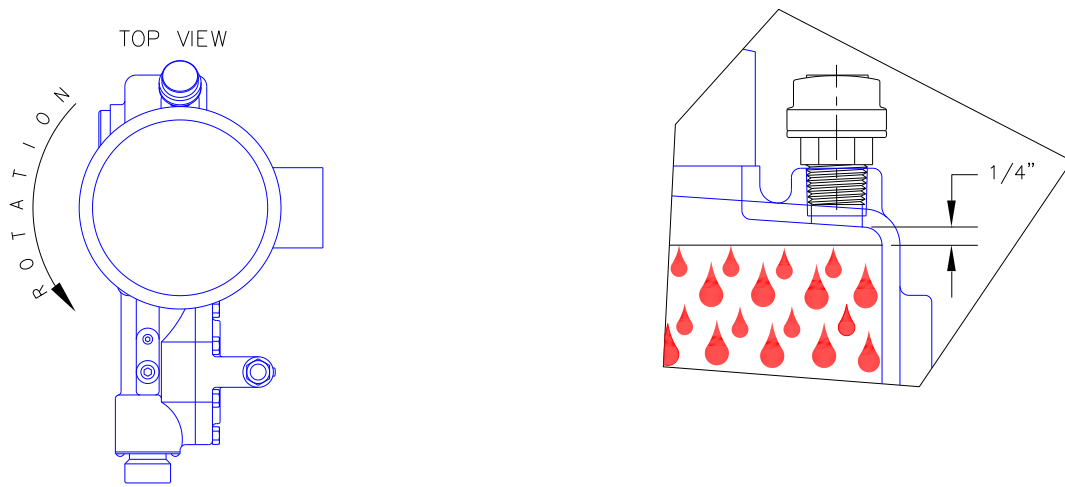

**FIGURE 1**

1.0.11 Set capacity knob to zero and remove Air Bleed Plug from the top of Oil Chamber, refer to drawings 5670 (Page 19) for the location of plug (#512). Fill gear box and pump by pouring the hydraulic fluid supplied through the fill opening at the rear of the pump. Pour fluid in slowly until it has reached the correct level per figure above. Do not over fill as this can cause damage to the motor.

Allow a few minutes for the hydraulic fluid make its way into the pump chamber and then recheck fluid Level, reinstall Air Bleed Plug.

**The hydraulic fluid supplied by Neptune is:**

EP Gear Oil, ISO #68, consult the parts listing in the back of this manual for the Neptune part number.

Heavier hydraulic fluid is supplied by Neptune for Hi Pressure Systems is EP SAE 90.

<b>Alternate Oils For Standard</b>	<b>Mfg.</b>	<b>Alternate High Pressure Oils</b>
Mobil Gear #626	Mobil Oil	Mobil Gear #629
Sun EP #68	Sun Oil	Sun Oil #220
Meropa #68	Texaco	Meropa #220

1.0.12 Please note that this manual describes both metal head pumps (Material Code N1, N3 or N4) and PVC head pump (Material Code N5) or KYNAR head (Material Code N8). The figure number references used throughout the manual are for the metal head pumps. The metal pumps are shown on drawing 5670 on page #18. The comparable PVC and KYNAR head pump parts are shown on the New Style PVC and KYNAR Head drawing on page #20.

## 2.0 SUCTION PIPING

- 2.0.1 The suction piping to the pump must be absolutely air tight. It is suggested that the suction piping be tested with low air pressure and a soap solution to assure that no leaks exist.
- 2.0.2 Neptune recommends that the "dia-PUMP" be operated with a flooded suction, as this will facilitate start up and increase the service life of the pump. It is, however, possible to operate the "dia-PUMP" with a suction lift of up to 5 feet, if absolutely necessary. A foot valve strainer must be used on this type of application.
- 2.0.3 It is highly recommended that all solution tanks be purchased with a low level cut off switch or low level alarm and cut off switch to prevent the pump from running dry. OPERATION AGAINST A DRY SYSTEM WILL CAUSE DAMAGE TO THE PUMP DIAPHRAGM AND REDUCE THE OPERATING LIFE OF THE PUMP.

## 3.0 DISCHARGE PIPING

- 3.0.1 It is recommended that the "dia-PUMP" operate against a minimum discharge pressure of 50 psig. An anti-siphon spring is supplied loose with the pump. If 50 psig back pressure is not provided by the application, the anti-siphon spring (FIG. #5666\*) should be installed on the pin under the vent plug (FIG. #5604\*). Installation of the anti-siphon spring artificially creates a discharge head.

An external Back Pressure valve should be used with PVC or KYNAR head pumps.

\*Refer to part list on page #14

## 4.0 ADJUSTMENT OF INTERNAL RELIEF VALVE

- 4.0.1 All Neptune Series 560 dia-PUMPs are supplied with an internally pre-set relief valve. THIS RELIEF VALVE IS SET AT 175 PSI AND IS DESIGNED TO PROTECT THE PUMP SHOULD A DISCHARGE PRESSURE BEYOND THE RATED LIMIT OF THE PUMP OCCUR. If a customer order specifies a relief valve setting above those indicated above, the specified setting will be set at the factory. All pumps are tagged with the relief valve setting used by the factory.

To protect the external piping system, it is recommended that a relief valve as manufactured by Neptune Chemical Pump Company, or equal, be placed in the discharge line of the pump. It is further recommended that this relief valve be piped into return of the tank with clear PVC tubing so that it can be determined if the solution is by-passing through the valve and returning to the tank, indicating a line blockage.

Drawing 5670 on page#18, illustrates the location of the Internal Relief Valve (FIG. #5648 through #5652).

The drawing shows a passage connecting the hydraulic fluid reservoir with the hydraulic fluid side of the diaphragm.

The passage is interrupted by the Relief Valve Ball (FIG. #5648) which is backed up by a Relief Valve Spring (FIG. #5650).

If, during the pump operation, the pressure on the hydraulic fluid side of the pump exceeds the set pressure of the internal relief valve, the ball is forced from its seat allowing the hydraulic fluid to flow back to the reservoir.

4.0.2 To reset the relief valve to a higher pressure, instructions are as follows:

4.0.21 Connect a test set-up as shown in Figure IV below.

4.0.22 Start and run the pump until all air is relieved from the discharge liquid (hand valve open).

4.0.23 Remove Relief Valve Plug (Fig. #5651).

4.0.24 Close hand valve; pressure gauge should read 175 psi, depending on pump model.

4.0.25 Use the 1/4" Allen Wrench to adjust spring tension by turning Relief Valve Adjusting Screw (FIG. #5652).

(1) To increase pressure, turn Relief Valve Adjusting Screw (Fig. #5652) in.

(2) To decrease pressure, turn Relief Valve Adjusting Screw (Fig.#5652) out.

4.0.26 After resetting or adjusting pressure, replace Relief Valve Plug (Fig. #5651).

### CAUTION

Never turn Relief Valve Adjusting Screw (Fig. #5652) completely in.

Do not attempt to set the internal relief valve more than 200 psi in excess of name plate rating.

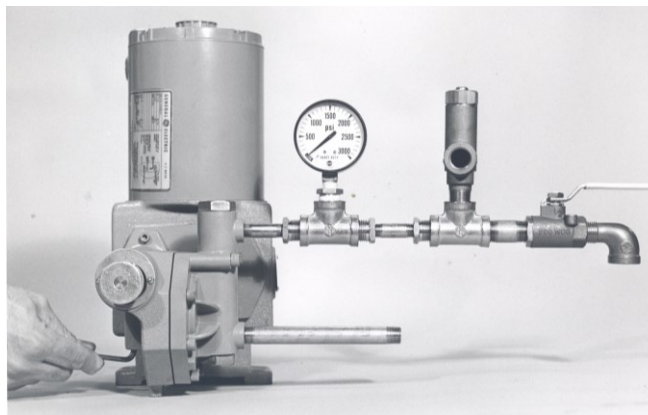

FIGURE IV

4.0.3 Parts required to test or adjust Relief Valve Pressure.

- 1 Pc. 1/2" x1/4" reducer bushing
- 1 Pc. 1/2" street elbow
- 3 Pcs. 1/2" pipe nipple 2" long
- 1 Pc. 1/2" hand valve
- 2 Pcs. 1/2" tee
- 1 Pc. 3/4" MNPT X 5/8" hose (fitting)
- 1 Pc. 5/8" hose, as required
- 1 Pc. 1/4" pressure gauge (minimum gauge pressure 500 psi)
- 1 Pc. Allen wrench 1/4"
- 1 Pc. External relief valve (optional)

### NOTE

The above parts must have a working pressure rating above the required set pressure.

## 5.0 INSTALLATION OUTDOORS

The “dia-pump” is a totally enclosed pump which can be used outdoors or indoors. When installed outdoors, make sure that the pump is protected against extremes of nature as follows:

- 5.0.1. Running of the pump when exposed to tropical sunshine, with ambient temperature above 90°F (32°C) would cause excessive oil and motor temperatures. The pump should be shaded and located in such a way as to permit ample air circulation.
- 5.0.2 Under cold conditions, the pump should be insulated and a heater should be supplied in order to maintain the hydraulic fluid at an ambient temperature above 30°F (-1°C).

## 6.0 START-UP PROCEDURE-FLOODED SUCTION

The following start-up procedure is complete and does repeat instructions on filling the gear box and pump.

- 6.0.1 Flooded Suction: Refer to Section II, Paragraph 1.0.11. for instructions on filling gear box with hydraulic fluid.

**NOTE:** Refer to Paragraph 12.3 (page#11) for special start-up instructions after replacing diaphragm.

- 6.0.2 After having let pump stand for 30 minutes and having rechecked fluid level, set pump capacity indicator at approximately 30%. Be certain that pump suction and discharge lines are open.
- 6.0.3 Make certain that pumping chamber is flooded by loosening Vent Plug (FIG.#5604) and allowing solution to appear. Then tighten discharge vent plug. This procedure will also allow air to vent from pumping chamber. **THE “dia-PUMP” WILL NOT FUNCTION IF AIR IS TRAPPED IN THE HYDRAULIC FLUID OR LIQUID PUMP CHAMBERS.** Start Pump.
- 6.0.4 The pump is now ready for “on line” service.
- 6.0.5 You may calculate what the desired capacity is, as a percentage of either the maximum capacity rating on the pump data plate, or the nominal capacity at the required system pressure.

## 7.0 START-UP PROCEDURE SUCTION LIFT

- 7.0.1 If the “dia-PUMP” is to be used where suction lift is required, A FOOT VALVE STRAINER MUST BE INSTALLED on the end of the suction line. A pipe tee is installed on the top end of the suction line with one leg to the pump suction, one leg to the suction line and one leg pointing straight up and valved. Open valve and force prime pump and piping with water. Start pump.

**WARNING:** Beware of application where water is not compatible with chemical to be pumped.  
Example: Never force prime when pumping acid or oil based products.

## 8.0 START-UP AFTER SUCTION HAS RUN DRY

In applications where the suction tank does not have a low level cutoff interconnected into the pump motor circuit, the pump may occasionally run dry. **THIS MUST BE AVOIDED BECAUSE DAMAGE TO THE PUMP CAN RESULT AND THE SERVICE LIFE WILL BE SIGNIFICANTLY REDUCED WHEN THE PUMP IS ALLOWED TO RUN WITH A DRY LIQUID END.**

Before restarting a pump that has run dry and which has not been damaged by running dry, follow the procedure in Paragraph 6.0 through 6.0.3 of Section II

## SECTION III

### NORMAL MAINTENANCE

#### 9.0 MAINTENANCE

Under normal conditions, the “dia-PUMP” does not require any significant amount of maintenance. It is advised that periodic visual observations be made of the oil level to make sure that it is within limit (see fig 1, page#5). The liquid end of the pump should also be inspected for leakage. These observations should be made regularly, at least every 48 hours.

The hydraulic fluid should be drained and replaced TWICE a year, using the drain plug (FIG #510, page#18) on the side of the pump. This change can be scheduled with the normal factory maintenance at seasonal periods.

<b>Recommended Maintenance Schedule</b>
<b>Weekly Interval</b>
<ul style="list-style-type: none"><li>• Check oil level</li></ul>
<ul style="list-style-type: none"><li>• Check for leaks</li></ul>
<ul style="list-style-type: none"><li>• Check ground connection for corrosion</li></ul>
<ul style="list-style-type: none"><li>• Clean pump surfaces and surrounding area of dust and debris</li></ul>
<b>First 250 hours of operation</b>
<ul style="list-style-type: none"><li>• Change oil</li></ul>
<b>Every 4000 hours or six months</b>
<ul style="list-style-type: none"><li>• Change oil</li></ul>
<ul style="list-style-type: none"><li>• Clean inlet piping strainer &amp; check external pressure relief valve</li></ul>
<ul style="list-style-type: none"><li>• Replace worm shaft oil seal</li></ul>
<ul style="list-style-type: none"><li>• If equipped, check coupling insert. Replace if necessary.</li></ul>
<ul style="list-style-type: none"><li>• Tighten all fasteners</li></ul>
<b>Annual</b>
<ul style="list-style-type: none"><li>• Clean check valves. Replace O-rings.</li></ul>
<ul style="list-style-type: none"><li>• Replace diaphragm</li></ul>
<ul style="list-style-type: none"><li>• If equipped, replace coupling insert.</li></ul>
<ul style="list-style-type: none"><li>• Replace rolling element bearings</li></ul>
<ul style="list-style-type: none"><li>• Replace O-rings</li></ul>
<ul style="list-style-type: none"><li>• Replace check valves</li></ul>

## 10.0 CHECK VALVES: REMOVING, CLEANING, AND REPLACING

The "dia-PUMP" incorporates a unique check valve design whereas the discharge and suction piping NEED NOT be disturbed in order to service the valves. Should the valves need cleaning, remove as follows:

NOTE: For PVC or KYNAR heads, the connection piping have to be removed.

**CAUTION:** Do not over tighten PVC Suction and discharge valves, as the PVC material is not able to withstand excessive force and can fail. Teflon paste is an excellent thread lubricant and may be applied.

### 11.0.0 PROCEDURE FOR REPLACING CONTROL ROD "O" RING (fig. #2334) AND SEALING PLATE "O" RING (FIG. #516-C on Page#18).

11.0.1 Remove hydraulic fluid from gearbox.

11.0.2 Remove indicator plate (FIG. #520) by removing two indicator plate screws (FIG. #521).

11.0.3 Remove control rod assembly with control rod attached (FIG. #524, #523, and #5615) by turning counter clockwise until threads are disengaged, then pull out.

**NOTE: Some pump models may have O-ring on sealing nut, refer to FIG. #5699 if O-ring is needed or requires replacement.**

11.0.4 Use an 11/16" Hex socket on the sealing nut (FIG. #526) and screw out of pump in a counter clockwise direction. Then, remove sealing plate (FIG. #5602) using a small brass hook to pull loose.

11.0.5 Replace control rod O-ring (FIG. #2334) and/or sealing plate O-ring (FIG. #516-C).

11.0.6 When replacing sealing plate, be careful not to shear the sealing plate O-ring (FIG. #516-C).

11.0.7 Replace balance of parts and fill pump with hydraulic fluid per previous instructions.

11.0.8 Follow start-up procedure as if starting a new pump.

### 12.0.0 Procedure for replacing Diaphragm on Pumps with metal head models.

12.0.1 Removal of pump head and replacement of diaphragm.

12.0.2 Remove drain plug (FIG. #510), and drain hydraulic fluid.

12.0.3 Remove long and short pump head bolts (FIG. #551). Lift pump head (FIG.#5660) away from pump.

12.0.4 Remove and examine Teflon diaphragm (FIG. #2310). Remove and examine the liquid side diaphragm backup plate (FIG. #2330).

12.0.5 Replace with new part, if required. When replacing the Teflon diaphragm, be certain to line it up properly with the sealing grooves.

12.0.6 To reassemble, reverse the above procedure. Reassembly is facilitated by laying the pump on its side. Be certain to tighten all the bolts evenly. Tighten to 25 ft. lbs.

### 12.1.0 Removal of pump head and replacement of diaphragm on PVC head model. (Refer to Drawing on Page#20).

12.1.1 Loosen (8) bolts (FIG#3). Lift pump head (FIG. #1) away from pump.

12.1.2 Remove and examine Teflon diaphragm (FIG. #5).

12.1.3 Replace with new Teflon diaphragm, if required. When replacing the Teflon diaphragm, be certain to line it up properly with the sealing grooves.

12.1.4 To reassemble, reverse the above procedure. Reassembly is facilitated by laying the pump on its side. Be certain to tighten all bolts evenly. Tighten to 10 ft. lbs.

### **12.3.0 Start-up instructions after replacing diaphragm.**

- 12.3.1 Fill gearbox with oil (leaving 1/4" - 1/2" inches of air space). Using warm oil is best.
- 12.3.2 Refer steps at 6.0 (START UP PROCEDURE- FLOODED SUCTION) ON PAGE #8.
- 12.3.3 Remove anti-siphon spring under discharge cap (to be replaced after pump start up if needed).
- 12.3.4 Run pump at 0% to allow pump to warm up. (Start pumping on test bench or testing area.)  
(Liquid supply is required-water is recommended.)
- 12.3.5 Start up at a low percentage Try 20% for about 15 minutes then increase to 40% for 15 minutes and repeat for 60%-80%-100%.
- 12.3.6 Recheck for proper sealing and test for required pump capacity.
- 12.3.7 Pump is now ready for hook-up to system.

## **SECTION IV MOTOR OPERATING CONDITIONS**

- 13.0 The standard Series 560 "dia-PUMP" is supplied with 1/3 HP, single phase, capacitor start, totally enclosed fan-cooled motor as an integral part of the pump itself.

The normal temperature rise for this motor is 40°C above ambient temperature and, thus, it might appear that the motor is operating at a higher than normal temperature. This situation is normal and should not cause concern.

As a precaution against motor overheating, it is recommended that the pump be located where adequate ventilation is available. It is also highly RECOMMENDED THAT A MOTOR STARTER WITH THE PROPER OVERLOAD PROTECTION BE SUPPLIED AS AN ADDITIONAL SAFETY DEVICE.

## SECTION V

### TROUBLESHOOTING CHART

Symptom	Cause	Remedy
1. Pump Motor Will Not Operate.	A. Blown Fuse.	Check for short circuit or overload.
	B. Low liquid level in tank (where low level cut-off is used).	Fill tank.
	C. Broken wire.	Locate and repair.
	D. Low voltage.	Check for too light wiring.
	E. Oil "frozen" in pump.	Thaw out.
*2. Pump Does Not Deliver Rated Capacity	A. Starved suction.	Replace suction piping with larger size, or increase suction head.
	B. Leaky suction piping.	Pressure test, repair or replace defective piping.
	C. Excessive suction lift.	Rearrange equipment location to reduce suction lift.
	D. Liquid too close to boiling point.	Lower temperature or increase suction head pressure slightly.
	E. Air or gas trapped in oil or chemical solution.	Decrease capacity to 20% for 7 minutes, then increase to 100% for 7 minutes.
	F. Worn or dirty valves or seats, or both.	Clean or replace.
	G. Viscosity of liquid too high.	(1) Reduce viscosity by heating or other means.
		(2) Increase size of suction piping.
		(3) Increase suction pressure slightly
	H. Insoluble materials, crystallization or solids settling.	Limit solution strength to 5% by weight. Flush and clean solution tank periodically. Suction connection should be 2" - 4" from bottom of solution tank.
I. Low discharge pressure.	A minimum discharge pressure of 50 psi is required to insure proper capacity control.	
J. Air in hydraulic or chemical systems.	Bleed system.	



Symptom	Cause	Remedy
*3. Pump delivers erratically.	A. Leaky suction line.	Repair or replace piping.
	B. Worn or dirty valves seats, or both.	Clean or replace suction & discharge Valve assemblies.
	C. Excessive excursion of ball from valve seats (indicated by ball chatter).	Increase back pressure (install anti-siphon spring).
	D. Insufficient suction pressure.	Increase suction pressure. Raise tank level.
	E. Liquid too close to boiling point.	Reduce temperature or raise suction pressure.
	F. Leaky system relief valve.	Repair or replace relief valve.
	G. Low hydraulic fluid	Add hydraulic fluid.
4. Motor Overheats.	A. Power supply does not match motor.	Check power supply against motor nameplate data.
	B. Overload caused by operating pump beyond rated capacity.	Check operating pressure against pump manufacturer's data plate maximum rating.
5. Noisy Operation (1) In Pump	A. Pump Valves.	Valves must move to open and close, and they will make a clicking noise as they operate. These noises are sometimes amplified by natural resonances in piping system. They are usually indications of normal valve functioning.
	(2) In Gear Reducer	A. Pounding noise at high discharge pressure.
6. Oil level overflows Reservoir.	A. Flexible diaphragm punctured.	Replace diaphragm and hydraulic fluid (drive lubricant) if contaminated.

**\*Note:** A diaphragm change may be needed for symptoms #2 & #3

SECTION VI

PARTS LIST

14.0 PARTS LIST FOR STANDARD SERIES 560 "DIA-PUMP" WITH METAL PUMP HEAD (REFER TO DRAWING #5670)

FIG. NO.	DESCRIPTION	QTY.	PART NO.
501	Worm Gear 37 SPM*	1	000164
	Worm Gear 72 SPM*	1	000166
	Worm Gear 117 SPM*	1	000163
	Worm Gear 144 SPM*	1	002818
502	Connecting Rod	1	000167
506	Worm 37 SPM	1	000170
	Worm 72 SPM	1	000172
	Worm 117 SPM	1	000169
	Worm 144 SPM	1	002817
507	Bearing Cup	1	100179
508	Bearing Cone	1	100180
509	Worm Spring Pin	1	100181
510	Drain Plug	1	100182
511	Connecting Rod Pin	1	100183
512	Fill Plug	1	000191
516-C	Sealing Plate O-Ring	1	100186
519	Control Rod Spring Pin	1	100189
520	Indicator Plate	1	000188
521	Indicator Plate Screws	2	100190
522	Control Knob Set Screw	1	100191
523	Control Rod Positioner	1	000189
524	Control Knob Assembly	1	002071
525	Capacity Indicator Scale	1	100192
526	Sealing Nut	1	002069
530	Pipe Plug	1	100196
534	Pump Body Cap Screws	4	100293
551	Screw 5/16 x 1 1/4" lg. (N1)	8	100205
	Screw 5/16 x 1" lg. (N3, N4)	8	100206
557	Hydraulic Fluid (2 qts.) ISO68	1	003089
590	Gasket or Sealer	1	106290
2309	Pump Body Side Backup Plate	1	000387
2310	Teflon Diaphragm	1	000388
2330	Pump Head Back Up Plate (N1, N3)	1	000406
	Pump Head Back Up Plate (N4)	1	000407
2334	Control Rod O-Ring	1	100323
2337	Vent Plug O-Ring	1	100325
2340	Valve Balls (N1, N3)	4	100078
	Valve Balls (N4)	4	100079
2342	Valve Seat O-Ring	4	100327

FIG. NO.	DESCRIPTION	QTY.	PART NO.
2343	Discharge & Suction Cap O-Rings	2	100328
5002	Shaft Retainer Assembly*	1	002722
5004	Thrust Washers	3-4	100252
5025	Shaft Retainer Screws	3	100254
5601	Gear Box	1	000296
5602	Sealing Plate	1	000307
5604	Vent Plug (N1, N3)	1	000308
	Vent Plug (N4)	1	000309
5606	Suction Spacer (N1, N3)	1	000310
	Suction Spacer (N4)	1	000311
5608	Discharge Spacer (N1, N3)	1	000312
	Discharge Spacer (N4)	1	000313
5610	Discharge Cap (N1, N3)	1	000303
	Discharge Cap (N4)	1	000304
5612	Suction Cap (N1, N3)	1	000301
	Suction Cap (N4)	1	000302
5614	Piston 2"	1	000314
5615	Control Rod	1	000315
5648	Relief Valve Ball	1	100201
5650	Relief Valve Spring 1/3 & 1/2 HP	1	100276
	Relief Valve Spring 3/4 & 1 HP	1	106428
5651	Relief Valve Plug	1	108044
5652	Relief Valve Adjusting Screw	1	100277
5660	Pump Head (N1)	1	000298
	Pump Head (N3)	1	000299
	Pump Head (N4)	1	000300
5663	Pump Body R.H.	1	000297
5666	Anti-Siphon Spring (N1, N3)	1	000340
	Anti-Siphon Spring (N4)	1	000341
5668-A	Std. Motor Assembly 37 SPM**	1	002404
	Std. Motor Assembly 72 SPM**	1	002405
	Std. Motor Assembly 117 SPM**	1	002406
N 5691	Ball Guide (N1, N3)	3	001260
	Ball Guide (N4)	3	001261
N 5693	Stack Spacer (N1, N3)	1	002828
	Stack Spacer (N4)	1	002829
N 5695	Valve Seat (N1, N3)	4	002831
	Valve Seat (N4)	4	002832
5697	Gasket or Sealer* Oil Head	1	106292
5699	Sealing Nut O-Ring	1	100417

\* Silicone Sealant may be substituted for Gasket

"N" indicates parts per new version

\*\* Includes Part Nos. 506, 508 and 509. 1/2-1-115-60-TEFC-CAP-48Y.

Valve stacks of all Series 560 (except PVC models) have been **improved** by the attention of close tolerance ball guides which allow for better accuracy and higher pressure performance.

**Improved** stack arrangements are shown in the figures on page #15.

Parts are currently furnished only for the **improved** version. When ordering replacement seats for an **original** valve stack design, order the ball guides (FIG. #5691) and spacer (FIG. #5693). Installing these parts and discarding the old spacers (FIG. #2320 and FIG. #2326) will upgrade the pump to the **improved** valve arrangement. (Refer to the drawing on page#15)

If seats are not replaced, it is not necessary to change the spacers and ball guides. If seats are replaced (the new seals are of a different thickness) the ball guides and spacers **must** be replaced.

15.0.1 PARTS LIST FOR SERIES.560 "dia-PUMP"

FOR OLD STYLE PVC HEAD Pump Serial Number < or = 147994				FOR NEW STYLE PVC HEAD REFFER DWG. PAGE#20 Pump Serial Number > or = 147995			
Fig #	Description	Part#	Qty	Fig#	Description	Part#	Qty
2337	Vent Plug/cross Connection "0" Ring	100325	2				
5619	Head Retainer Plate (SS)	000319	1	1	Liquid (Pump) Head	004159	1
5621	Pump Head Diaphragm Chamber	000318	1	2	Check Valve Assemblies	004165	2
5622	Pump Head Backup Plate	000330	1	3	Hex Head Cap Screws	107766	8
5623	Vent Plug	000331	1	4	Flat Washers	106857	8
5624	Valve Seat	000332	2				
5625	Discharge Cap	000321	1				
5626	Suction Cap	000322	1	FOR NEW STYLE KYNAR HEAD REFER DWG PAGE#20 Pump Serial Number > or = 147995			
5627	Anti-Siphon Spring	000339	1				
5628	Discharge & Suction Cap "0" Ring	100274	2	1	Liquid (Pump) Head	004160	1
5630	Valve Seat "0" Ring	100273	2	2	Check Valve Assemblies	004166	2
5633	Spacer	000325	4	3	Hex Head Cap Screws	107766	8
5635	Washer	100069	2	4	Flat Washers	106857	8
5638	Upper Spacer	000334	1				
5639	Spacer	000336	1				
5642	Suction Ball Retainer & Spacer	000338	1				
5643	Valve Body Screw - 5/16" x 4 1/2" Lg.	100249	2				
5645	Valve Body Screw - 5/16" x 2 1/4" Lg.	100279	6				
5646	Valve Body Screw - 1/4" x 2 1/4" Lg.	108100	2				
5649	Valve Ball	100275	2				
5667	Valve Body Assembly	002188	1				

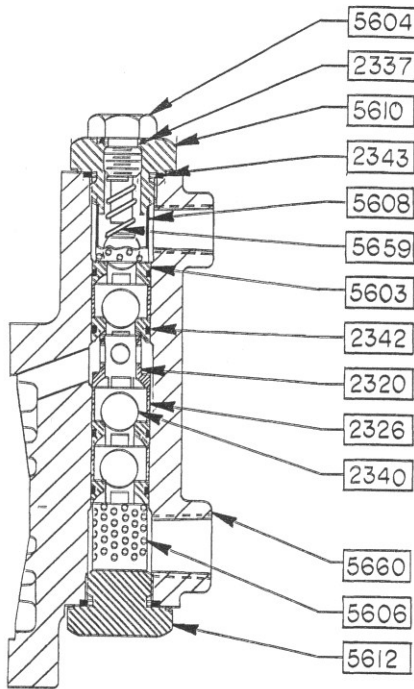

ORIGINAL VALVE STACK

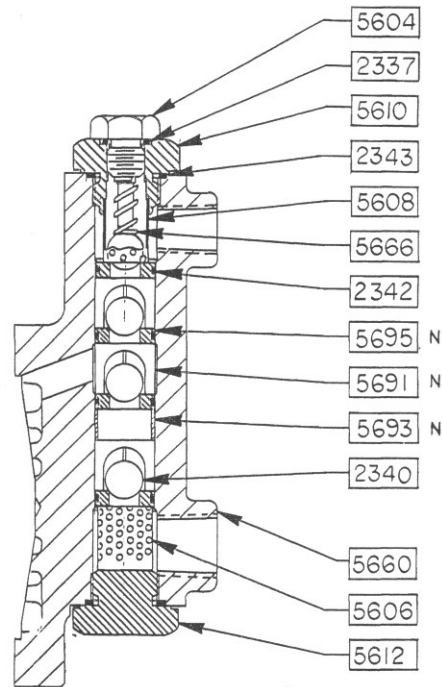

VALVE STACK WITH IMPROVED GUIDES

(N—Indicates new part)

**PARTS ORDERING INSTRUCTIONS**

**Note: For prompt entry of parts orders: your order must include both model and serial numbers.**

15.0.2 RECOMMENDED SPARE PARTS:

IMPORTANT: When ordering spare parts, please show MODEL NUMBER AND SERIAL NUMBER of pump for which parts are being ordered. This information can be found on a stainless steel nameplate riveted to the side of the pump.

Recommended Spare Parts (for metal head "dia-PUMP"). It is recommended that the following parts be kept in stock for a pump:

FIG. #	DESCRIPTION	Kit #002719 - Fits all "N1/N3" Models		Kit NO.002720 - Fits all "N4" Models	
		Qty	Part NO.	Qty	Part NO.
516-C	Sealing Plate "0" Ring	2	100186	2	100186
2310	Teflon Diaphragm	1	000388	1	000388
2334	Control Rod "0" Ring	2	100323	2	100323
2337	Vent Plug "0" Ring	2	100325	2	100325
2340	Valve Ball (316SS) or Valve Ball (C-20)	4	100078	4	100079
2342	Valve Seat 0" Ring	8	100327	8	100327
2343	Discharge & Suction cap "0" Ring	4	100328	4	100328
5695	Valve Seat (316SS) or Valve Seat (C-20)	4	002831	4	002832

15.0.3 RECOMMENDED SPARE PARTS FOR PVC and KYNAR HEAD "dia-PUMP"

**Pump Serial Number > or = 147995**

See PVC and Kynar Head Option on Page 20

FIG. #	DESCRIPTION	Kit #004384 for PVC Head		Kit #004385 for KYNAR Head	
		Part #	Qty.	Part #	Qty.
5 (Page#20)	Teflon Diaphragm	000388	1	000388	1
2 (Page#20)	Check Valve Assembly	004165	2	004166	2
516-C (Page#18)	Sealing Plate "0" Ring	100186	2	100186	2
2334 (Page#18)	Control Rod "0" Ring	100323	2	100323	2

Recommended Spare Parts (for PVC head "dia-PUMP). OLD STYLE (BEFORE JUNE 2004)

**Pump Serial Number < or = 147994**

FIG. #	DESCRIPTION	Kit #002721 - Fits all "N5" OLD Models	
		Qty	Part #.
516-C	Sealing Plate .0" Ring	2	100186
2310	Teflon Diaphragm	1	000388
2334	Control Rod .0" Ring	2	100323
5624	Vent Plug "0" Ring	2	100322
5628	Discharge & Suction cap "0" Ring	4	100274
5629	Vent Plug "0" Ring	2	100272
5630	Valve Seat "0" Ring	4	100273
5649	Valve Ball Ceramic	2	100275

**PARTS ORDERING INSTRUCTIONS**

**Note: For prompt entry of parts orders: your order must include both model and serial numbers.**

15.0.4 PARTS FOR "dia..PUMP" ORDERED WITH OTHER THAN STANDARD INTEGRALLY MOUNTED MOTOR (REFER TO DRAWING #000911 on page#19)

The following groups of parts are sometimes referred to as a motor conversion set. These parts allow the "dia-PUMP to accept any standard 56C frame motor.

FIG. #	DESCRIPTION	QTY.	PART #
506	Worm 37 SPM	1	000170
	Worm 72 SPM	1	000172
	Worm 117 SPM	1	000169
	Worm 144 SPM	1	002817
507	Bearing Cup	1	100179
508	Bearing Cone	1	100180
509	Worm Spring Pin	1	100181
558	Motor Flange Adapter	1	000227
559	Worm Shaft	1	000228
560	Lovejoy Coupling	1	100053
561	Oil Seal	1	100214
562	Adapter to Gear Box Bolts	4	100215
563	Adapter to Motor Bolts	4	100216
564	Lock Washer	4	100217
565	Coupling Key	2	100218
566	Lock Washer	4	100219
	Silicone Sealant	1	

### PARTS ORDERING INSTRUCTIONS

**Note: For prompt entry of part orders, your order must include both model number and serial number**

SECTION VII

DRAWINGS

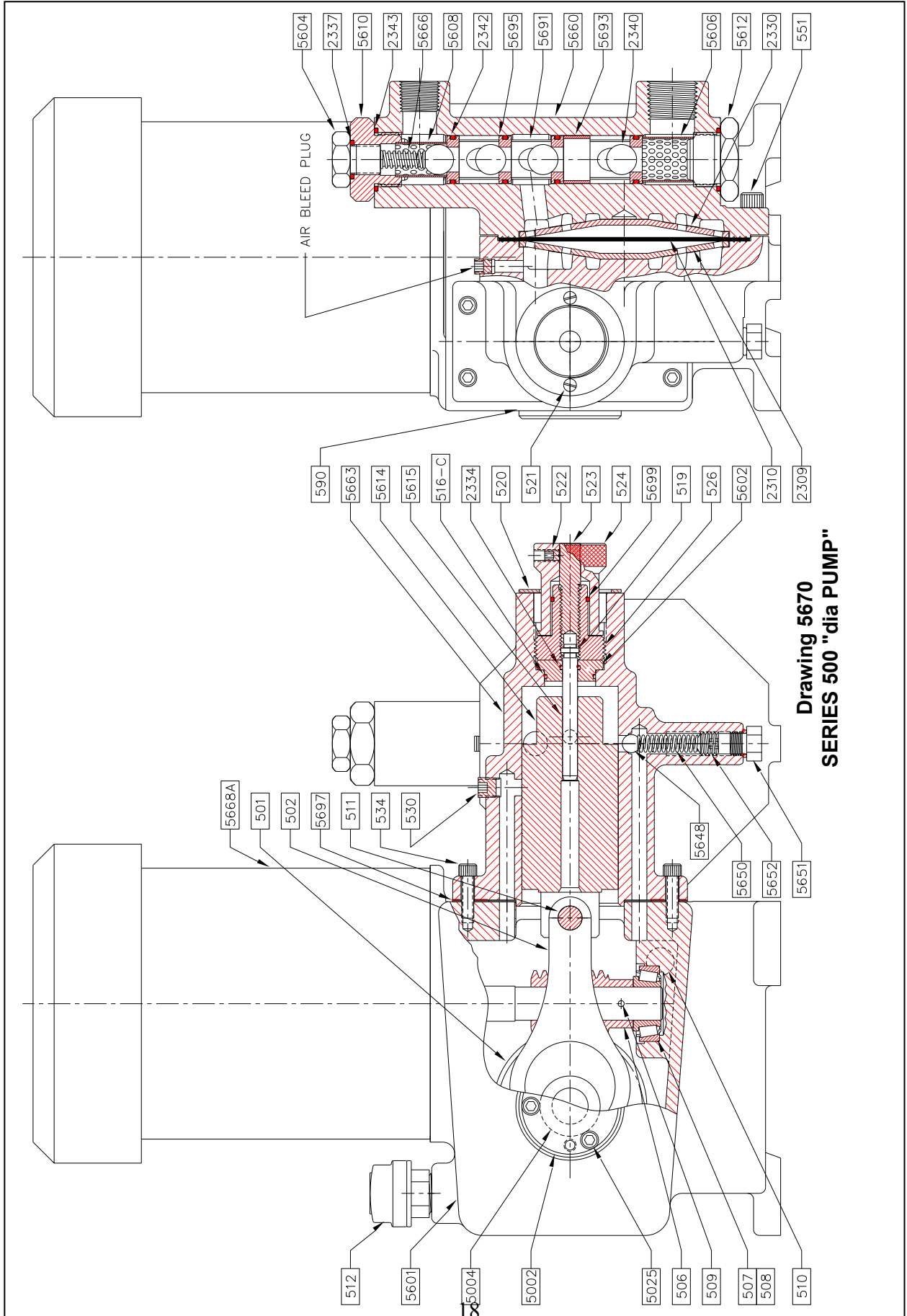

**Drawing 5670**  
**SERIES 500 "dia PUMP"**

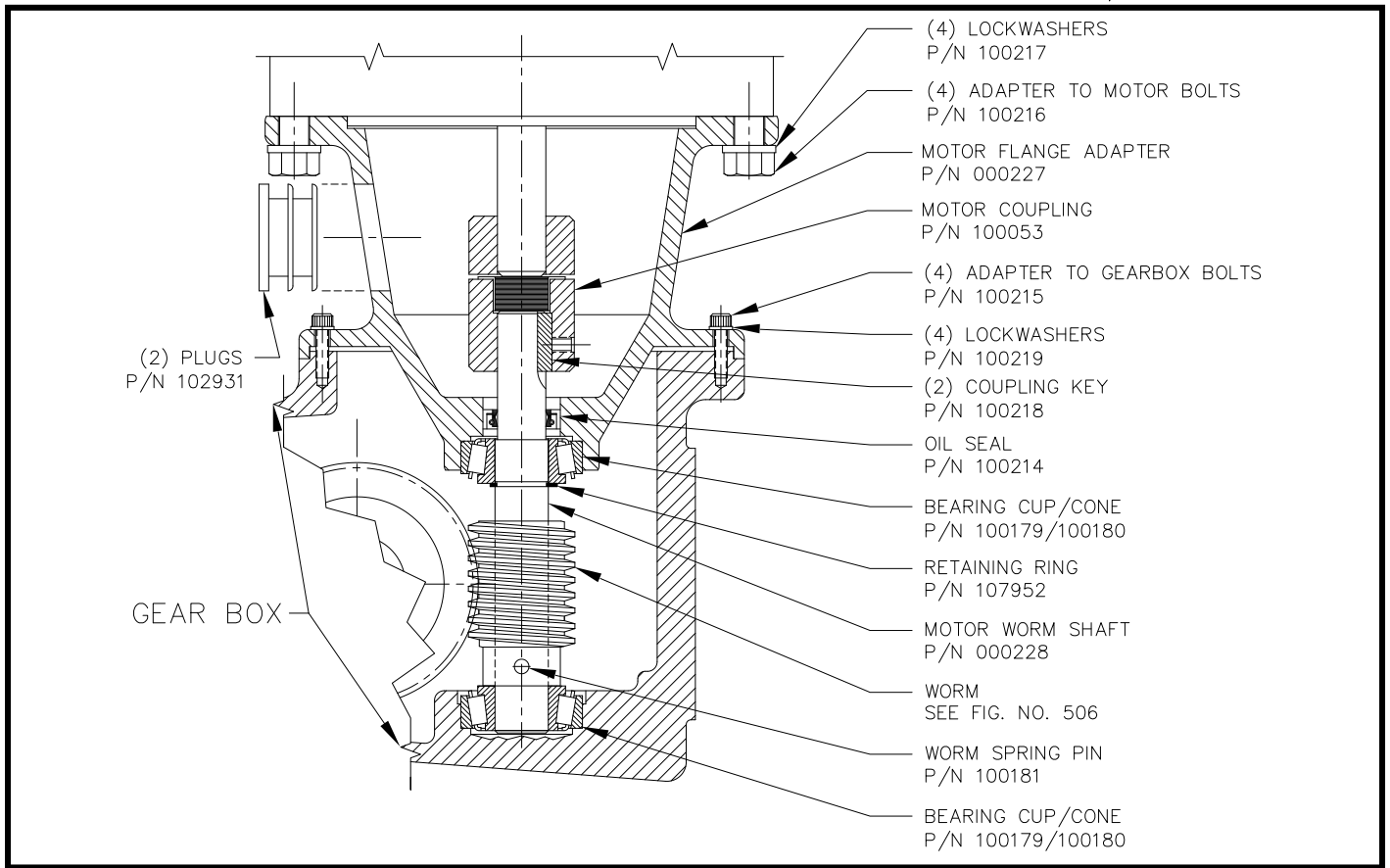

DRAWING #000911

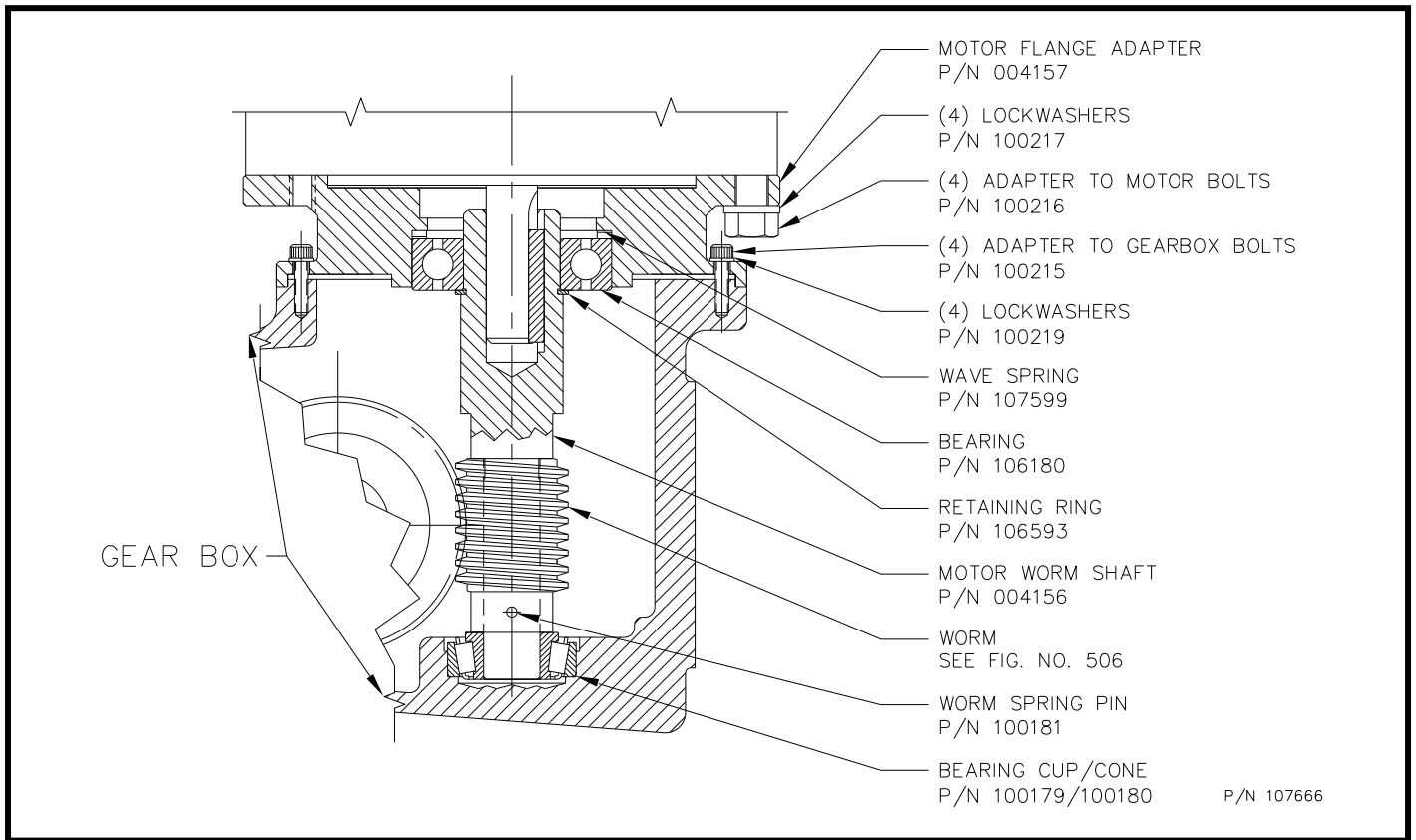

DRAWING # FALP

# PVC AND KYNAR HEAD OPTION

This sheet describes the parts, which are unique to the 560 pumps with the PVC and Kynar Heads.

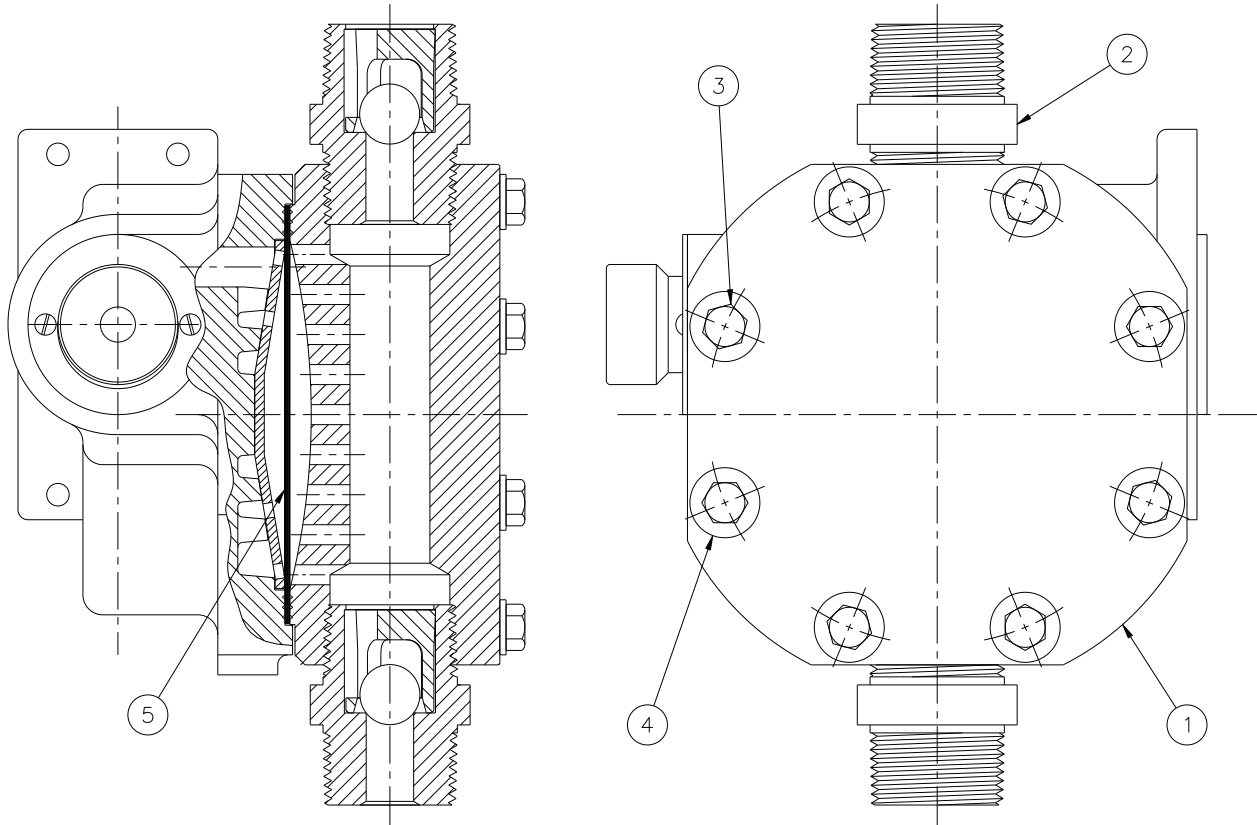

Item No.	Description	Qty	PVC Part No.	Kynar Part No.
1	Liquid Head (Pump Head)	1	004159	004160
2	Check Valve Assemblies	2	004165	004166
3	Hex Head Cap Screws	8	107766	107766
4	Flat washers	8	106857	106857
5	Diaphragm	1	000388	000388



## THEORY OF OPERATION

The instructions below are for Neptune’s optional Double Diaphragm Kit which is available for the Neptune Series 560 “dia-PUMPs”.

Use of a double diaphragm allows diaphragm to be monitored and provides an early warning upon failure of either diaphragm allowing repairs to be made before process fluid mix with the pump hydraulic fluid.

Neptune’s double diaphragm is a kit which may be retrofitted to any pump currently in service or may be installed on a new pump at the factory.

**Figure 1** illustrates a Double Diaphragm Assembly. An intermediate plate is located between the oil and liquid heads with one diaphragm on each side of the intermediate plate. The Intermediate Plate is connected to a rupture alarm or pressure switch via a capillary system. The area between the diaphragms is evacuated. Rupture in either diaphragm produces an increase in volume and, therefore, a pressure increase, which can be sensed by a pressure switch for alarm purposes.

### DISASSEMBLY OF INTERMEDIATE PLATE

- 1.0.0 Shut pump off and disconnect suction and discharge piping. Remove drain plug and drain hydraulic fluid from the gearbox.
- 1.0.1 Remove 8 Screws and remove the liquid head assembly. Some hydraulic oil and process fluid will spill out when the head is removed.
- 1.0.2 The intermediate plate, which is between the pump heads can be removed easily.
- 1.0.3 Remove the rupture alarm (pressure switch) and clean the capillary system.
- 1.0.4 Replace one or both diaphragms if needed.
- 1.0.5 To reassemble reverse above procedure. Be certain that parts align properly.

### VACUUM AIR FROM INTERMEDIATE SPACE

- 1.0.6 Open valve Item No. 5 (**Figure 2**).
- 1.0.7 To remove air, attach the vacuum pump with a hose connection Item No. 6 to the valve Item No. 5 (**Figure 5**) and pump **until resistance is felt**, for normal operating conditions.

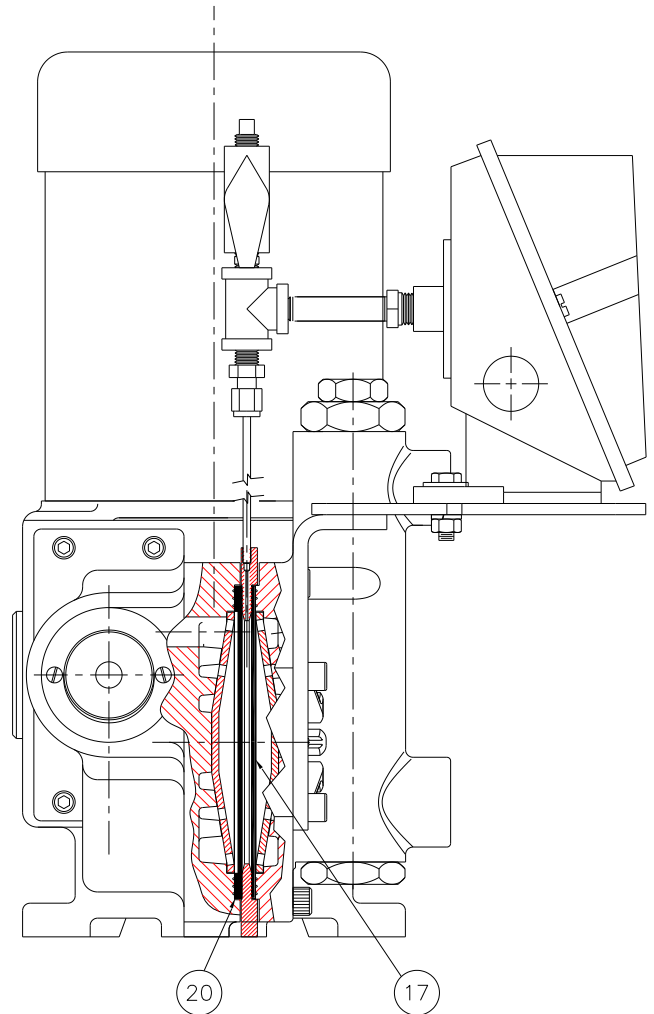

**FIGURE 1**

## APPENDIX

# DOUBLE DIAPHRAGM OPTION

ADDENDUM: Special instructions for Series 500, 500-A & 560 “dia-PUMPs” with Double Diaphragm

- 1.0.8 Close valve Item No. 5
- 1.0.9 Remove the vacuum pump. Plug valve Item No. 5 with a 316SS pipe plug Item No. 12
- 1.0.10 Reinstall the Pump
- 1.0.11 Follow procedure in Neptune Standard Operating and Instruction Manual for Initial Pump Startup

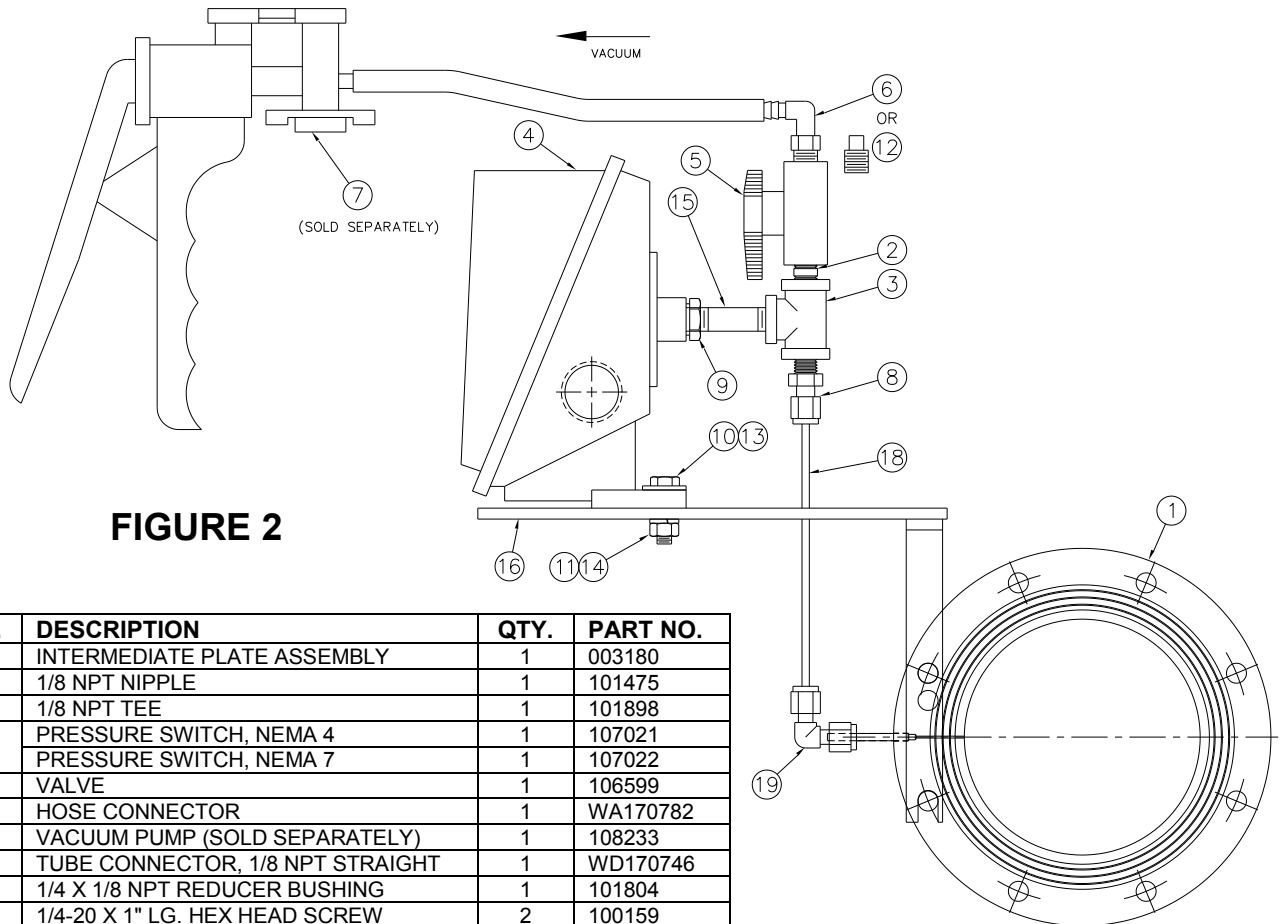

**FIGURE 2**

ITEM NO.	DESCRIPTION	QTY.	PART NO.
1	INTERMEDIATE PLATE ASSEMBLY	1	003180
2	1/8 NPT NIPPLE	1	101475
3	1/8 NPT TEE	1	101898
4	PRESSURE SWITCH, NEMA 4	1	107021
	PRESSURE SWITCH, NEMA 7	1	107022
5	VALVE	1	106599
6	HOSE CONNECTOR	1	WA170782
7	VACUUM PUMP (SOLD SEPARATELY)	1	108233
8	TUBE CONNECTOR, 1/8 NPT STRAIGHT	1	WD170746
9	1/4 X 1/8 NPT REDUCER BUSHING	1	101804
10	1/4-20 X 1" LG. HEX HEAD SCREW	2	100159
11	1/4-20 HEX NUT	2	100448
12	1/8 NPT PIPE PLUG, 316SS	1	101859
13	1/4" FLAT WASHER	2	108426
14	1/4" LOCK WASHER	2	100169
15	1/8 NPT NIPPLE (FOR METAL HEADS)	1	101477
	1/8 NPT NIPPLE (FOR PLASTIC HEADS)	1	101479
16	BRACKET ASSEMBLY	1	003577
	BRACKET ASSEMBLY (FOR DUPLEX)	1	003600
17	DIAPHRAGM	1	000388
18	VACUUM TUBE	1	004433
19	TUBE CONNECTOR, 1/8 NPT ELBOW	1	104614
20	TEFLON WASHER	1	003173

**NOTE:** Neptune furnishes a Mityvac<sup>®</sup> vacuum pump from Mityvac<sup>®</sup> No. 6810 automotive test kit available at many automotive parts stores. (Unit furnished by Neptune is less gage and automotive adapters)



## EC Declarations for Diaphragm Metering Pumps

---

Manufacturer:

PSG California

22069 Van Buren Street

Grand Terrace, CA 92313 USA

Director of Engineering: Chris Distaso

Signature:

Representative authorized to compile technical files in the European Community:

ALMATEC Maschinenbau GmbH

Carl-Friedrich-Gauß-Straße 5

D - 47475 Kamp-Lintfort Germany

General Manager: Rainer Wulf

Signature:

---

Product: Neptune Diaphragm Metering Pump Models Series 400, 500, 600, 6000, 7000

Date: 05/22/2019

Serial Number: As Applicable

---

### DECLARATION OF INCORPORATION *(Valid for pumps supplied without a motor)*

Neptune declares that the products listed above comply with the essential health and safety requirements relevant to the specific product as follows: All Neptune products listed above conform to the Machinery Directive 2006/42/EC: Part 1 of Annex I and comply with the relevant requirements of EN ISO 12100 Safety of Machinery - General Principles for Design - Risk Assessment and Risk Reduction, and DIN EN 809 Pumps and Pump Units for Liquids - Common Safety Requirements.

This subassembly is incomplete and must not be put into service until the machinery into which it is to be incorporated has been declared in conformity with the provisions of Directive 2006/42/EC ("The Machinery Directive") and any other applicable Directives.

---

### DECLARATION OF CONFORMITY *(Valid for pumps supplied with a motor)*

Neptune declares that the products listed above comply with the essential health and safety requirements relevant to the specific product as follows: All Neptune products listed above conform to the Machinery Directive 2006/42/EC: Part 1 of Annex I and comply with the relevant requirements of EN ISO 12100 Safety of Machinery - General Principles for Design - Risk Assessment and Risk Reduction, DIN EN 809 Pumps and Pump Units for Liquids - Common Safety Requirements, and DIN EN ISO 4871 - Declaration and Verification of Noise Emission Values of Machinery and Equipment. The supplied motor conforms to the 2014/35/EU - The Low Voltage Directive *(compliance exists from the motor manufacturer)*.

This product **may not be used** in an explosive environment.



Revision 1  
Revision 2  
Revision 3 8-10-2012  
Revision 4 2-14-2013  
Revision 5, ECN-3255 (5/18/2015)  
Revision 6, (3/13/2018)