

EOM

ENGINEERING OPERATION
& MAINTENANCE

A2 Accu-Flo Clamped Plastic Pump

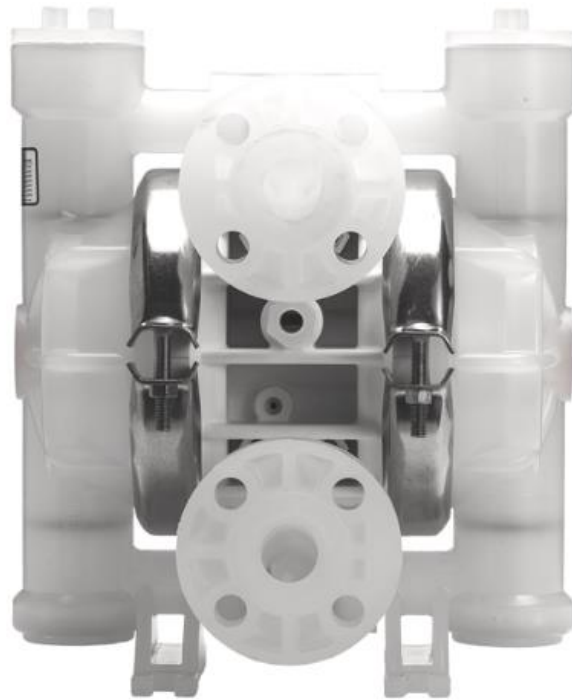

Where Innovation Flows

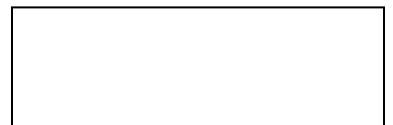

WIL-10070-E-03

Contents

| | |
|--|-----------|
| Section 1: Precautions - Read First! | 4 |
| Section 2: Wilden Pump Designation System | 5 |
| Section 3: How It Works | 6 |
| Section 4: Dimensional Drawings | 7 |
| A2T Plastic (T-series Center Section)..... | 7 |
| A2B Plastic (Adapter Block with T-series Center Section)..... | 7 |
| A2P Plastic (P-series Center Section)..... | 8 |
| A2B Plastic (Adapter Block with P-series Center Section)..... | 8 |
| Section 5: Performance | 9 |
| A2T Plastic Rubber-Fitted (T-series Center Section)..... | 9 |
| A2T Plastic PTFE-Fitted (T-series Center Section)..... | 9 |
| A2P Plastic Rubber-Fitted (P-series Center Section)..... | 10 |
| A2P Plastic PTFE-Fitted (P-series Center Section)..... | 10 |
| 70/30 Operating Conditions | 11 |
| A2T Plastic Rubber-Fitted (T-Series Center Section)..... | 11 |
| A2T Plastic PTFE-Fitted (T-Series Center Section)..... | 11 |
| A2P Plastic Rubber-Fitted (P-Series Center Section)..... | 11 |
| A2P Plastic PTFE-Fitted (P-Series Center Section)..... | 11 |
| Section 6: Suggested Installation, Operation, Maintenance and Troubleshooting | 12 |
| Section 7: Disassembly / Reassembly | 15 |
| Pump Disassembly..... | 15 |
| Reassembly Hints & Tips..... | 18 |
| Section 8: Exploded View and Parts List | 19 |
| A2T Plastic (T-series Center Section)..... | 19 |
| A2P Plastic (P-series Center Section)..... | 21 |
| Section 9: Elastomer Options/Electrical Information | 23 |

Copyright

Copyright 2018 PSG®, a Dover Company. All rights reserved.

PSG reserves the right to modify the information and illustrations in this document without prior notice. The product described in this document is furnished under a license agreement or nondisclosure agreement. No part of this document may be reproduced, stored in a retrieval system, or transmitted in any form or any means electronic or mechanical, including photocopying and recording, without the written permission of PSG, a Dover Company, except as described by the terms of those agreements.

This is a non-contractual document. 01-2019.

Trademarks

PSG and the PSG logo are registered trademarks of PSG. Wilden® is a registered trademark of PSG California LLC. Pro-Flo® SHIFT and Pro-Flo® are registered trademarks of PSG California LLC. Wil-Flex® is a trademark of PSG California LLC. Saniflex™ is a trademark of PSG California LLC.

All trademarks, names, logos and service marks (collectively "trademarks") in this document are registered and unregistered trademarks of their respective owners. Nothing contained in this document should be construed as granting any license or right to use any trademark without the prior written permission of the trademark owner.

Warranty

Each and every product manufactured by Wilden is built to meet the highest standards of quality. Every pump is functionally tested to insure integrity of operation. Wilden warrants that pumps, accessories and parts manufactured or supplied by it to be free from defects in material and workmanship for a period of five (5) years from date of installation or six (6) years from date of manufacture, whichever comes first.

For more information, and to register your Wilden pump for warranty, please visit <https://www.psgdover.com/wilden/support/warranty-registration>.

Certifications

Section 1

Precautions - Read First!

 **TEMPERATURE LIMITS:**

| | | |
|---------------|--------------------|----------------|
| Polypropylene | 0°C to 79°C | 32°F to 175°F |
| PVDF | -12°C to 107°C | 10°F to 225°F |
| Neoprene | -17.8°C to 93.3°C | 0°F to 200°F |
| Buna-N | -12.2°C to 82.2°C | 10°F to 180°F |
| EPDM | -51.1°C to 137.8°C | -60°F to 280°F |
| FKM | -40°C to 176.7°C | -40°F to 350°F |
| Wil-Flex™ | -40°C to 107.2°C | -40°F to 225°F |
| Polyurethane | 12.2°C to 65.6°C | 10°F to 150°F |
| Saniflex™ | -28.9°C to 104.4°C | -20°F to 220°F |
| PTFE | 4.4°C to 104.4°C | 40°F to 220°F |
| Polypropylene | 0°C to 79°C | 32°F to 175°F |
| PVDF | -12°C to 107°C | 10°F to 225°F |

NOTE: Not all materials are available for all models. See "Wilden Pump Designation System on page 5 for material options for your pump.

 **CAUTION:** When choosing pump materials, be sure to check the temperature limits for all wetted components. Example: FKM® has a maximum limit of 176.7°C (350°F) but polypropylene has a maximum limit of only 79°C (175°F).

 **CAUTION:** Maximum temperature limits are based upon mechanical stress only. Certain chemicals will significantly reduce maximum safe operating temperatures. Consult engineering guide for chemical compatibility and temperature limits.

 **CAUTION:** Always wear safety glasses when operating pump. If diaphragm rupture occurs, material being pumped may be forced out air exhaust.

 **WARNING:** Prevention of static sparking — If static sparking occurs, fire or explosion could result. Pump, valves, and containers must be properly grounded when handling flammable fluids and whenever discharge of static electricity is a hazard.

 **CAUTION:** Do not exceed 8.6 bar (125 psig) air supply pressure.

 **CAUTION:** Plastic series pumps are made of virgin plastic and are not UV stabilized. Direct sunlight for prolonged periods can cause deterioration of plastics.

 **CAUTION:** Before any maintenance or repair is attempted, the compressed air line to the pump should be disconnected and all air pressure allowed to bleed from pump. Disconnect all intake, discharge and air lines. Drain the pump by turning it upside down and allowing any fluid to flow into a suitable container.

 **CAUTION:** Blow out air line for 10 to 20 seconds before attaching to pump to make sure all pipe line debris is clear. Use an in-line air filter. A 5µ (micron) air filter is recommended.

 **NOTE:** Tighten clamp bands and retainers prior to installation. Fittings may loosen during transportation.

 **NOTE:** When installing PTFE diaphragms, it is important to tighten outer pistons simultaneously (turning in opposite directions) to ensure tight fit.

 **NOTE:** Before starting disassembly, mark a line from each liquid chamber to its corresponding air chamber. This line will assist in proper alignment during reassembly.

 **CAUTION:** Verify the chemical compatibility of the process and cleaning fluid to the pump's component materials in the Chemical Resistance Guide (see RBG E4).

 **CAUTION:** Only explosion proof (NEMA 7) solenoid valves should be used in areas where explosion proof equipment is required

 **CAUTION:** Do not lubricate lube-free pumps.

 **CAUTION:** The A2 pump is not submersible.

 **NOTE:** When reinstalling the outer pistons, apply two (2) drops of Loctite® 246 to the shaft internal threads before the diaphragm assembly.

Section 2

WILDEN PUMP DESIGNATION SYSTEM

A2 PLASTIC

LEGEND

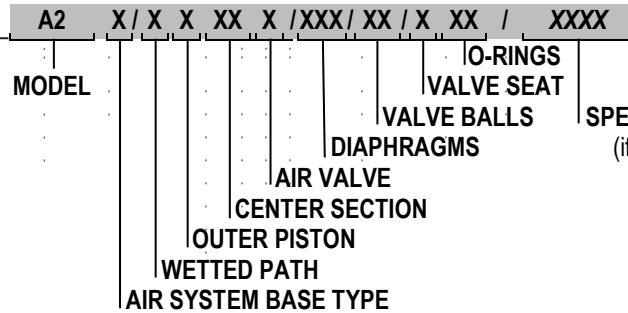

MATERIAL CODES

MODEL
A2 = PLASTIC ACCU-FLO™

AIR SYSTEM BASE TYPE
B = ADAPTER BLOCK
P = PRO-FLO®
T = TURBO-FLO™

WETTED PATH
K = PVDF
P = POLYPROPYLENE

OUTER PISTON
K = PVDF
P = POLYPROPYLENE

CENTER SECTION
PP = POLYPROPYLENE

AIR VALVE
A = ALUMINUM (available on A2T only)
P = POLYPROPYLENE
U = UHMW PE (available on A2B only)

DIAPHRAGMS
BNS = BUNA-N (Red Dot)
EPS = EPDM (Blue Dot)
FSS = SANIFLEX™ [Hytre® (Cream)]
NES = NEOPRENE (Green Dot)
PUS = POLYURETHANE (Clear)
TEU = PTFE W/EPDM BACK-UP (White)
TNU = PTFE W/NEOPRENE BACK-UP (White)
TSU = PTFE W/SANIFLEX™ BACK-UP (White)
VTS = FKM (White Dot)
WFS = WIL-FLEX™ [Santoprene® (Orange Dot)]

VALVE BALLS
BN = BUNA-N (Red Dot)
EP = EPDM (Blue Dot)
FS = SANIFLEX™ [Hytre® (Cream)]
NE = NEOPRENE (Green Dot)
PU = POLYURETHANE (Brown)
TF = PTFE (White)
VT = FKM® (White Dot)
WF = WIL-FLEX™ [Santoprene® (Orange Dot)]

VALVE SEATS
K = PVDF
P = POLYPROPYLENE

VALVE SEAT O-RINGS
BN = BUNA-N
PU = POLYURETHANE (Brown)
TV = PTFE ENCAP. FKM®
WF = WIL-FLEX™ [Santoprene®]

SPECIALTY CODES

| | | |
|--|--|--|
| 0261 A2 Plastic, Accu-Flo™, 24V AC / 12V DC coil | 0525 Ultrapure II, Female Connections, PFA-coated hardware, Wil-Gard II™ sensor wires ONLY | 0457 A2 Plastic, Accu-Flo™, 24V DC coil, SS outer pistons, DIN flange |
| 0262 A2 Plastic, Accu-Flo™, 24V AC / 12V DC x-proof coil | 0362 Accu-Flo™, 110V AC coil, PFA coated hardware, Wil-Gard II™ 110V | 0458 A2 Plastic, Accu-Flo™, 24V DC coil, Wil-Gard II™ 220V, DIN flange |
| 0263 A2 Plastic, Accu-Flo™, 24V DC coil | 0451 A2 Plastic, Accu-Flo™, no coil, DIN flange | 0567 Split manifold, Accu-Flo™, 24V DC coil |
| 0264 A2 Plastic, Accu-Flo™, 24V DC x-proof coil | 0454 A2 Plastic, Accu-Flo™, 24V DC coil, DIN flange | 0570 Split manifold, Accu-Flo™, 24V AC / 12V DC coil |
| 0265 A2 Plastic, Accu-Flo™, 110V AC coil | 0455 A2 Plastic, Accu-Flo™, 24V AC / 12V DC coil, DIN flange | 0509 adapter block, no muffler, P2R center section |
| 0266 A2 Plastic, Accu-Flo™, 110V AC x-proof coil | 0456 A2 Plastic, Accu-Flo™, 24V DC, Intl. x-proof coil, DIN flange | 0518 adapter block, no muffler, T2R center section |
| 0271 A2 Plastic, Accu-Flo™, 110V AC coil, Wil-Gard II™ 110V | | |
| 0272 A2 Plastic, Accu-Flo™, 24V AC / 12V DC coil, SS outer pistons | | |
| 0273 A2 Plastic, Accu-Flo™, 24V DC coil, Wil-Gard II™ 110V | | |

THE THREE ACCU-FLO™ OPTIONS AVAILABLE:

1. AxT: This is the same Accu-Flo™ configuration that has been available from Wilden since March 1994. An aluminum solenoid valve is attached directly to a T-series center section and the shaft/inner piston configuration is altered.
2. This option uses a plastic (polypropylene or acetal) spacer that is assembled between the Pro-Flo® air valve and the Pro-Flo® center section. The same solenoid operator – coil assembly that is found on AxT pumps is assembled on the plastic spacer discussed above for electronic interface. This spacer combined with the Pro-Flo® air valve replaces the aluminum air valve used in the AxT with a more chemically resistant option. Spacers will be available in the 1/4", 1/2", and 1" sizes.

NOTE: Most elastomeric materials use colored dots for identification.
NOTE: Not all models are available with all material options.

The use of the Pro-Flo® ADS provides additional flow in most applications (refer to EOM for details). The AxP provides the Pro-Flo® benefits of lower start-up pressure, reduced blow-by, and increased life.

3. AxB: This option uses an Adapter Block in place of an air valve. A user supplied, 4-way pneumatic valve must be used in conjunction with this technology. This configuration enables the solenoid valve to be remotely installed, preventing chemical attack in very aggressive environments. Adapter Blocks are available for both the T and P-series center sections in all pump sizes. (See EOM AxB for details.)

NOTE: the "x" in the above Accu-Flo™ descriptions are used in place of a pump model size. See Pump Designation System chart above.

Hytre® is a registered trademark of DuPont Dow Elastomers.
Santoprene® is a registered trademark of Monsanto Company, licensed to Advanced Elastomer Systems, L.P.

Section 3

HOW IT WORKS — PUMP

The Wilden diaphragm pump is an air-operated, positive displacement, self-priming pump. These drawings show the flow pattern through the pump upon its initial stroke. It is assumed the pump has no fluid in it prior to its initial stroke.

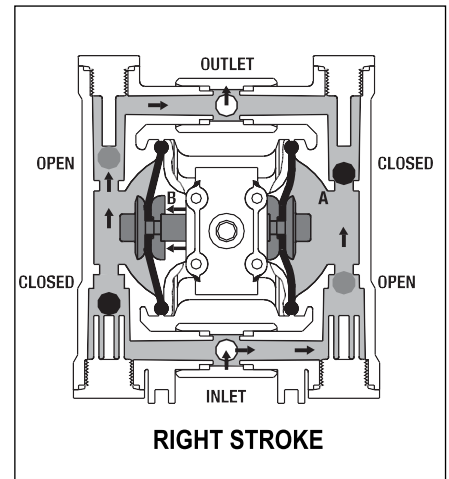
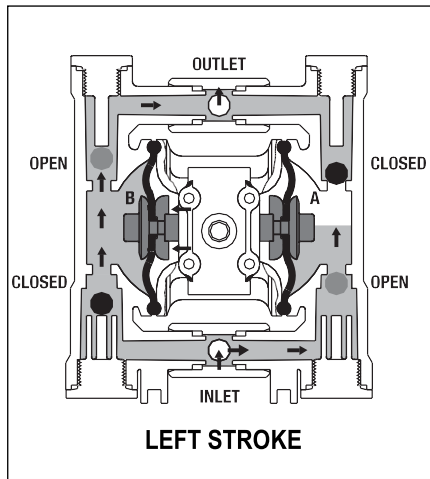
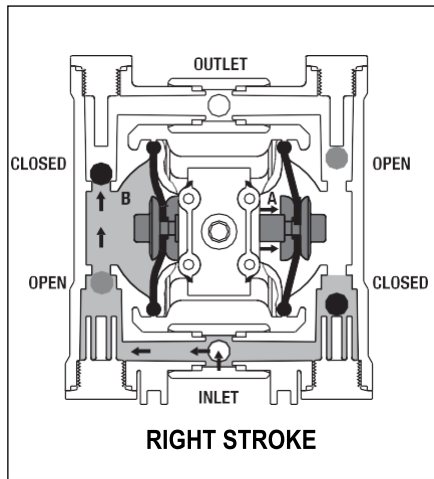

FIGURE 1 When the solenoid is energized, the air valve directs pressure to the back side of diaphragm A. The compressed air is applied directly to the liquid column separated by elastomeric diaphragms. The diaphragm acts as a membrane between the compressed air and the liquid, balancing the load and removing mechanical stress from the diaphragm. The compressed air moves the diaphragm away from the center section of the pump. The opposite diaphragm is pulled in by the shaft connected to the pressurized diaphragm. Diaphragm B is on its suction stroke; air behind the diaphragm has been forced out to the atmosphere through the exhaust port. The movement of diaphragm B toward the center section of the pump creates a vacuum within chamber B. Atmospheric pressure forces fluid into the inlet manifold forcing the inlet valve ball off of its seat. Liquid is free to move past the inlet valve ball and fill the liquid chamber (see shaded area).

FIGURE 2 When the solenoid valve is deenergized, the air valve redirects pressurized air to the back side of diaphragm B. The pressurized air forces diaphragm B away from the center section while pulling diaphragm A to the center section. Diaphragm B is now on its discharge stroke. Diaphragm B forces the inlet valve ball onto its seat due to the hydraulic forces developed in the liquid chamber and manifold of the pump. These same hydraulic forces lift the discharge valve ball off of its seat, while the opposite discharge valve ball is forced onto its seat, forcing fluid to flow through the pump discharge. The movement of diaphragm A toward the center section of the pump creates a vacuum within liquid chamber A. Atmospheric pressure forces fluid into the inlet manifold of the pump. The inlet valve ball is forced off of its seat allowing the fluid being pumped to fill the liquid chamber.

FIGURE 3 Once the solenoid valve is reenergized, the air is directed to the back side of diaphragm A, which starts diaphragm B on its exhaust stroke. As the pump reaches its original starting point, each diaphragm has gone through one intake and one discharge stroke. This constitutes one complete pumping cycle. The pump may take several cycles to completely prime depending on the conditions of the application.

Section 4

DIMENSIONAL DRAWING

A2T Plastic Accu-Flo™

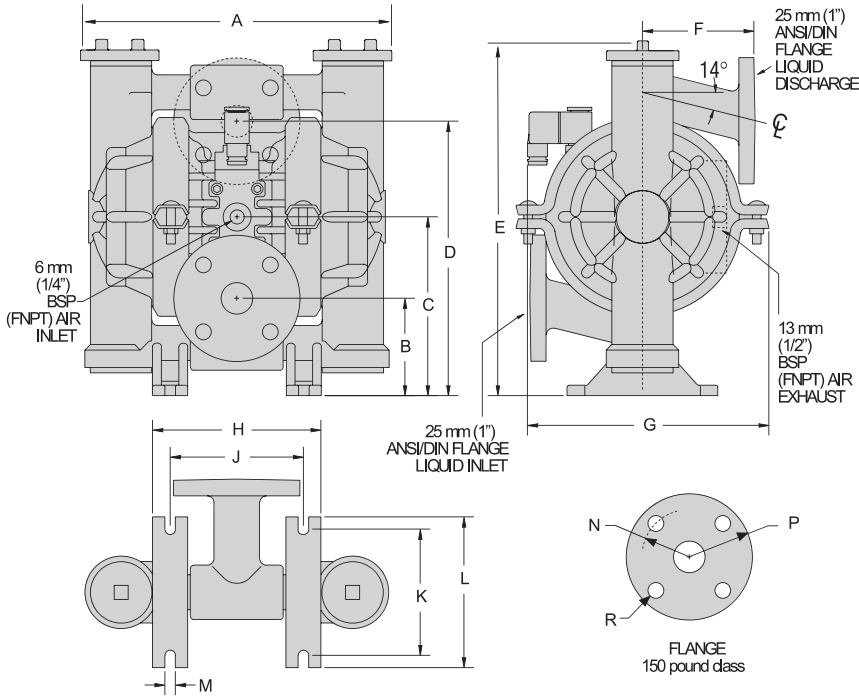

DIMENSIONS

| ITEM | METRIC (mm) | STANDARD (inch) |
|------|-------------|-----------------|
| A | 297 | 11.7 |
| B | 74 | 2.9 |
| C | 163 | 6.4 |
| D | 251 | 9.9 |
| E | 335 | 13.2 |
| F | 107 | 4.2 |
| G | 229 | 9.0 |
| H | 157 | 6.2 |
| J | 124 | 4.9 |
| K | 114 | 4.5 |
| L | 137 | 5.4 |
| M | 10 | 0.4 |
| N | 79 DIA. | 3.1 DIA. |
| P | 109 DIA. | 4.3 DIA. |
| R | 15 DIA. | 0.6 DIA. |

A2B Plastic (T-Series Center Section)

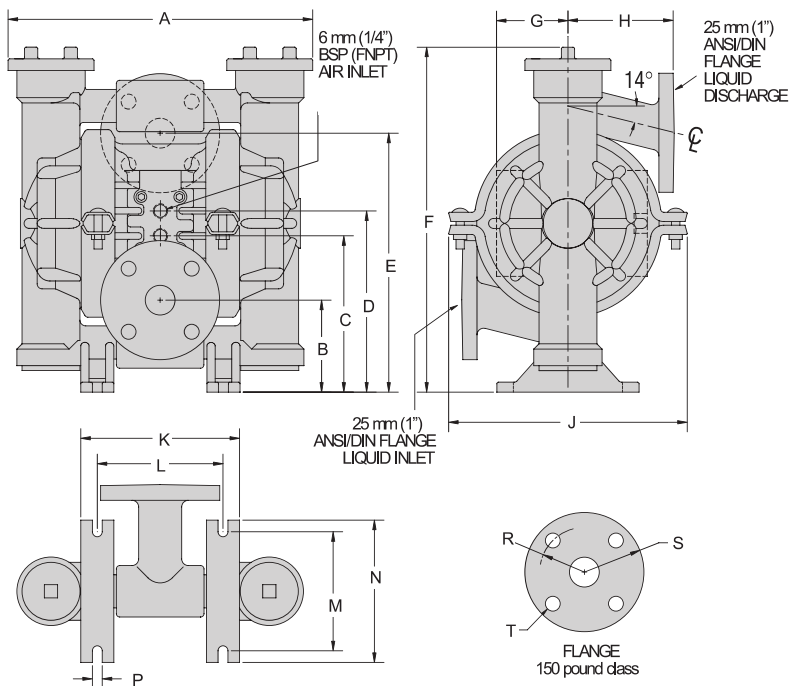

DIMENSIONS

| ITEM | METRIC (mm) | STANDARD (inch) |
|------|-------------|-----------------|
| A | 297 | 11.7 |
| B | 74 | 2.9 |
| C | 150 | 5.9 |
| D | 173 | 6.8 |
| E | 251 | 9.9 |
| F | 335 | 13.2 |
| G | 69 | 2.7 |
| H | 107 | 4.2 |
| J | 239 | 9.4 |
| K | 114 | 4.5 |
| L | 137 | 5.4 |
| M | 124 | 4.9 |
| N | 157 | 6.2 |
| P | 10 | 0.4 |
| R | 79 DIA. | 3.1 DIA. |
| S | 109 DIA. | 4.3 DIA. |
| T | 15 DIA. | 0.6 DIA. |

DIMENSIONAL DRAWING

A2P Plastic Accu-Flo™

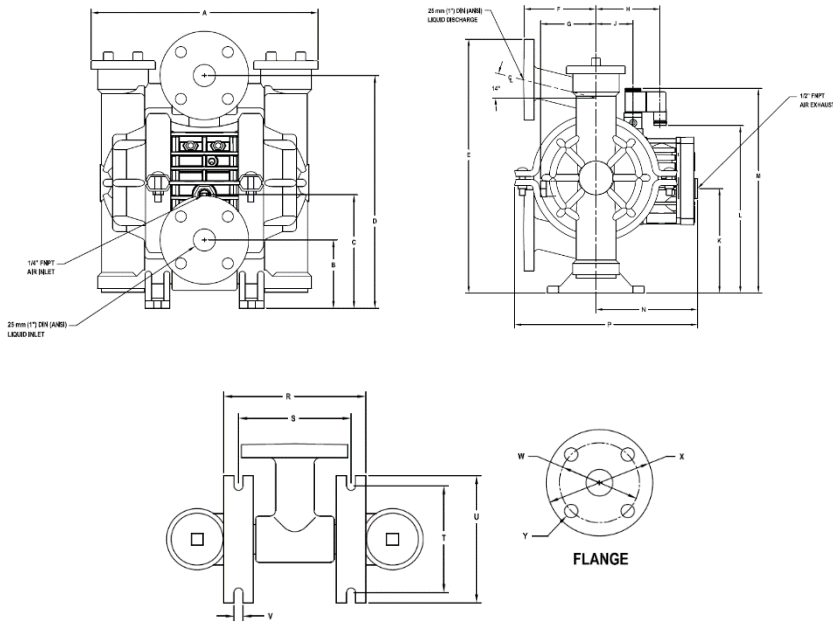

DIMENSIONS

| ITEM | METRIC (mm) | STANDARD (inch) |
|------|-------------|-----------------|
| A | 297 | 11.7 |
| B | 74 | 2.9 |
| C | 147 | 5.8 |
| D | 308 | 12.1 |
| E | 356 | 14.0 |
| F | 107 | 4.2 |
| G | 69 | 2.7 |
| H | 91 | 3.6 |
| J | 53 | 2.1 |
| K | 147 | 5.8 |
| L | 236 | 9.3 |
| M | 287 | 11.3 |
| N | 142 | 5.6 |
| P | 259 | 10.2 |
| R | 157 | 6.2 |
| S | 125 | 4.9 |
| T | 115 | 4.5 |
| U | 138 | 5.4 |
| V | 10 | .4 |
| | DIN | ANSI |
| W | 85 DIA. | 3.1 DIA. |
| X | 115 DIA. | 4.3 DIA. |
| Y | 14 DIA. | .6 DIA. |

LW0409 REV. A

A2B Plastic (P-Series Center Section)

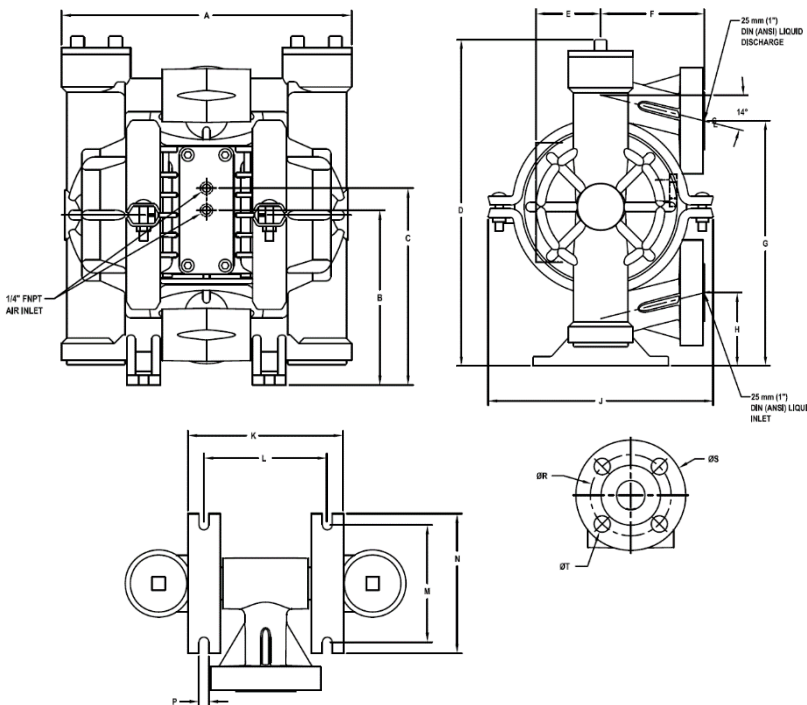

DIMENSIONS

| ITEM | METRIC (mm) | STANDARD (inch) |
|------|-------------|-----------------|
| A | 277 | 10.9 |
| B | 166 | 6.5 |
| C | 187 | 7.4 |
| D | 333 | 13.1 |
| E | 66 | 2.6 |
| F | 107 | 4.2 |
| G | 249 | 9.8 |
| H | 76 | 3.0 |
| J | 124 | 4.9 |
| K | 152 | 6.0 |
| L | 122 | 4.8 |
| M | 114 | 4.5 |
| N | 137 | 5.4 |
| P | 10 | 0.4 |
| | DIN | |
| R | 84 DIA | 3.3 DIA |
| S | 114 DIA | 4.5 DIA |
| T | 15 DIA | .6 DIA |
| | ANSI | |
| R | 79 DIA. | 3.1 DIA. |
| S | 109 DIA. | 4.3 DIA. |
| T | 15 DIA. | 0.6 DIA. |

LW0474 REV. A

Section 5

A2T PLASTIC RUBBER-FITTED

Height 335 mm (13.2")
 Width 297 mm (11.7")
 Depth 239 mm (9.4")
 Est. Ship Weight.....
 Polypropylene 8 kg (18 lbs)
 PVDF 10 kg (23 lbs)
 Air Inlet..... 6 mm (1/4")
 Inlet..... 25 mm (1")
 Outlet 25 mm (1")
 Suction Lift 4.5 m Dry (14.7')
 9.3 m Wet (30.6')
 Disp. Per Stroke¹0.06 l (0.015 gal.)
 Max. Flow Rate..... 95 lpm (25 gpm)
 Max. Size Solids..... 3.2 mm (1/8")

¹Displacement per stroke was calculated at 4.8 bar (70 psig) air inlet pressure against a 2 bar (30 psig) head pressure.

Example: To pump 37.9 lpm (10 gpm) against a discharge pressure head of 3.0 bar (44 psig) requires 4.1 bar (60 psig) and 20.4 Nm³/h (12.0 scfm) air consumption. (See dot on chart.)

Caution: Do not exceed 8.6 bar (125 psig) air supply pressure.

A.025T PLASTIC PTFE-FITTED

Height 335 mm (13.2")
 Width 297 mm (11.7")
 Depth 239 mm (9.4")
 Est. Ship Weight.....
 Polypropylene 8 kg (18 lbs)
 PVDF 10 kg (23 lbs)
 Air Inlet..... 6 mm (1/4")
 Inlet..... 25 mm (1")
 Outlet 25 mm (1")
 Suction Lift 3.5 m Dry (11.3')
 9.3 m Wet (30.6')
 Disp. Per Stroke¹0.05 l (0.014 gal.)
 Max. Flow Rate..... 61 lpm (16 gpm)
 Max. Size Solids..... 3.2 mm (1/8")

¹Displacement per stroke was calculated at 4.8 bar (70 psig) air inlet pressure against a 2 bar (30 psig) head pressure.

Example: To pump 18.95 lpm (5 gpm) against a discharge pressure head of 2.8 bar (40 psig) requires 4.1 bar (60 psig) and 15.3 Nm³/h (9 scfm) air consumption. (See dot on chart.)

Caution: Do not exceed 8.6 bar (125 psig) air supply pressure.

PERFORMANCE

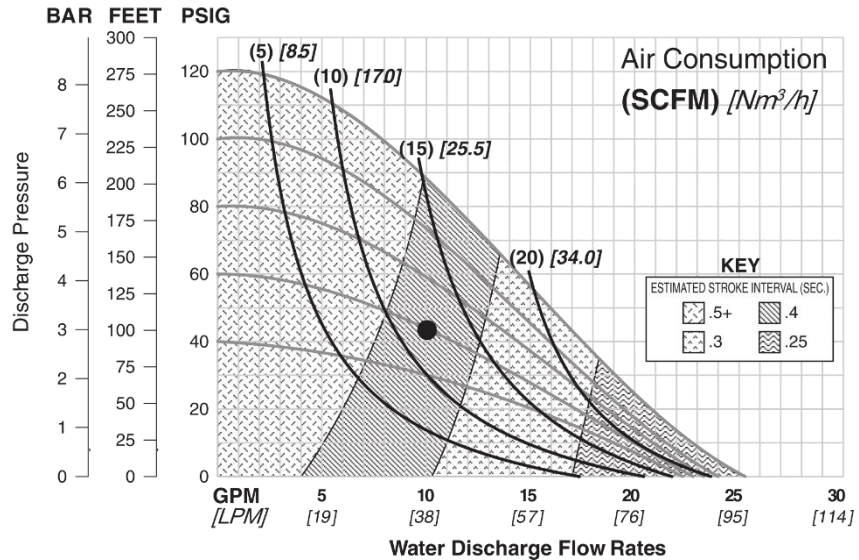

Flow rates indicated on chart were determined by pumping water.

For optimum life and performance, pumps should be specified so that daily operation parameters will fall in the center of the pump performance curve.

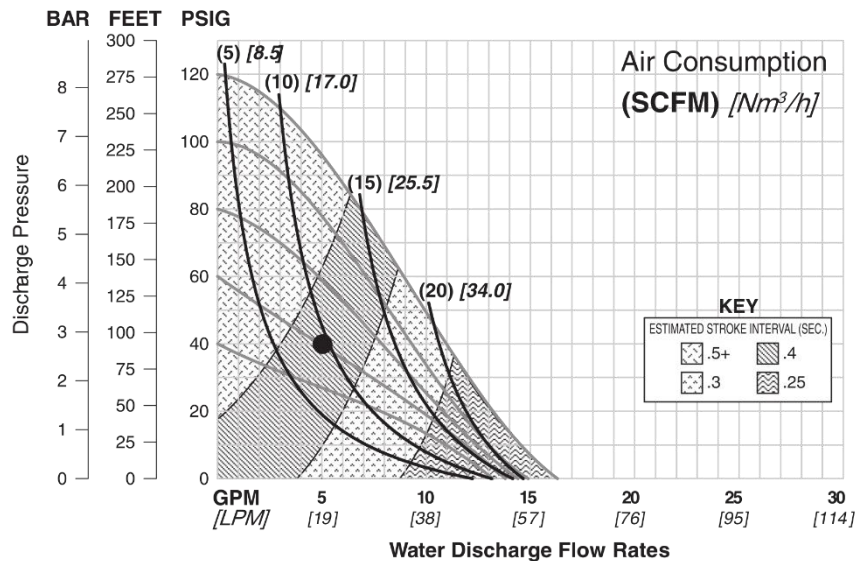

Flow rates indicated on chart were determined by pumping water.

For optimum life and performance, pumps should be specified so that daily operation parameters will fall in the center of the pump performance curve.

A2P PLASTIC RUBBER-FITTED

Height 356 mm (14.0")
 Width 297 mm (11.7")
 Depth 259 mm (10.2")
 Est. Ship Weight.....
 Polypropylene 8 kg (18 lbs)
 PVDF 10 kg (23 lbs)
 Air Inlet..... 6 mm (1/4")
 Inlet..... 25 mm (1")
 Outlet 25 mm (1")
 Suction Lift 6.2 m Dry (20.4')
 9.0 m Wet (29.5')
 Disp. Per Stroke¹ 0.12 l (0.030 gal.)
 Max. Flow Rate..... 136 lpm (36 gpm)
 Max. Size Solids..... 3.2 mm (1/8")

¹Displacement per stroke was calculated at 4.8 bar (70 psig) air inlet pressure against a 2 bar (30 psig) head pressure.

Example: To pump 75.7 lpm (20 gpm) against a discharge pressure head of 2.6 bar (37 psig) requires 4.1 bar (60 psig) and 40.8 Nm³/h (24 scfm) air consumption. (See dot on chart.)

Caution: Do not exceed 8.6 bar (125 psig) air supply pressure.

A2P PLASTIC PTFE-FITTED

Height 356 mm (14.0")
 Width 297 mm (11.7")
 Depth 259 mm (10.2")
 Est. Ship Weight.....
 Polypropylene 8 kg (18 lbs)
 PVDF 10 kg (23 lbs)
 Air Inlet..... 6 mm (1/4")
 Inlet..... 25 mm (1")
 Outlet 25 mm (1")
 Suction Lift 5.2 m Dry (17.0')
 9.0 m Wet (29.5')
 Disp. Per Stroke¹ 0.11 l (0.028 gal.)
 Max. Flow Rate..... 110 lpm (29 gpm)
 Max. Size Solids..... 3.2 mm (1/8")

¹Displacement per stroke was calculated at 4.8 bar (70 psig) air inlet pressure against a 2 bar (30 psig) head pressure.

Example: To pump 37.9 lpm (10 gpm) against a discharge pressure head of 3.2 bar (48 psig) requires 4.1 bar (60 psig) and 32.3 Nm³/h (19 scfm) air consumption. (See dot on chart.)

Caution: Do not exceed 8.6 bar (125 psig) air supply pressure.

PERFORMANCE

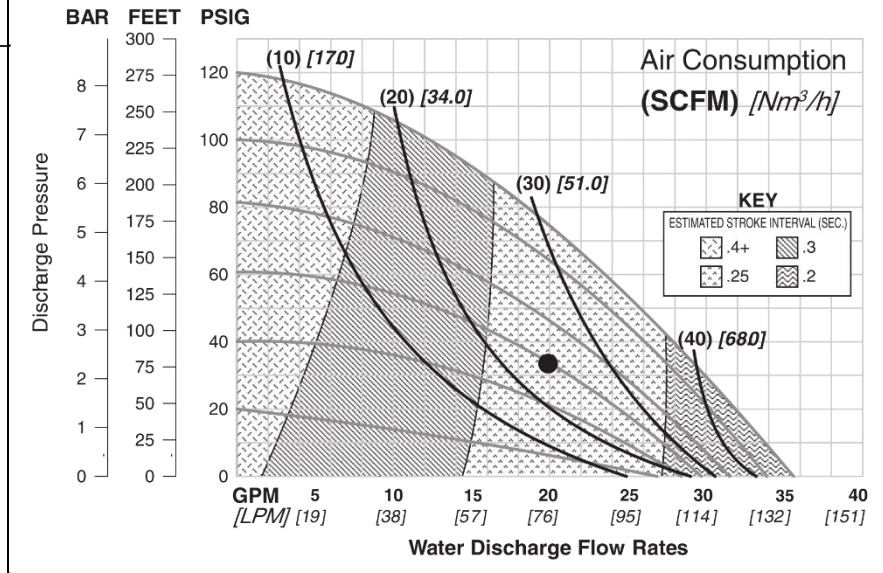

Flow rates indicated on chart were determined by pumping water.

For optimum life and performance, pumps should be specified so that daily operation parameters will fall in the center of the pump performance curve.

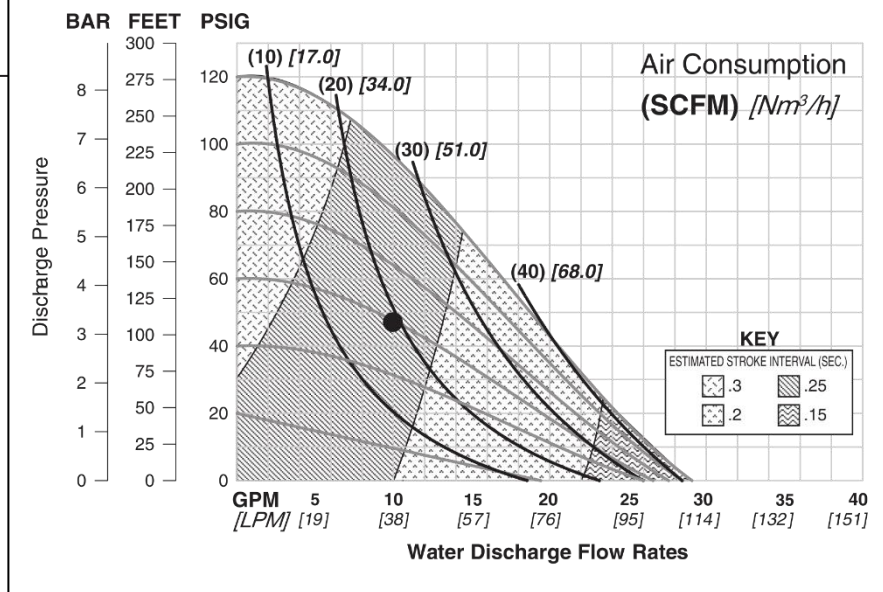

Flow rates indicated on chart were determined by pumping water.

For optimum life and performance, pumps should be specified so that daily operation parameters will fall in the center of the pump performance curve.

70/30 OPERATING CONDITIONS

A2T PLASTIC ACCU-FLO™

These curves demonstrate the flow created when the stroke rate is modified under static air and fluid pressure condition. This curve can be applied to different pressure conditions to estimate the change in flow due to stroke rate.

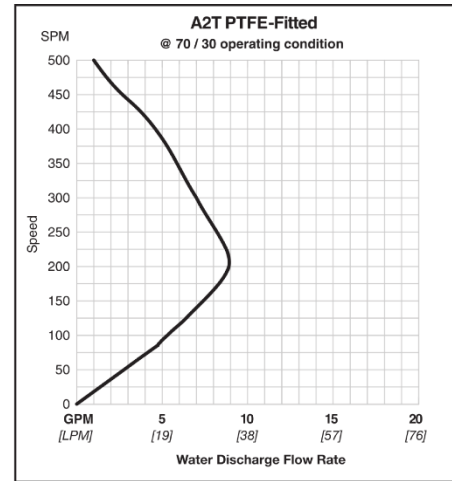
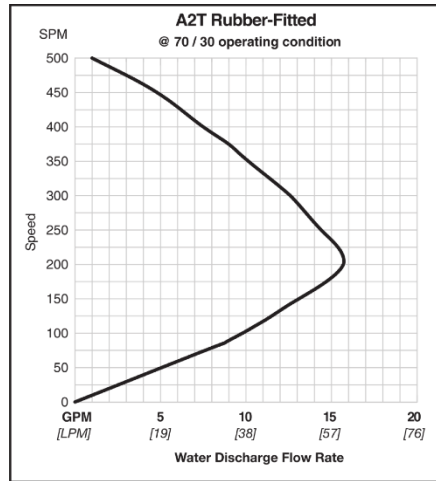

A2P PLASTIC ACCU-FLO™

These curves demonstrate the flow created when the stroke rate is modified under static air and fluid pressure condition. This curve can be applied to different pressure conditions to estimate the change in flow due to stroke rate.

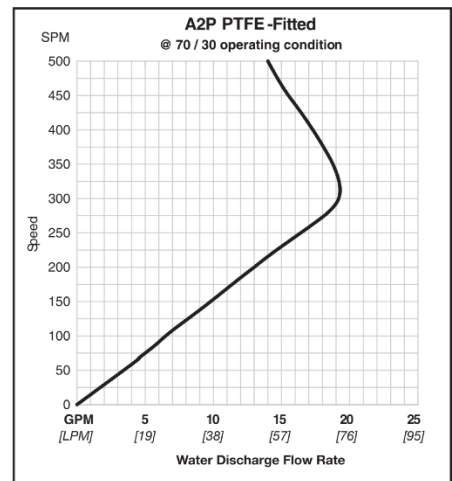
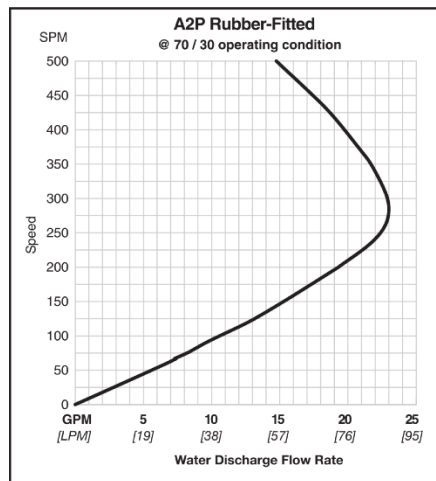

Section 6

Suggested Installation, Operation, Maintenance and Troubleshooting

All Wilden pumps are manufactured with a variety of materials for the air distribution system, liquid path and elastomers. This variety is offered to satisfy the temperature, chemical compatibility, abrasion and flex life requirements for most applications. Consult manual for available materials and temperature limitations for this pump model.

For Accu-Flo™ models only, all wiring used to operate the pump should be placed and connected according to all applicable electrical codes. It is important that the wiring be of adequate gauge to carry the current required to operate the pump. In addition, it is necessary that the electrical power supply be large enough to supply the current required to operate the pump. Wiring should be above ground level if possible (in case of fluid spill or leakage), and all wiring and connections which could become wet or damp should be made watertight.

The suction pipe used for installation should be sized equal to, or greater than, the pump liquid inlet connection. This will minimize pump cavitation and potential blockages of the pump inlet. The discharge piping should also be sized equal to, or greater than, the pump liquid discharge connection. If the pump is to be used in a self-priming application, be sure that all connections are airtight and that the suction lift is within the pump's ability. (Consult manual for suction lift information.)



NOTE: Materials of construction and elastomer materials have an effect on suction lift parameters.

Installation

Months of careful planning, study and selection efforts can result in unsatisfactory pump performance if installation details are left to chance. Premature failure and long term dissatisfaction can be avoided if reasonable care is exercised throughout the installation process.

Location

Noise, safety, and other logistical factors usually dictate that "utility" equipment be situated away from the production floor. Multiple installations with conflicting requirements can result in congested utility areas, leaving few choices for siting additional pumps.

Within the framework of these and other existing conditions, every pump should be located in such a way that four key factors are balanced against each other to maximum advantage:

- **Access:** First of all, the location should be accessible. If it is easy to reach the pump, maintenance personnel will have an easier time carrying out routine inspections and adjustments. Should major repairs become necessary, ease of access can play a key role in speeding the repair process and reducing total downtime.
- **Air Supply:** Every pump location should have an air line large enough to supply the volume of air necessary to achieve the desired pumping rate. (Consult manual for performance information.) The use of an air filter before the pump will ensure that the majority of pipeline contaminants will be eliminated. For best results, the pump should use an air filter, regulator system.

Sound levels are reduced below OSHA specifications using the standard Wilden muffler.

- **Elevation:** Selecting a site that is well within the pump's dynamic lift capability will assure that a loss-of-prime condition will be avoided. In addition, pump efficiency can be adversely effected if proper attention is not given to site location.

- **Piping:** Final determination of the pump site should not be made until the piping problems of each possible location have been evaluated. The impact of current and future installations should be considered ahead of time to make sure that inadvertent restrictions are not created for any remaining sites.

The best choice possible will be a site involving the shortest and straightest hook-up of suction and discharge piping. Unnecessary elbows, bends, and fittings should be avoided. Pipe sizes should be selected so as to keep friction losses within practical limits. All piping should be supported independently of the pump to avoid damage. In addition, the piping should be aligned so as to avoid placing stress on the pump fittings.

Flexible hose can be installed to aid absorbing the forces created by the natural reciprocating action of the pump. If the pump is to be bolted down to a solid location, a mounting pad placed between the pump and the foundation will assist in minimizing pump vibration. Flexible connections between the pump and rigid piping will also assist in minimizing pump vibration. If quick-closing valves are installed at any point in the discharge system, or if pulsation within a system becomes a problem, a Wilden Equalizer® surge dampener should be installed to protect the pump, piping and gauges from surges and water hammer. Installation of a tee at the discharge of the pump will allow the addition of an Equalizer to the system at a later date without requiring piping modifications. Installation of inlet and discharge isolation valves are also recommended to make service and repair easier.

Pumps in service with a positive suction head are most efficient when pressure is limited to 0.4-0.7 bar (7-10 psig). Premature diaphragm failure may occur if positive suction exceeds these recommended pressures.

A STRAINER SHOULD BE USED ON THE SUCTION LINE OF THE SYSTEM IF THERE IS A POSSIBILITY THAT SOLIDS ENTERING THE PUMP MAY EXCEED THE PUMP'S SOLIDS HANDLING CAPABILITIES.

PLEASE READ AND FOLLOW ALL CAUTIONS NOTED IN THIS MANUAL.

Pump should be thoroughly flushed before installing into process line.

Blow out air line for 10 to 20 seconds before attaching pump to clear all pipe line debris.

Suggested Installation, Operation, Maintenance and Troubleshooting

Operating Principles Behind Accu-Flo™ Pumps

When the solenoid is unpowered, one air chamber is pressurized with air, while the opposite chamber is exhausted. When electric power is applied, the solenoid shifts, and the pressurized air chamber is exhausted while the opposite chamber is pressurized. By alternately applying and removing power, the solenoid-operated pump runs like a standard Wilden pump.

The speed of the pump is controlled electrically. Since each stroke is controlled by an electrical signal, the pump is ideal for batching and other electrically controlled dispensing applications.

Although the speed of the pump is controlled electrically, the air pressure is important. Air pressure displaces the fluid, and if the pressure is insufficient to complete the physical stroke before an electronic impulse signals the pump to shift, the stroke will not be completed, and the displacement per stroke will be reduced. This does not harm the unit in any way, but it may cause inaccuracy when attempting to batch specific quantities with high precision if this effect is not taken into account.

There are three coil voltage options available. One coil allows for 24V DC operation. The second coil option allows for operation with either 12V DC or 24V AC at 60 Hz and the third coil option allows for 110V AC operation.

ELECTRICAL CONNECTIONS

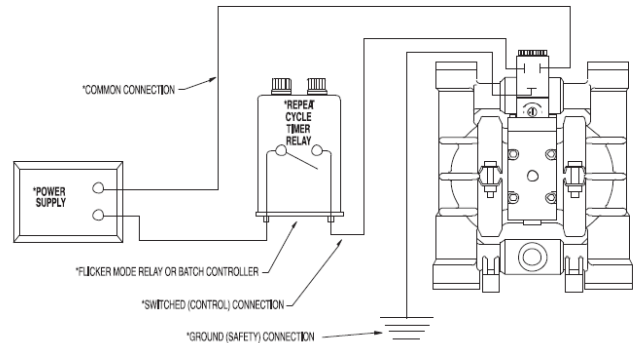

Plumbing Connections

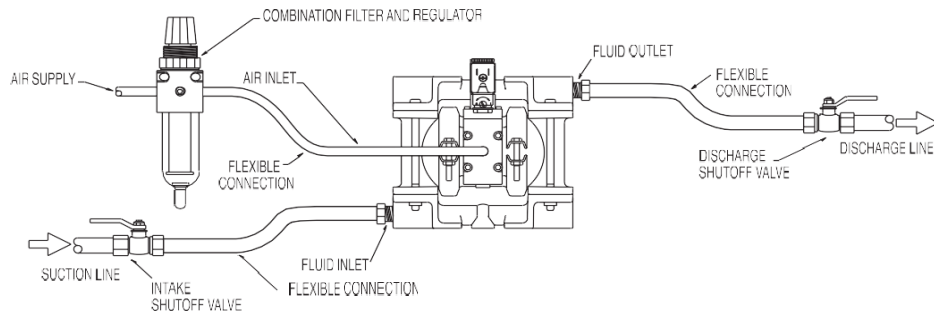

The speed of the pump is controlled electrically. Since each stroke is controlled by an electrical signal, the pump is ideal for batching and other electrically controlled dispensing applications. The pump will not shift reliably unless the minimum supply pressure is supplied. For the A2T the minimum supply pressure for reliable operation is 2.7 bar (40 psig). The solenoid operated pump is permanently lubricated during assembly, and requires no additional lubrication under normal operation. If the unit runs under extreme conditions (continuous operation at high speeds), it may be necessary to relubricate the center block with a Buna-N compatible NLGI Grade 2 grease every 50 million cycles. Continuous lubrication with a compatible oil is not harmful, and will provide longer seal life, but it may flush all grease out of the unit. A red button on the side of the air valve is a manual override; when actuated it will shift the valve as if an electric current had actuated the solenoid.



NOTE: In the event of a power failure, the shutoff valve should be closed, if the restarting of the pump is not desirable once power is regained.



NOTE: Wilden 6 mm (1/4") metal pumps come standard side ported with 2 NPT or BSP pipe plugs for side inlet and discharge porting. Center, top and bottom inlet and discharge porting are optional. Simply drill flat areas provided with a 7/16" drill bit for NPT or 11 mm drill bit for BSP and tap with NPT or BSP tap as appropriate.



NOTE: Wilden offers drum pump kits for the Metal P.025/A.025 pump (bung base and pick-up tube) for convenient drum pumping (P/N 50-9290-20/23/55).



NOTE: This pump can be mounted from the underside of a flat surface providing you more flexibility in tight areas/ systems.



CAUTION: Pump performance will be seriously hampered if pump is installed upside down

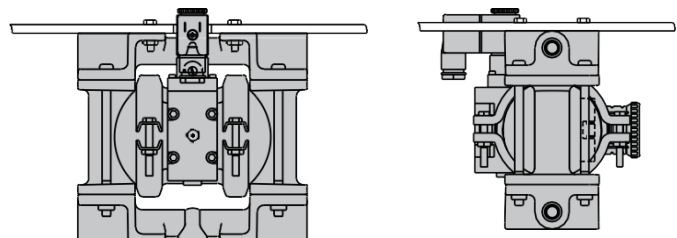

Suggested Installation, Operation, Maintenance and Troubleshooting

Operation

For best results, the pumps should use an air filter and a regulator. The use of an air filter before the pump inlet will ensure that the majority of pipeline contaminants will be eliminated. The solenoid operated pump is permanently lubricated during assembly, and requires no additional lubrication under normal operation. If the unit runs under extreme conditions (continuous operation at high speeds), it may be necessary to relubricate the center block with a Buna-N compatible NLGI Grade 2 grease every 50 million cycles. Continuous lubrication with a compatible oil is not harmful, and will provide longer seal life, but it may flush all grease out of the unit.

The pump will not shift reliably unless the minimum supply pressure is provided. For the A.025T the minimum supply pressure for reliable operation is 2.7 bar (40 psig).

A muffler can be installed to reduce the amount of noise generated by the pump. Use of the specified Wilden muffler will reduce noise levels below OSHA specifications.

Maintenance and Inspections

INSPECTIONS: Since each application is unique, maintenance schedules may be different for every pump. Frequency of use, line pressure, viscosity and abrasiveness of process fluid all effect the parts life of a Wilden pump. Periodic inspections have been found to offer the best means for preventing unscheduled pump downtime. Personnel familiar with the pump's construction and service should be informed of any abnormalities that are detected during operation. Internal maintenance is not recommended for Accu-Flo™ solenoid air valves. When worn or damaged, a new air valve body, coil or terminal connector must be purchased. Please consult section 9 for part numbers.

RECORDS: When service is required, a record should be made of all necessary repairs and replacements. Over a period of time, such records can become a valuable tool for predicting and preventing future maintenance problems and unscheduled downtime. In addition, accurate records make it possible to identify pumps that are poorly suited to their applications.

Suggested Installation, Operation, Maintenance and Troubleshooting

Troubleshooting

Pump will not run.

1. Check for pressurized air at the inlet.
2. Check air inlet and filter for debris.
3. Connect a test lamp to the two wires which run to pump and ensure that the lamp cycles on and off.
4. Make sure that the air valve manual override (small red knob on front of valve) is switched to the "0" position.
5. Check pilot pressure vent at the top of the operator/coil assembly to ensure that it is not clogged.
6. Check for a worn out air valve. If air continually blows out the exhaust in very large quantities, the air valve seals may be worn beyond their ability to function. In this case, the valve must be replaced.
7. NOTE: Before the valve is scrapped, it is possible that it may be saved by completely disassembling the valve, cleaning all components and relubricating the valve.

Pump runs but little or no fluid comes out.

1. Check that the discharge isolation valve is not closed.
2. Check that the electronic signal is slow enough that the pump is able to complete each physical stroke before it is signaled to change direction. The time required to complete the stroke is determined by a variety of factors which include fluid viscosity and head pressure.
3. Check for pump cavitation; slow pump speed down to match the thickness of the material being pumped.

4. Check for sticking ball check valves. If the material being pumped is not compatible with the pump elastomers, swelling may occur. Replace ball check valves and o-ring with the proper elastomers.
5. Check to make sure that all suction connections are air tight, and that the clamp bands are properly tightened.

Pump rattles.

1. See E9 Troubleshooting Guide.
2. Create false discharge head or suction lift.

Solenoid buzzes or solenoid burnout.

1. Incorrect voltage, faulty or dirty solenoid.

Solenoid valve fails to shift electrically but shifts with manual override.

1. Incorrect voltage, defective coil or wiring.

Solenoid valve fails to shift electrically or with manual override.

1. Inadequate air supply, contamination, inadequate or improper lubrication, mechanical binding in the valve.

Valve shifts but fails to return.

1. Solenoid buzzes or solenoid burnout. Incorrect voltage, faulty or dirty solenoid. Solenoid valve fails to shift electrically but shifts with manual override. Incorrect voltage, defective coil or wiring.

Excessive leaking from air valve vent.

1. Worn seals in air valve.

Section 7

Disassembly / Reassembly

Pump Disassembly

Tools Required:

- 1/2" Box Wrench
- 1/2" Socket
- 3/16" Allen Wrench
- 1/2" Socket Drive
- 2 – 1" Sockets or Adjustable Wrench
- Adjustable Wrench
- Vise equipped with soft jaws (such as plywood, plastic or other suitable material)



CAUTION: Before any maintenance or repair is attempted, the compressed air line to the pump should be disconnected and all air pressure allowed to bleed from the pump. Disconnect all intake, discharge, and air lines. Drain the pump by turning it upside down and allowing any fluid to flow into a suitable container. Be aware of any hazardous effects of contact with your process fluid.

The Wilden model A2 has a 25 mm (1") inlet and 25 mm (1") outlet and is designed for flows up to 136 lpm (36 gpm). The wetted path comes in both PVDF and polypropylene. The single-piece center section, consisting of center block and air chambers, is molded of polypropylene. All o-rings used in the pump are of a special material and shore hardness that should only be replaced with factory-supplied parts.

PLEASE read all directions before starting disassembly.



NOTE: The model used for these instructions incorporates PTFE diaphragms, balls, and seats. Models with rubber diaphragms, balls and seats are the same except where noted.



NOTE: Replace worn parts with genuine Wilden parts for reliable performance.



Step 1

Before starting disassembly, mark a line from each liquid chamber to its corresponding air chamber. This line will assist in proper alignment during reassembly.



Step 2

Using the 3/16" Allen Wrench, remove air valve bolts. Inspect air valve assembly for wear or damage.

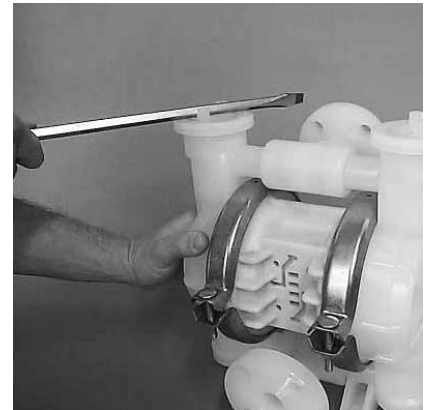

Step 3

Using a screwdriver or other long, slim object, loosen the top liquid retainers from the liquid chambers.

Disassembly / Reassembly



Step 4

Remove the top liquid retainer to expose the valve balls, valve seats and valve seat o-rings.



Step 5

Remove the top liquid retainer and retainer o-rings, discharge valve balls, seats and valve seat o-rings from the liquid chamber and inspect for nicks, gouges, chemical attack or abrasive wear. Replace worn parts with genuine Wilden parts for reliable performance.



Step 6

Using a 1/2" socket driver, loosen the bottom retainers.



Step 7

Remove the bottom liquid retainer and retainer o-rings, discharge valve balls, seats and valve seat o-rings from the liquid chamber and inspect for nicks, gouges, chemical attack or abrasive wear. Replace worn parts with genuine Wilden parts for reliable performance.

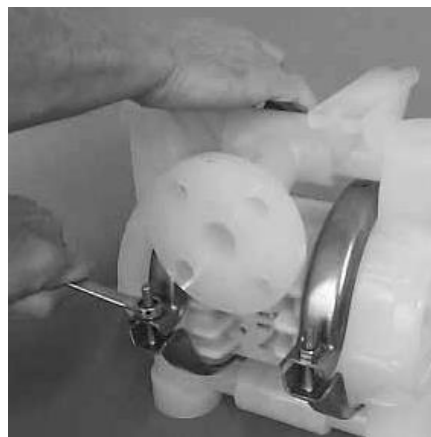

Step 8

With a 1/2" box wrench, loosen the large clamp bands that secure the liquid chambers to the center section.



Step 9

Rotate the clamp bands so that they can be removed.

Disassembly / Reassembly

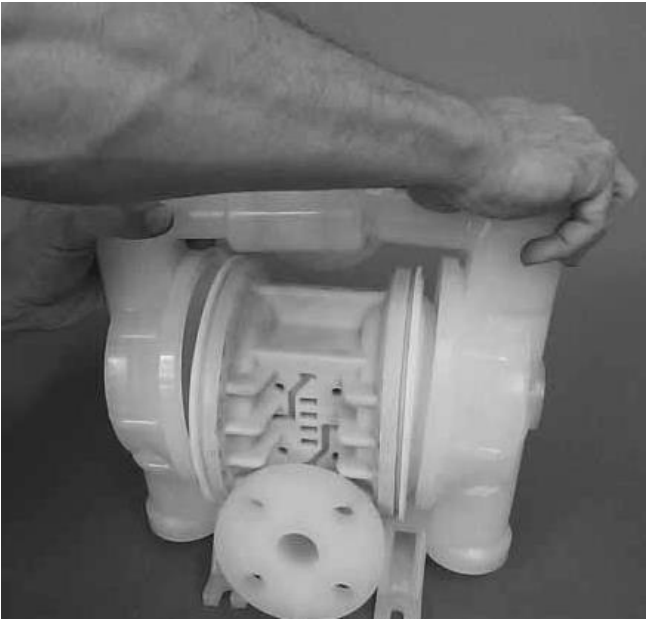

Step 10
After clamp bands are removed, pull liquid chambers apart.



Step 11
Remove tee section from liquid chamber and inspect o-rings for signs of wear. Replace worn parts with genuine Wilden parts for reliable performance.

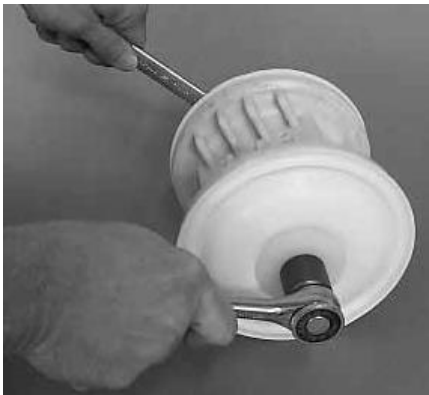

Step 12
Using two 1" sockets, remove diaphragm assembly from center section assembly.



Step 13
To remove the remaining diaphragm assembly from the shaft, secure shaft with soft jaws (a vise fitted with plywood or other suitable material) to ensure shaft is not nicked, scratched, or gouged. Using hands or an adjustable wrench, remove diaphragm assembly from shaft. Inspect all parts for wear and replace with genuine Wilden parts if necessary.

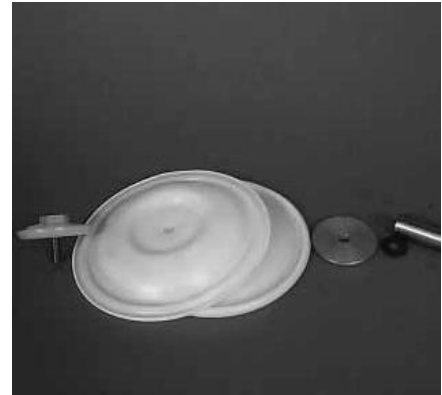

Step 14
Inspect diaphragms, outer and inner pistons and disc spring (not shown) for signs of wear. Replace with genuine Wilden parts if necessary.

Disassembly / Reassembly

Reassembly Hints & Tips

Upon performing applicable maintenance to the air distribution system, the pump can now be reassembled. Please refer to the disassembly instructions for photos and parts placement. To reassemble the pump, follow the disassembly instructions in reverse order. The air distribution system needs to be assembled first, then the diaphragms and finally the wetted path. Please find the applicable torque specifications on this page. The following tips will assist in the assembly process.

- Clean the inside of the center section shaft bushing to ensure no damage is done to new seals.
- Stainless bolts should be lubed to reduce the possibility of seizing during tightening.
- Be sure to tighten outer pistons simultaneously on PTFE-fitted pumps to ensure proper torque values.
- Apply two (2) drops of Loctite® 246 to the shaft internal threads before the diaphragm assembly.

MAXIMUM TORQUE SPECIFICATIONS

| Description of Part | Plastic Pumps |
|--------------------------------------|-----------------------|
| Solenoid Air Valve (Turbo-Flo™) | 2.3 N•m (20 in-lbs) |
| Solenoid Air Valve (Pro-Flo®) | 3.1 N•m (27 in-lbs) |
| Adapter Block Air Valve | 3.1 N•m (27 in-lbs) |
| Outer Piston—Rubber- and PTFE-fitted | 27.1 N•m (20 ft-lbs) |
| Top and Bottom Retainers | 14.1 N•m (125 in-lbs) |
| Large Clamp Band — Rubber-fitted | 10.7 N•m (95 in-lbs) |
| Large Clamp Band — PTFE-fitted | 14.1 N•m (125 in-lbs) |

Section 8

EXPLODED VIEW AND PARTS LISTING

A2T PLASTIC

EXPLODED VIEW

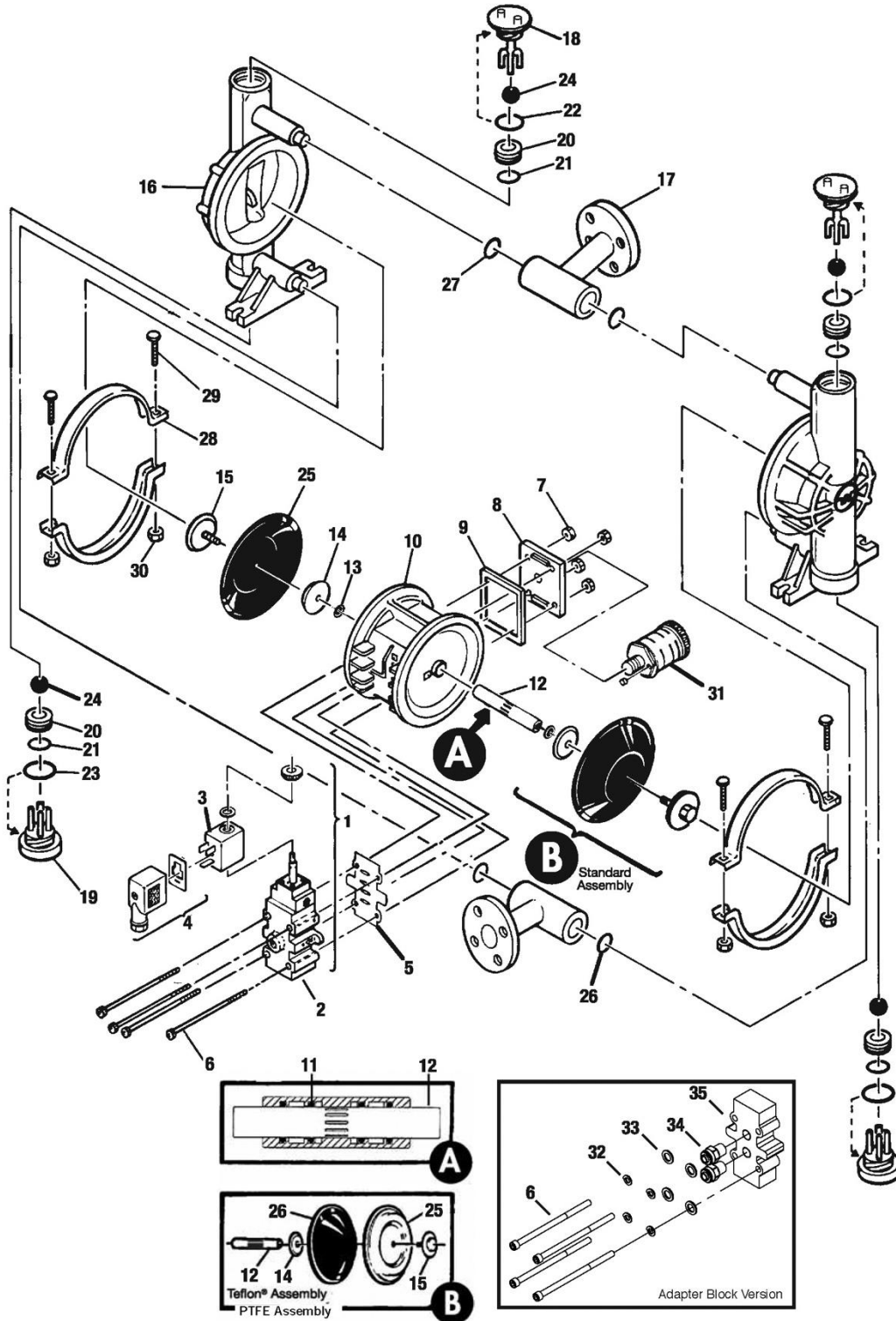

Exploded View and Parts List

| Item No. | Part Description | Qty. Per Pump | RUBBER-FITTED | | PTFE-FITTED | |
|----------|--------------------------------------|---------------|-----------------------|-----------------------|-----------------------|-----------------------|
| | | | A2T/PKPPA/0263 P/N | A2T/KKPPA/0263 P/N | A2T/PKPPA/0263 P/N | A2T/KKPPA/0263 P/N |
| 1 | Solenoid Valve Assembly | 1 | 02-2000-99-150 | 02-2000-99-150 | 02-2000-99-150 | 02-2000-99-150 |
| 2 | Main Valve Body | 1 | 02-2000-01-150 | 02-2000-01-150 | 02-2000-01-150 | 02-2000-01-150 |
| 3 | Coil | 1 | 00-2110-99-150 | 00-2110-99-150 | 00-2110-99-150 | 00-2110-99-150 |
| 4 | Terminal Connector ² | 1 | 00-2130-99 | 00-2130-99 | 00-2130-99 | 00-2130-99 |
| 5 | Air Valve Gasket — Buna-N | 1 | 02-2600-52 | 02-2600-52 | 02-2600-52 | 02-2600-52 |
| 6 | Air Valve Bolt 1/4"-20 x 6-1/4" | 4 | 02-6000-03 | 02-6000-03 | 02-6000-03 | 02-6000-03 |
| 7 | Air Valve Nut 1/4"-20 | 4 | 04-6400-03 | 04-6400-03 | 04-6400-03 | 04-6400-03 |
| 8 | Muffler Plate | 1 | 02-3180-20 | 02-3180-20 | 02-3180-20 | 02-3180-20 |
| 9 | Muffler Plate Gasket — Buna-N | 1 | 02-3500-52-500 | 02-3500-52-500 | 02-3500-52-500 | 02-3500-52-500 |
| 10 | Center Section | 1 | 02-3151-20-225 | 02-3151-20-225 | 02-3151-20-225 | 02-3151-20-225 |
| 11 | Center Section Glyd™ Ring | 4 | 02-3210-55-225 | 02-3210-55-225 | 02-3210-55-225 | 02-3210-55-225 |
| 12 | Shaft | 1 | 02-3820-03-07 | 02-3820-03-07 | 02-3820-03-07 | 02-3820-03-07 |
| 13 | Disc Spring | 2 | 02-6802-08 | 02-6802-08 | 02-6802-08 | 02-6802-08 |
| 14 | Inner Piston | 2 | 02-3750-01 | 02-3750-01 | 02-3750-01 | 02-3750-01 |
| 15 | Outer Piston | 2 | 02-4550-21-500 | 02-4550-21-500 | 02-4600-21-500 | 02-4600-21-500 |
| 16 | Liquid Chamber | 2 | 02-5001-20-400 | 02-5001-21-400 | 02-5001-20-400 | 02-5001-21-400 |
| 17 | Manifold Tee Section ¹ | 2 | 02-5160-20-400 | 02-5160-21-400 | 02-5160-20-400 | 02-5160-21-400 |
| 18 | Top Retainer | 2 | 02-5411-20-400 | 02-5411-21-400 | 02-5411-20-400 | 02-5411-21-400 |
| 19 | Bottom Retainer | 2 | 02-5420-20-400 | 02-5420-21-400 | 02-5420-20-400 | 02-5420-21-400 |
| 20 | Valve Seat | 4 | 02-1120-20-400 | 02-1120-21-400 | 02-1120-20-400 | 02-1120-21-400 |
| 21 | Valve Seat O-Ring* | 4 | * | * | 02-1200-60-400 | 02-1200-60-400 |
| 22 | Top Retainer O-Ring* | 2 | * | * | 02-1220-60 | 02-1220-60 |
| 23 | Bottom Retainer O-Ring | 2 | * | * | 02-1230-60 | 02-1230-60 |
| 24 | Valve Ball* | 4 | * | * | 02-1080-55 | 02-1080-55 |
| 25 | Diaphragm* | 2 | * | * | 02-1010-55 | 02-1010-55 |
| 26 | Back-up Diaphragm | 2 | | | 02-1060-51 | 02-1060-51 |
| 27 | Tee Section O-Ring* | 4 | * | * | 02-1300-60-400 | 02-1300-60-400 |
| 28 | Clamp Band Assembly | 2 | 02-7300-03-400 | 02-7300-03-400 | 02-7300-03-400 | 02-7300-03-400 |
| 29 | Clamp Band Bolt 5/16"-18 x 1-3/4" | 4 | 08-6050-03-500 | 08-6050-03-500 | 08-6050-03-500 | 08-6050-03-500 |
| 30 | Clamp Band Nut 5/16"-18 | 4 | 08-6400-03 | 08-6400-03 | 08-6400-03 | 08-6400-03 |
| 31 | Muffler | 1 | 02-3510-99 | 02-3510-99 | 02-3510-99 | 02-3510-99 |
| 32 | Lock Washer | 4 | 50-6760-03 | 50-6760-03 | 50-6760-03 | 50-6760-03 |
| 33 | Flat Washer | 4 | 01-6730-03 | 01-6730-03 | 01-6730-03 | 01-6730-03 |
| 34 | Air Fitting | 2 | 00-2170-20 | 00-2170-20 | 00-2170-20 | 00-2170-20 |
| 35 | Adapter Block | 1 | 02-2150-XX | 02-2150-XX | 02-2150-XX | 02-2150-XX |
| | Vent Plug (not shown) | 1 | 02-7020-17 | 02-7020-17 | 02-7020-17 | 02-7020-17 |
| | Expanded PTFE Gasket Kit (Not Shown) | 1 | | | 02-9500-99 | 02-9500-99 |

¹DIN Flange: Polypropylene = 02-5160-20-404, PVDF = 02-5160-21-404 ²Refer to corresponding elastomer chart in Section 10 for correct part number. **All boldface items are primary wear parts.**
³N/A for explosion proof. 0263 Pump Specialty Code = Solenoid-Operated, 24V DC

Solenoid-Operated Valve Assembly Options (consists of valve body, coil and connector)

| Pump Models Designating Specialty Code # | Part Number | Description |
|--|----------------|--|
| 151 | 02-2000-99-151 | 24V AC / 12V DC Valve Assembly |
| 153 | 02-2000-99-153 | 24V AC / 12V DC Valve Assembly (Nema 7) |
| 150 | 02-2000-99-150 | 24V DC Valve Assembly |
| 154 | 02-2000-99-154 | 24V DC Valve Assembly (Nema 7) |
| 157 | 02-2000-99-157 | International 24V DC Valve Assembly ¹ |
| 155 | 02-2000-99-155 | 110V AC Valve Assembly |
| 156 | 02-2000-99-156 | 110V AC Valve Assembly (Nema 7) |

Item 2 Main Valve Body Options

| Part Number | Description |
|----------------|--------------------------|
| 02-2000-01-150 | Main Valve Body |
| 02-2000-01-154 | Main Valve Body (Nema 7) |

Item 34 Adapter Block Options

| Part Number | Description |
|-------------|---------------|
| 01-2150-20 | Polypropylene |
| 01-2150-32 | UHMW PE |

Item 3 Coil Options

| Pump Models Designating Specialty Code # | Part Number | Description |
|--|----------------|--|
| 150 | 00-2110-99-150 | 24V DC Coil |
| 151 | 00-2110-99-151 | 24V AC Coil |
| 153 | 00-2110-99-153 | 24V AC, Nema 7 Coil |
| 154 | 00-2110-99-154 | 24V DC, Nema 7 Coil |
| 155 | 00-2110-99-155 | 110V AC Coil |
| 156 | 00-2110-99-156 | 110V AC Nema 7 Coil |
| 157 | 00-2110-99-157 | International 24V DC Coil ¹ |

¹Meets European standards and regulations; CENELEC/PTB File #EX-91.C.2027.

A25P PLASTIC

EXPLODED VIEW

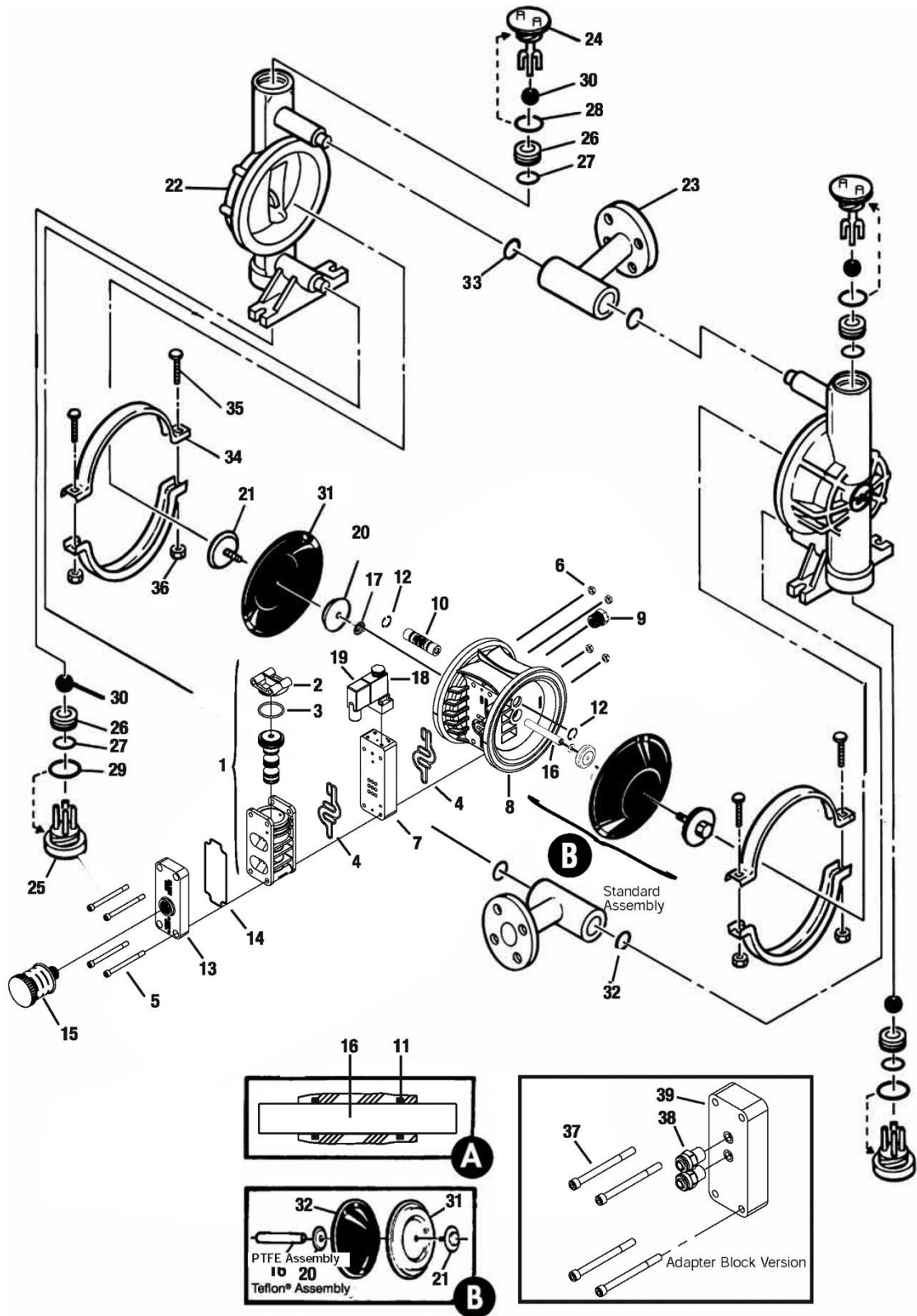

Exploded View and Parts List

| A2P ACCU-FLO™ | | | RUBBER-FITTED | | PTFE-FITTED | |
|---------------|--------------------------------------|---------------|--------------------|--------------------|--------------------|--------------------|
| Item No. | Part Description | Qty. Per Pump | A2P/PKPPP/0263 P/N | A2P/KKPPP/0263 P/N | A2P/PKPPP/0263 P/N | A2P/KKPPP/0263 P/N |
| 1 | Pro-Flo® Air Valve Assembly | 1 | 01-2010-20 | 01-2010-20 | 01-2010-20 | 01-2010-20 |
| 2 | End Cap | 1 | 01-2332-20 | 01-2332-20 | 01-2332-20 | 01-2332-20 |
| 3 | O-Ring, End Cap | 1 | 01-2395-52 | 01-2395-52 | 01-2395-52 | 01-2395-52 |
| 4 | Gasket, Air Valve | 2 | 01-2615-52 | 01-2615-52 | 01-2615-52 | 01-2615-52 |
| 5 | Screw, HSHC, Air Valve | 4 | 01-6000-03 | 01-6000-03 | 01-6000-03 | 01-6000-03 |
| 6 | Nut, Hex | 4 | 04-6400-03 | 04-6400-03 | 04-6400-03 | 04-6400-03 |
| 7 | Pro-Flo® Solenoid Spacer | 1 | 01-2160-20 | 01-2160-20 | 01-2160-20 | 01-2160-20 |
| 8 | Center Section Assembly | 1 | 02-3140-20 | 02-3140-20 | 02-3140-20 | 02-3140-20 |
| 9 | Bushing Reducer | 1 | 01-6950-20 | 01-6950-20 | 01-6950-20 | 01-6950-20 |
| 10 | Pilot Sleeve Plug | 1 | 02-2285-99 | 02-2285-99 | 02-2285-99 | 02-2285-99 |
| 11 | Glyd™ Ring II | 2 | 02-3210-55-225 | 02-3210-55-225 | 02-3210-55-225 | 02-3210-55-225 |
| 12 | Retaining Ring | 2 | 00-2650-03 | 00-2650-03 | 00-2650-03 | 00-2650-03 |
| 13 | Muffler Plate | 1 | 01-3181-20 | 01-3181-20 | 01-3181-20 | 01-3181-20 |
| 14 | Gasket, Muffler Plate | 1 | 01-3505-52 | 01-3505-52 | 01-3505-52 | 01-3505-52 |
| 15 | Muffler | 1 | 02-3510-99 | 02-3510-99 | 02-3510-99 | 02-3510-99 |
| 16 | Shaft Pro-Flo® | 1 | 02-3810-09 | 02-3810-09 | 02-3810-09 | 02-3810-09 |
| 17 | Disc Spring | 2 | 02-6802-08 | 02-6802-08 | 02-6802-08 | 02-6802-08 |
| 18 | Coil | 1 | 00-2110-99-150 | 00-2110-99-150 | 00-2110-99-150 | 00-2110-99-150 |
| 19 | Terminal Connector | 1 | 00-2130-99 | 00-2130-99 | 00-2130-99 | 00-2130-99 |
| 20 | Inner Piston | 2 | 02-3701-01 | 02-3701-01 | 02-3751-01 | 02-3751-01 |
| 21 | Outer Piston | 2 | 02-4550-21-500 | 02-4550-21-500 | 02-4600-21-500 | 02-4600-21-500 |
| 22 | Liquid Chamber | 2 | 02-5001-20-400 | 02-5001-20-400 | 02-5001-20-400 | 02-5001-21-400 |
| 23 | Manifold Tee Section ² | 2 | 02-5160-20-400 | 02-5160-21-400 | 02-5160-20-400 | 02-5160-21-400 |
| 24 | Top Retainer | 2 | 02-5411-20-400 | 02-5411-21-400 | 02-5411-20-400 | 02-5411-21-400 |
| 25 | Bottom Retainer | 2 | 02-5420-20-400 | 02-5420-21-400 | 02-5420-20-400 | 02-5420-21-400 |
| 26 | Valve Seat | 4 | 02-1120-20-400 | 02-1120-21-400 | 02-1120-20-400 | 02-1120-21-400 |
| 27 | Valve Seat O-Ring* | 4 | * | * | 02-1200-60-400 | 02-1200-60-400 |
| 28 | Top Retainer O-Ring* | 2 | * | * | 02-1220-60 | 02-1220-60 |
| 29 | Bottom Retainer O-Ring | 2 | * | * | 02-1230-60 | 02-1230-60 |
| 30 | Valve Ball* | 4 | * | * | 02-1080-55 | 02-1080-55 |
| 31 | Diaphragm* | 2 | * | * | 02-1010-55 | 02-1010-55 |
| 32 | Back-up Diaphragm | 2 | | | 02-1060-51 | 02-1060-51 |
| 33 | Tee Section O-Ring* | 4 | * | * | 02-1300-60-400 | 02-1300-60-400 |
| 34 | Clamp Band Assembly | 2 | 02-7300-03-400 | 02-7300-03-400 | 02-7300-03-400 | 02-7300-03-400 |
| 35 | Clamp Band Bolt 5/16"-18 x 1-3/4" | 4 | 08-6050-03-500 | 08-6050-03-500 | 08-6050-03-500 | 08-6050-03-500 |
| 36 | Clamp Band Nut 5/16"-18 | 4 | 08-6400-03 | 08-6400-03 | 08-6400-03 | 08-6400-03 |
| 37 | Air Valve Bolt | 4 | 04-6000-03 | 04-6000-03 | 04-6000-03 | 04-6000-03 |
| 38 | Fitting, Air Inlet | 2 | 00-2170-20 | 00-2170-20 | 00-2170-20 | 00-2170-20 |
| 39 | Adapter Block | 1 | 00-2155-20 | 00-2155-20 | 00-2155-20 | 00-2155-20 |
| | Expanded PTFE Gasket Kit (Not Shown) | 1 | | | 02-9500-99 | 02-9500-99 |

¹DIN Flange: Polypropylene = 02-5160-20-404, PVDF = 02-5160-21-404

0263 Pump Specialty Code = Solenoid-Operated, 24V DC

*Refer to corresponding elastomer chart in Section 10 for correct part number.

All boldface items are primary wear parts.

Solenoid-Operated Valve Assembly Options (consists of valve body, coil and connector)

| Pump Models Designating Specialty Code # | Part Number | Description |
|--|----------------|--|
| 151 | 02-2000-99-151 | 24V AC / 12V DC Valve Assembly |
| 153 | 02-2000-99-153 | 24V AC / 12V DC Valve Assembly (Nema 7) |
| 150 | 02-2000-99-150 | 24V DC Valve Assembly |
| 154 | 02-2000-99-154 | 24V DC Valve Assembly (Nema 7) |
| 157 | 02-2000-99-157 | International 24V DC Valve Assembly ¹ |
| 155 | 02-2000-99-155 | 110V AC Valve Assembly |
| 156 | 02-2000-99-156 | 110V AC Valve Assembly (Nema 7) |

Item 1 Main Valve Body Options

| Part Number | Description |
|----------------|--------------------------|
| 02-2000-01-150 | Main Valve Body |
| 02-2000-01-154 | Main Valve Body (Nema 7) |

Item 2 Coil Options

| Pump Models Designating Specialty Code # | Part Number | Description |
|--|----------------|--|
| 150 | 00-2110-99-150 | 24V DC Coil |
| 151 | 00-2110-99-151 | 24V AC Coil |
| 153 | 00-2110-99-153 | 24V AC, Nema 7 Coil |
| 154 | 00-2110-99-154 | 24V DC, Nema 7 Coil |
| 155 | 00-2110-99-155 | 110V AC Coil |
| 156 | 00-2110-99-156 | 110V AC Nema 7 Coil |
| 157 | 00-2110-99-157 | International 24V DC Coil ¹ |

¹Meets European standards and regulations; CENELEC/PTB File #EX-91.C.2027.

Section 9

Elastomer Options

A2 PUMPS

| Material | Color Code | Diaphragm P/N (2) | Valve Ball P/N (4) | Valve Seat* O-Ring P/N (4) | Tee Section O-Ring P/N (4) | Top Retainer O-Ring P/N (2) | Bottom Retainer O-Ring P/N (2) |
|------------------------|------------|-------------------|--------------------|----------------------------|----------------------------|-----------------------------|--------------------------------|
| Polyurethane | Natural | 02-1010-50 | 02-1080-50 | 02-1200-50-400 | 02-1300-50-400 | 02-1220-50 | 02-1230-50 |
| Buna-N | Red | 02-1010-52 | 02-1080-52 | 08-2390-52 | 04-2390-52 | 04-2390-52-700 | 02-1230-52 |
| PTFE Encapsulated FKM® | None | | | 02-1200-60-400 | 02-1300-60-400 | 02-1220-60 | 02-1230-60 |
| Neoprene | Green | 02-1010-51 | 02-1080-51 | | | | |
| FKM® | Silver | 02-1010-53 | 02-1080-53 | | | | |
| EPDM | Blue | 02-1010-54 | 02-1080-54 | | | | |
| PTFE | White | 02-1010-55 | 02-1080-55 | | | | |
| Saniflex™ | Off-White | 02-1010-56 | 02-1080-56 | | | | |
| Wil-Flex™ | Orange | 02-1010-58 | 02-1080-58 | 02-1200-58-400 | 02-1300-58-400 | 02-1220-58 | 02-1230-58 |
| Neoprene Backup | Black | 02-1060-511 | | | | | |

1. Saniflex™ back-up diaphragms, P/N 02-1060-56, are available upon request. Please consult your local distributor.

*NOTE: Rubber valve seats do not require an O-ring.

Electrical Information

NEMA 4 / UL / CSA

| Part Number | Voltage ±10% | | | Power (W) ±10% | Current (A) | | | Resistivity (Ω) |
|----------------|--------------|-------|-------|----------------|-------------|--------|---------|-----------------|
| | DC | AC | | | DC | AC | | |
| | | 60 Hz | 50 Hz | | | Inrush | Holding | |
| 00-2110-99-150 | 24 | 48 | 44 | 4.8 | .20 | .20 | .20 | 121 |
| 00-2110-99-151 | 12 | 24 | 22 | 4.8 | .40 | .40 | .40 | 32 |
| 00-2110-99-155 | 60 | 120 | 110 | 4.8 | .08 | .08 | .06 | 840 |

NEMA 7 / UL / CSA

| Part Number | Voltage ±10% | | | Power (W) ±10% | Current (A) | | | Resistivity (Ω) |
|----------------|--------------|-------|-------|----------------|-------------|--------|---------|-----------------|
| | DC | AC | | | DC | AC | | |
| | | 60 Hz | 50 Hz | | | Inrush | Holding | |
| 00-2110-99-153 | 12 | 24 | 22 | 7 | .60 | .55 | .32 | 19 |
| 00-2110-99-154 | 24 | 48 | 44 | 7 | .30 | .30 | .18 | 75 |
| 00-2110-99-156 | 60 | 120 | 110 | 7 | .12 | .13 | .06 | 475 |

INTERNATIONAL EXPLOSION PROOF / CENELEC / PTB FILE # EX-91.C.2027

| Part Number | DC Voltage ±10% | Power (W) ±10% | Current (A) | | Resistivity (Ω) |
|----------------|-----------------|----------------|-------------|---------|-----------------|
| | | | Inrush | Holding | |
| 00-2110-99-157 | 24 | 3.3 | .135 | .135 | 177 |

Notes

Notes

Notes

PSG
22069 Van Buren Street
Grand Terrace, CA 92313-5651 USA
P: +1 (909) 422-1730 • F: +1 (909) 783-3440
psgdover.com



Where Innovation Flows

PSG® reserves the right to modify the information and illustrations contained in this document without prior notice. This is a non-contractual document. 05- 2018