

# T8

# Engineering Operation & Maintenance

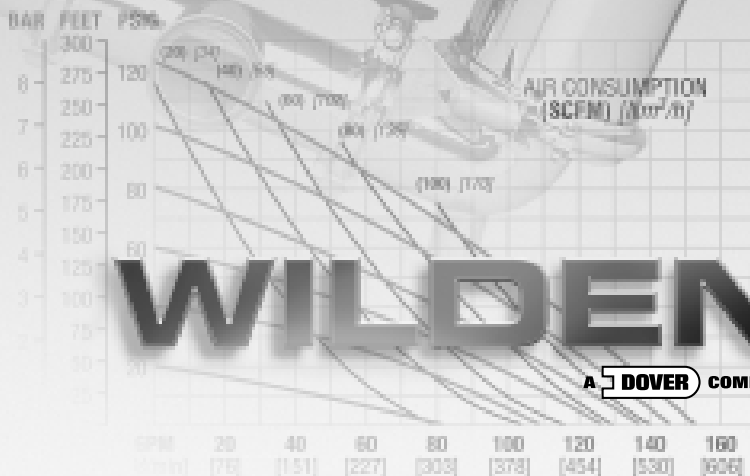
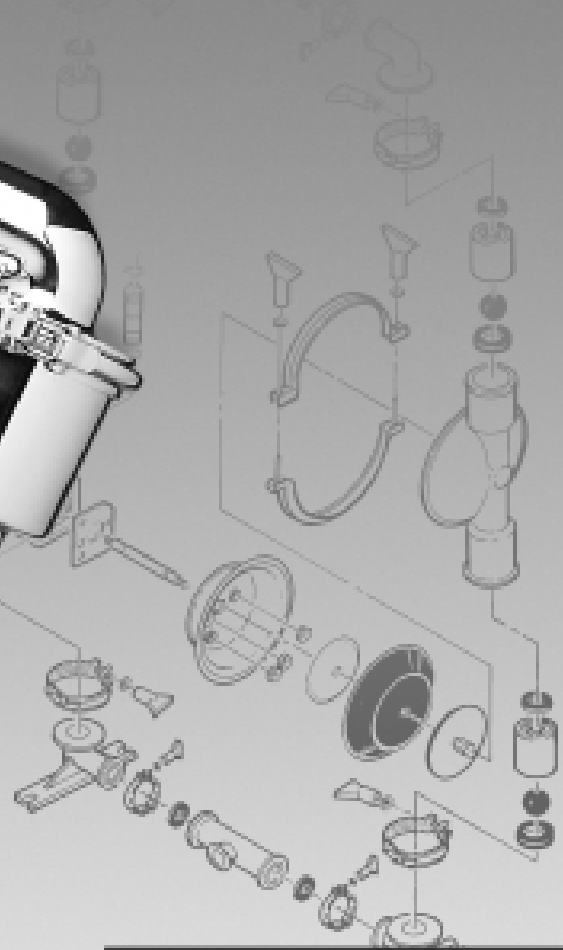
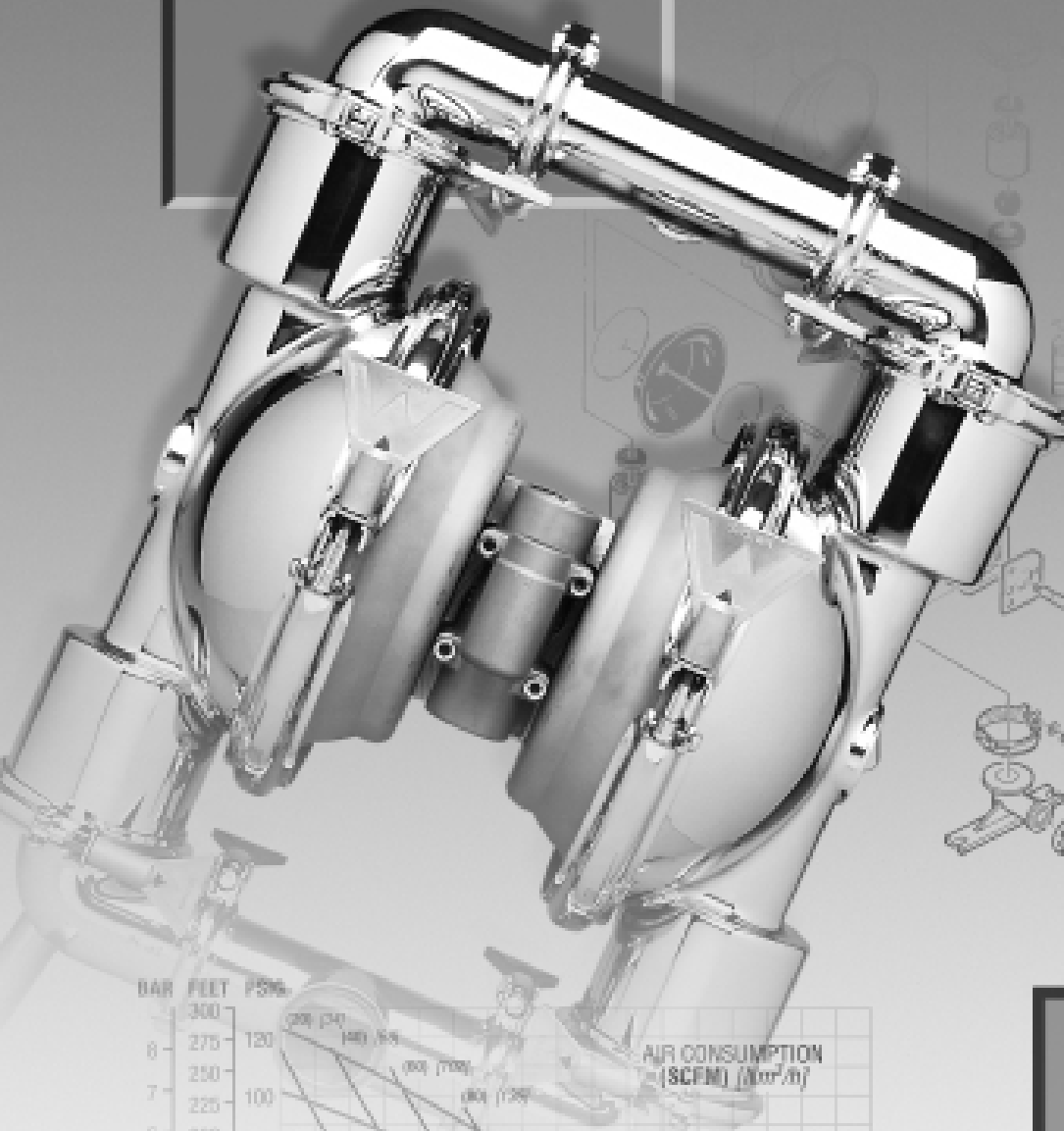

# WILDEN®

A DOVER COMPANY

**SANIFLO™**  
SANITARY PUMP TECHNOLOGY

## Metal Pumps

**SPECIFICATIONS AND PERFORMANCE**

**T8 SANIFLO<sup>USDA</sup>**

Height.....24" (609.6 cm)  
 Width.....18" (470.0 cm)  
 Depth.....14" (355.6 cm)  
 Ship Weight ..Stainless Steel 141 lbs. (64 kg)  
 Air Inlet.....¾" (1.91 cm)  
 Inlet.....2" (5.08 cm)  
 Outlet.....2" (5.08 cm)  
 Suction Lift.....9' Dry (2.74 m)  
 30' Wet (9.14 m)

Displacement per  
 Stroke ..... 0.56 gal. (2.08 l)  
 Max. Flow Rate.....153 gpm (579.16 lpm)  
 Max. Size Solids.....¾" (1.91 cm)  
 \*Displacement per stroke was calculated at 70 psig (4.8 Bar) air inlet pressure against a 30 psig (2 Bar) head pressure.

**Example:** To pump 80 gpm (303 lpm) against a discharge pressure head of 60 psig (4.1 Bar) requires 60 psig (4.1 Bar) and 60 scfm (102 Nm<sup>3</sup>/h) air consumption. (See dot on chart.)

**Caution:** Do not exceed 125 psig (8.6 Bar) air supply pressure.

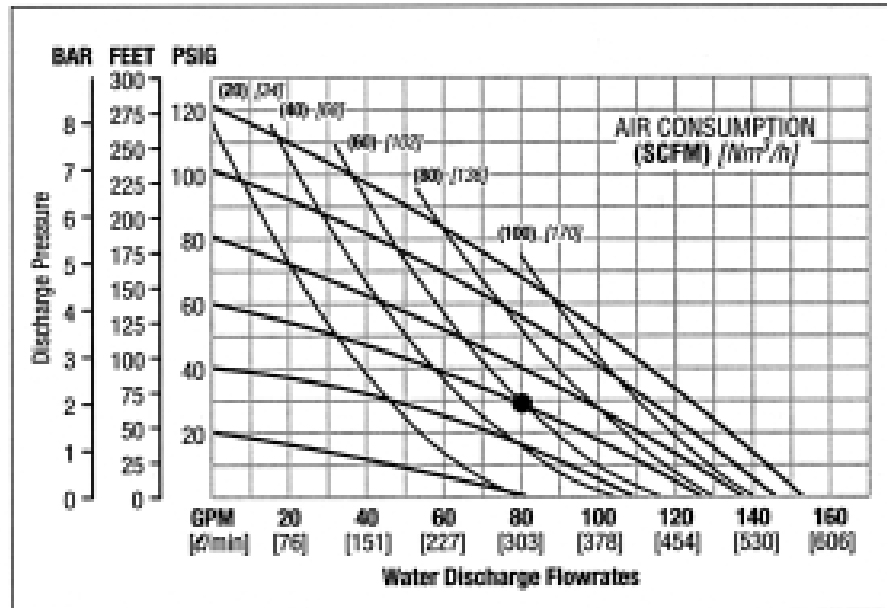

Flow rates indicated on chart were determined by pumping water.

For optimum life and performance, pumps should be specified so that daily operation parameters will fall in the center of the pump performance curve.

**Meter FT H<sub>2</sub>O T8 SaniFlo<sup>USDA</sup> Suction Lift Capability**

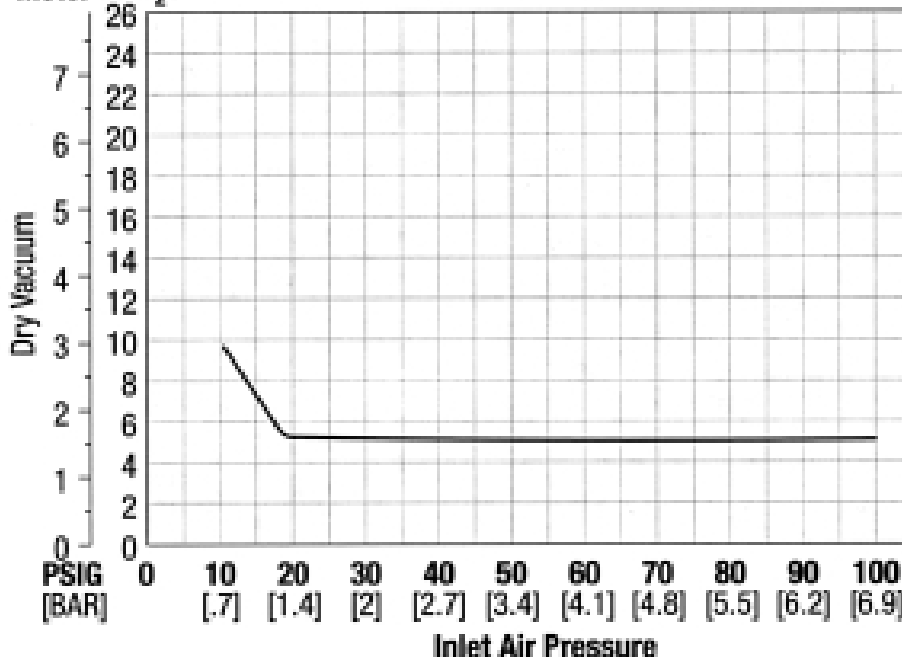

**WILDEN PUMP & ENGINEERING CO.**

22069 Van Buren Street  
 Grand Terrace, California 92313-5607  
 Phone (909) 422-1730  
 FAX (909) 783-3440

# DIMENSIONAL DRAWING – FOOTED MODEL

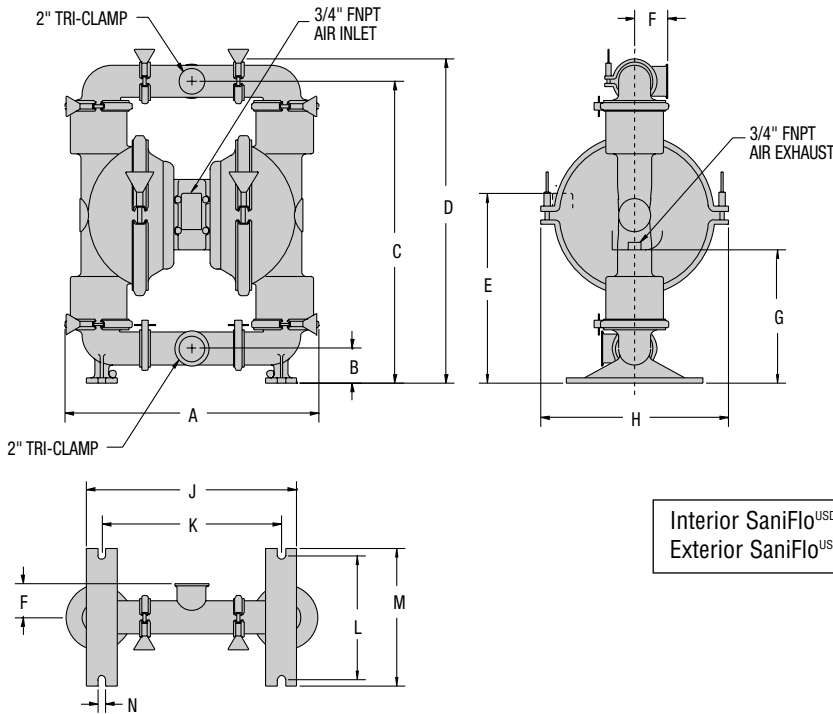

DIMENSIONS – T8 (SANIFLO <sup>USDA</sup> )		
ITEM	METRIC (mm)	STANDARD (inch)
A	470.0	18.50
B	63.5	2.50
C	562.0	2.12
D	609.6	24
E	352.4	14.87
F	61.9	2.43
G	244.5	9.62
H	355.6	14
J	388.9	15.31
K	333.4	13.12
L	228.6	9
M	254.0	10
N	14.3	.56

Stand-mounted model available.

Interior SaniFlo<sup>USDA</sup> finish is 150 Grit.  
Exterior SaniFlo<sup>USDA</sup> finish is 320 Grit.

**USDA ACCEPTED SANIFLO™  
ACCU-FLO™ MODEL AVAILABLE.**

## SECTION I

### WILDEN PUMP INSTALLATION/OPERATION INSTRUCTIONS

#### INSTALLATION INSTRUCTIONS

The Wilden SaniFlo<sup>USDA</sup> is a Wilden model T8 pump (2 inch) [5.08 cm] with all wetted parts of polished 316 Stainless Steel. Performance and operation of the SaniFlo<sup>USDA</sup> are essentially the same as other Wilden model T8 pumps of metal construction subject to temperature and chemical compatibility of the material being pump with 316 Stainless Steel and Saniflex™ TPE elastomers.

The T8 SaniFlo<sup>USDA</sup> comes standard with polished 316 Stainless Steel wetted parts and 316 Stainless Steel non-wetted parts. The T8 SaniFlo<sup>USDA</sup> should not be used for submersible applications unless both wetted and non-wetted portions are compatible with the material being pumped.

The T8 SaniFlo<sup>USDA</sup> has standard Tri-clamp\* two-inch pipe inlet and outlet ports. In permanent installations, the pumps should be attached to plant piping through flexible couplings on both the inlet and outlet ports to reduce pipe vibration due to the reciprocating nature of the pump. To further reduce vibration, a surge suppressor may be installed immediately adjacent to the discharge port.

Suction pipe size should be at least 2" (5.08 cm) diameter or even larger if highly viscous material is to be pumped. If suction hose is used, it must be of a non-collapsible, reinforced type as the T8 is capable of pulling a high vacuum. Discharge piping should be at least 2" (5.08 cm). It is critical, especially on the suction side of the pump, that all fittings and connections are airtight or a reduction or loss of pump suction capability will result.

THE T8 PUMP WILL PASS 3/4" (3.81 cm) DIAMETER SOLIDS. WHENEVER THE POSSIBILITY EXISTS THAT LARGER SOLID OBJECTS MAY BE SUCKED INTO THE PUMP, A STRAINER SHOULD BE USED ON THE SUCTION LINE.

The inlet to the air valve is 3/4" (1.91 cm) NPT. The compressed air line to the pump should be at least 3/4" (1.91 cm). The air line should be large enough to supply the volume of air necessary to achieve the desired pumping rate (see T8 pump performance curve). Use air pressure up to 125 psig (8.6 Bar) depending upon pumping requirements.

**CAUTION: Do not exceed 125 psig (8.6 Bar) air supply pressure.**

Pump discharge rate can be controlled by:

1. Limiting the volume and/or pressure of the air supply to the pump (preferred method). The use of a gate valve or needle valve installed at the air inlet to the pump is suggested for this purpose.
2. Throttling the pump discharge by installing a valve in the discharge line of the pump when the need to control the pump from a remote location exists. When the pump discharge pressure equals or exceeds the air supply pressure, the pump will stall out; no bypass or pressure relief valve is needed and pump damage will not occur.

Sound level can be reduced below 90 dba by attaching our optional muffler at pump air exhaust port.

**Temperature Limits:** 220°F (93°C) on Saniflex™ TPE food grade elastomers.

**CAUTION: Maximum temperature limits are based upon mechanical and corrosive factors. Certain chemicals will significantly reduce maximum safe operating temperatures. Consult Chemical Resistance Guide (RBG E4) for chemical compatibility and temperature limits.**

\*Tri-clamp is a registered trademark of the Ladish Corp.

**WARNING: PREVENTION OF STATIC SPARKING — IF STATIC SPARKING OCCURS, FIRE OR EXPLOSION COULD RESULT. PUMP, VALVES, AND CONTAINERS MUST BE GROUNDED WHEN HANDLING FLAMMABLE FLUIDS AND WHEREVER DISCHARGE OF STATIC ELECTRICITY IS A HAZARD.**

## OPERATING INSTRUCTIONS

**A.** The model T8 comes with a built-in oil reservoir. This should be kept filled with a lubricant such as mineral oil, or a synthetic such as CP-4600-32-F or CP-4608-32-F, product of CPI Engineers of Midland, Michigan. If the pump is placed in a permanent installation, the use of an air line oil lubricator is suggested. No alterations should be made to the pump.

**B.** Make sure air line to pump is free from dirt or other foreign matter. The air valve screen P/N 09-2500-03 (see air valve diagram) will generally collect any particles too large to pass through the pump's air system. If pump performance drops off, check this screen for clogging.

**C.** Turn on air supply to pump. **CAUTION:** Make sure air supply pressure to pump does not exceed 125 psig. If it does, a pressure regulator should be installed and set at a maximum of 125 psig.

**D.** Pumping volume (gpm) can be set by counting the number of strokes per minute. The T8 pumps approximately .77 gallons per stroke. A stroke is 1/2 cycle or one air exhaust.

When the pump is used for moving thick materials, check stroke rate to determine that pump is not operating at a faster rate than material is capable of flowing, or cavitation will occur. If pump is operating at a speed too fast for available flow, reduce the volume of air to the pump until stroke rate approximates discharge volume.

**E.** Always flush pump after use if material being pumped will pack or solidify. The pump can be turned upside down and all liquid will drain out.

**CAUTION: WEAR SAFETY GLASSES. IF DIAPHRAGM FAILURE OCCURS, MATERIAL BEING PUMPED MAY BE FORCED OUT AIR EXHAUST.**

## TROUBLESHOOTING

### Pump will not run or runs slowly:

1. Check air inlet screen for dirt.
2. Check for sticking air valve, flush air valve in solvent.
3. Check for worn out air valve. If piston face in air valve is shiny instead of dull, air valve is probably worn beyond working tolerances and must be rebuilt by Wilden or replaced.
4. Check center block Glyd™ rings. If worn excessively they will not seal and air will simply flow through pump and out air exhaust. Use only Wilden Glyd™ rings as they are of special construction.

### Product runs but little or no product flows:

1. Check for pump cavitation; slow pump speed down to match thickness of material being pumped.
2. Check for sticking valve balls. If material being pumped is not compatible with pump elastomers, swelling may occur; replace balls and seats with proper elastomers.
3. Check to make sure all suction connections are airtight, especially clamp bands around intake manifold.

### Air bubbles in pump discharge:

1. Check for ruptured diaphragm.
2. Check tightness of clamp bands, especially at intake manifold.

### Product comes out air exhaust:

1. Check for diaphragm rupture.
2. Check tightness of piston plates to shaft.
3. Ensure piston O-ring is in place, if required on model involved.

### Pump rattles:

1. See RBG E9 Troubleshooting Guide.
2. Create false discharge head or suction lift.

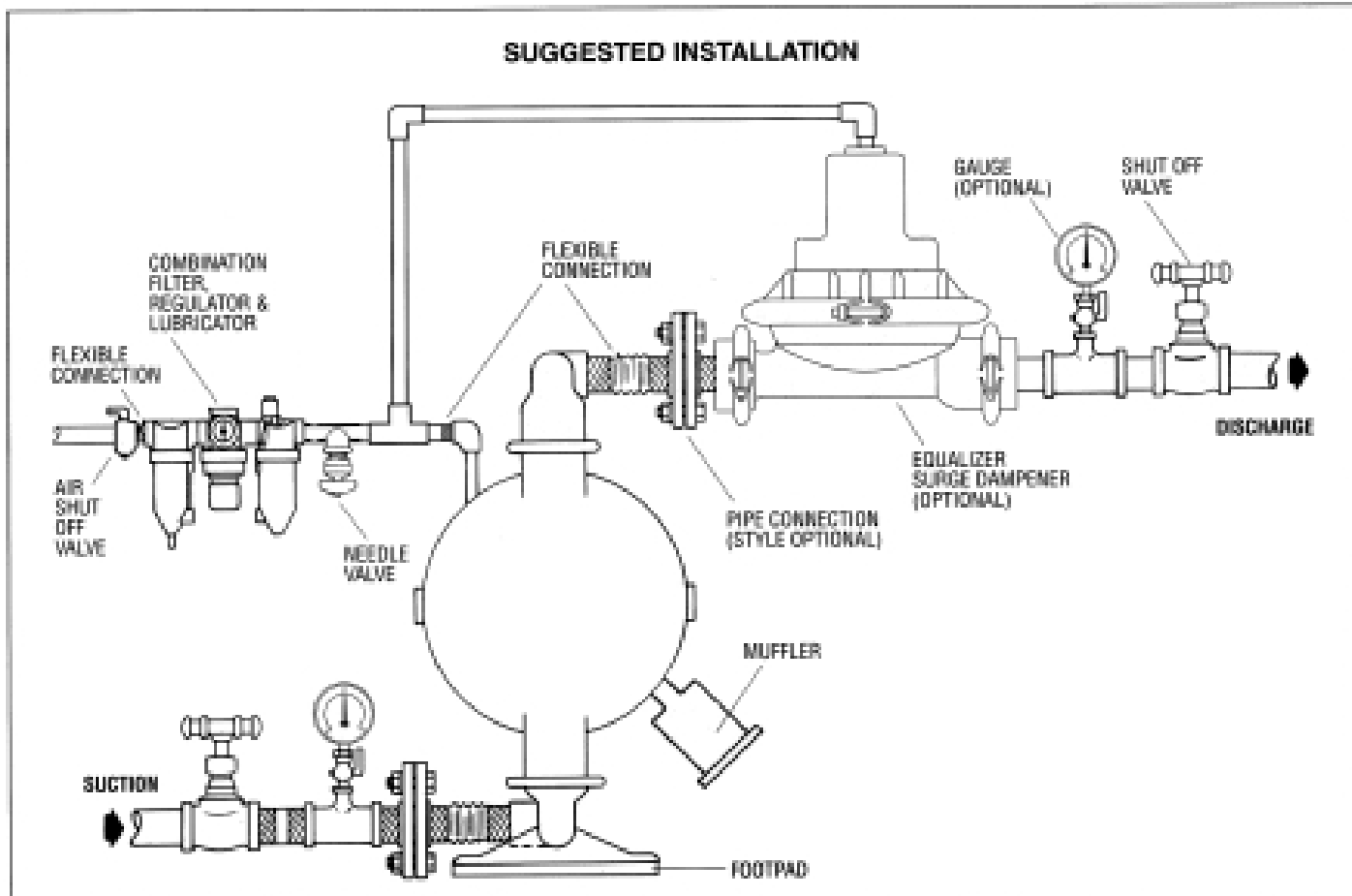

## SECTION II

# DIRECTIONS FOR DISASSEMBLY/ REASSEMBLY OF PUMP

**CAUTION:** Before any maintenance or repair is attempted, the compressed air line to the pump should be disconnected and all air pressure allowed to bleed from pump. Disconnect all intake, discharge, and air lines. Drain the pump by turning it upside down and allowing any fluid to flow into a suitable container.

The Wilden SaniFlo<sup>SM</sup> is a USDA accepted sanitary pump for meat and poultry applications. It is designed for quick take-down and reassembly at frequent intervals. It is fastened together with clamp bands secured by wing-type nuts on the clamp bands. Square-cornered O-rings are used for gaskets between metal surfaces. Generally, no tools are required to disassemble the wetted parts of the pump. A vise with soft jaws and an adjustable wrench are required to remove the diaphragms, and a 3/8-inch Allen wrench is needed to remove the air valve. During reassembly, the square O-rings should be inspected for deterioration or damage. These O-rings should function satisfactorily through many takedowns, but must be replaced at any sign of failure.

**NOTE:** Before starting disassembly, mark a line from each liquid chamber to its corresponding air chamber. This line will assist in proper alignment during reassembly.

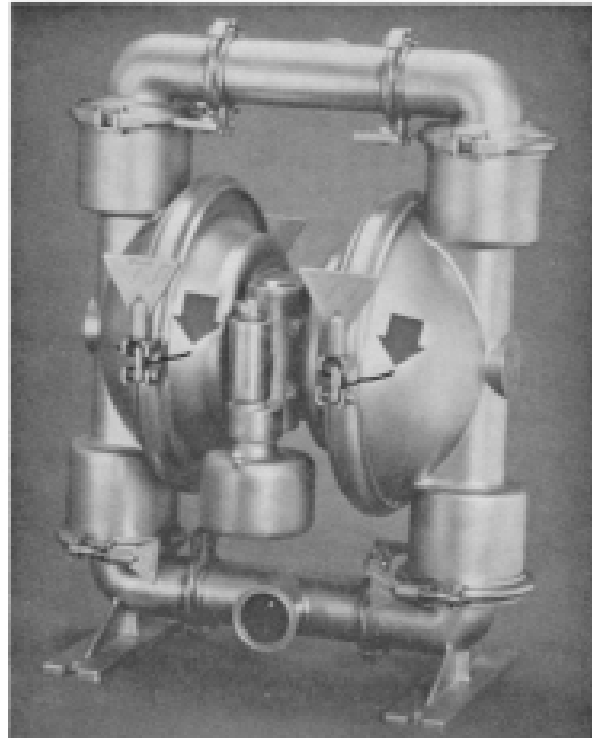

## DISASSEMBLY

### Step 1

Start by removing the two clamp bands that fasten the discharge manifold to the main body of the pump.

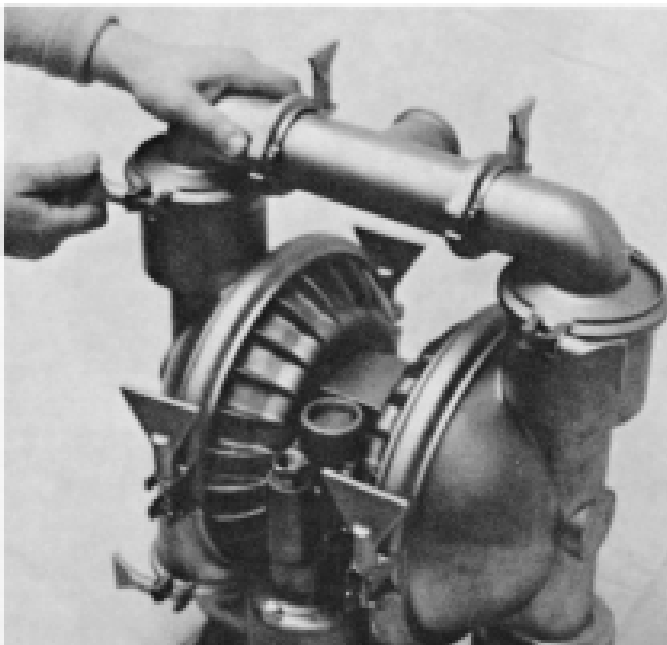

Figure 1A

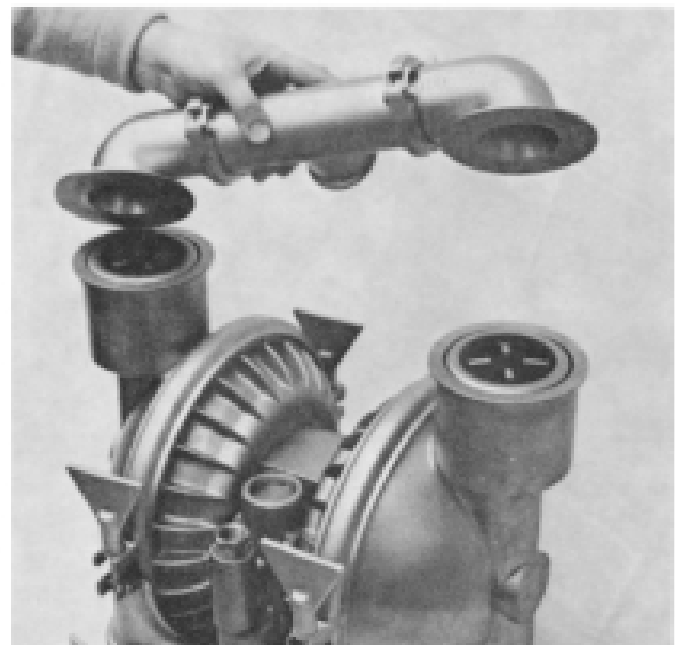

Figure 1B

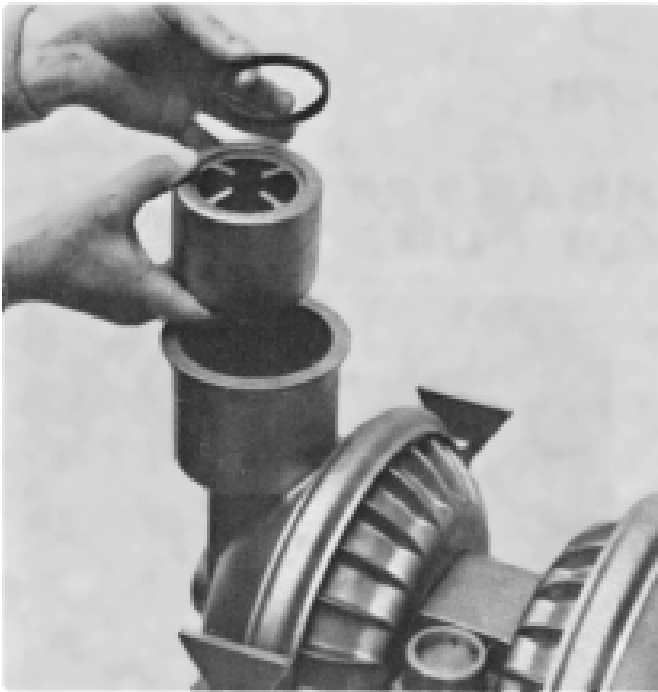

Figure 2A



Figure 2B

### Step 2

The square O-ring (P/N 08-1350-56-72) is now exposed for inspection. Remove the O-ring and check for swelling or damage. If there is damage, the O-ring must be replaced. Next remove the valve ball cage (P/N 08-5360-10-72), valve ball, and seat. Inspect these parts for damage or excessive wear.

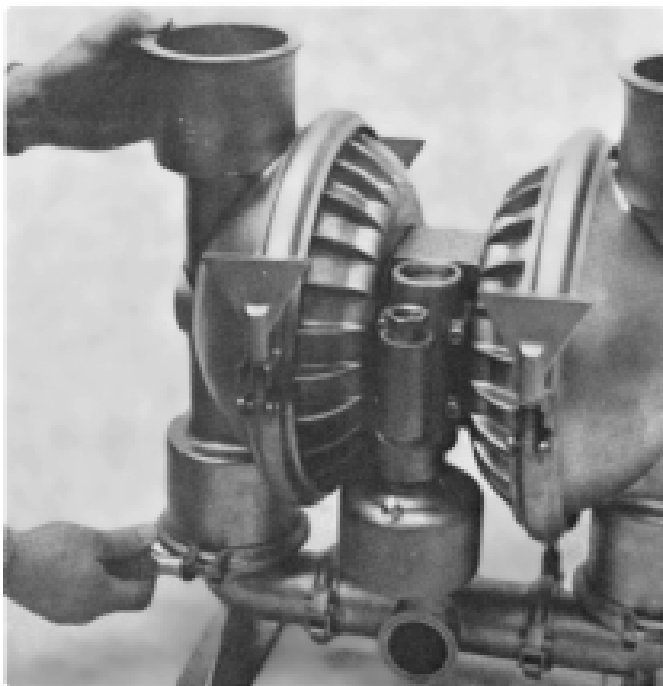

Figure 3A

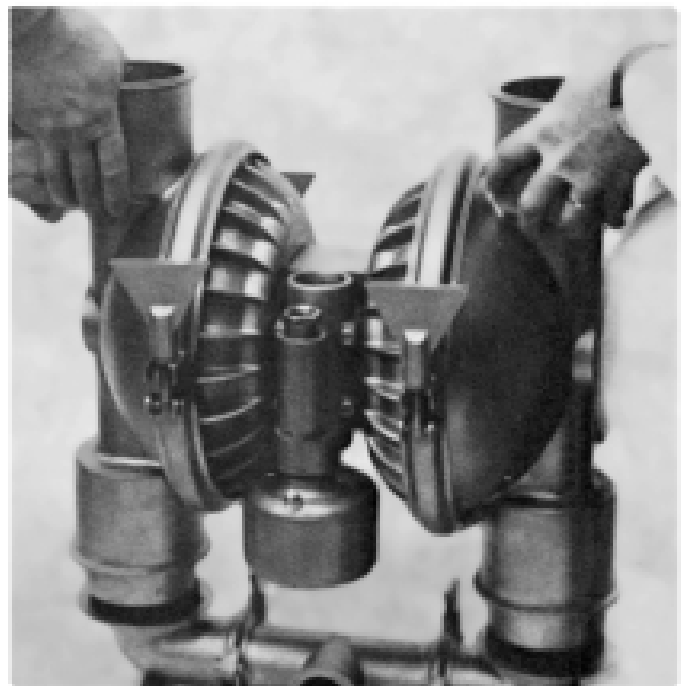

Figure 3B

### Step 3

Remove the two clamp bands that hold the inlet manifold to the main body of the pump. Lift the main body of the pump from the inlet manifold and set it to one side. The inlet valve ball cages, ball valves, seats, and O-rings are now available for examination.

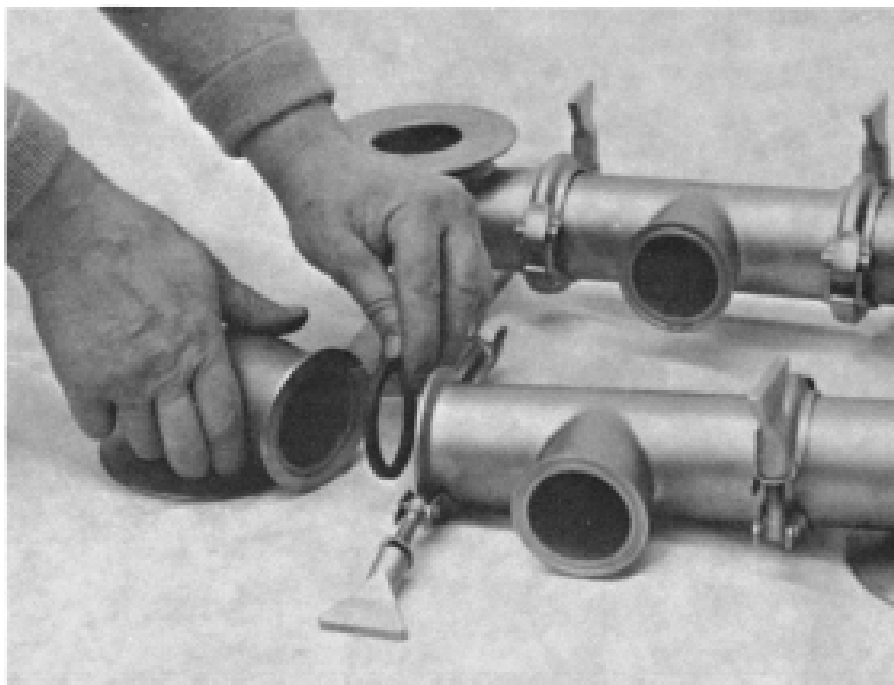

Figure 4A

**Step 4**

Both inlet and discharge manifolds can now be disassembled by removing their clamp bands. Make sure the square O-rings are not damaged or swollen. These O-rings form the seal between the manifold parts and will not perform their function if damaged.

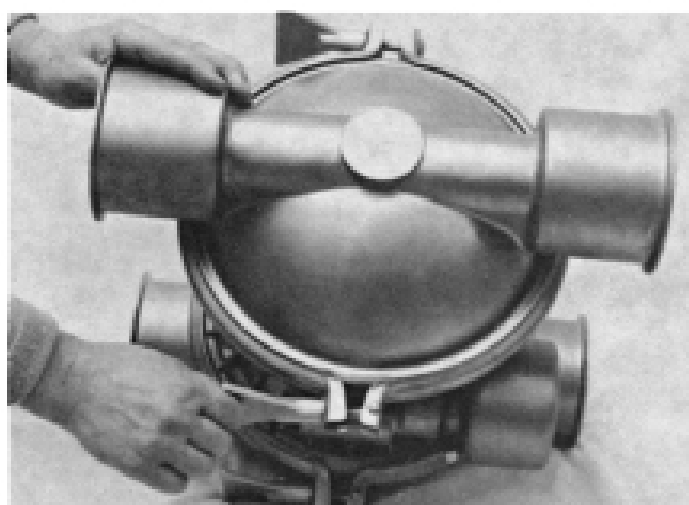

Figure 5A



Figure 5C

**Step 5**

Remove only one liquid chamber (P/N 08-5000-10-72) from the center section. This will expose the diaphragm and its piston plate. By grasping the outer edges of the diaphragm and turning counterclockwise, the diaphragm and piston plate can be removed by unscrewing them from the connecting shaft. The opposite diaphragm will be held tight by the opposite liquid chamber. **NOTE:** The shaft may unscrew from the opposite diaphragm. Flats are provided on the piston plate for a wrench if necessary. Now remove the opposite liquid chamber. The second diaphragm is now available for inspection and cleaning. At this point of disassembly, all food contact areas of the pump are available for inspection and cleaning.

If inspection, and/or servicing, of the non-wetted air section is necessary, please see Section II.

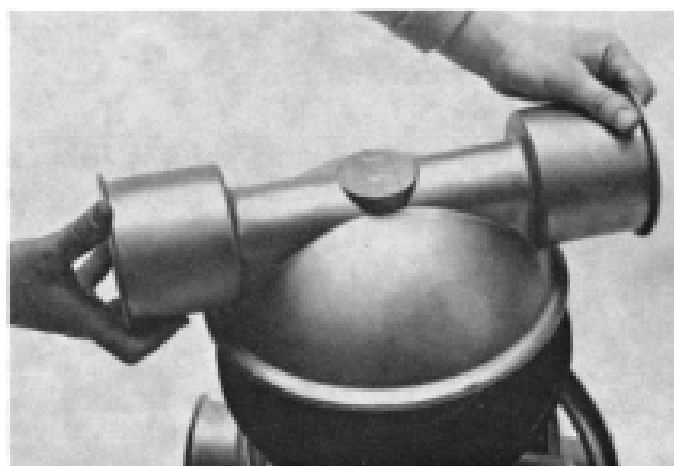

Figure 5B

## ASSEMBLY:

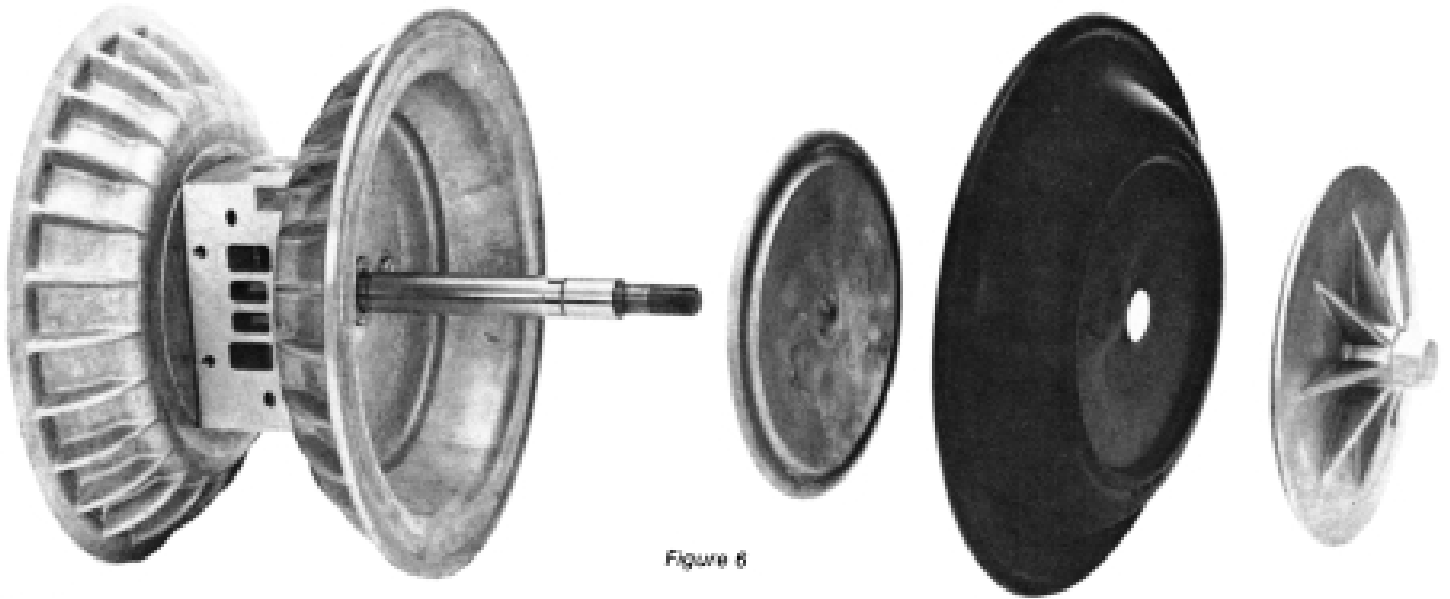

Figure 6

### Step 1

First install diaphragm and inner and outer piston plates on shaft. Observe this side out, marking on the convex side of the diaphragm. Hand tighten only at this time the outer piston to the shaft. Lubricate the center block bushing with a non-synthetic, non-detergent oil (10 wt). Insert the shaft through the bushing until the outer bead of the diaphragm just touches the circumferential groove of the air chamber.

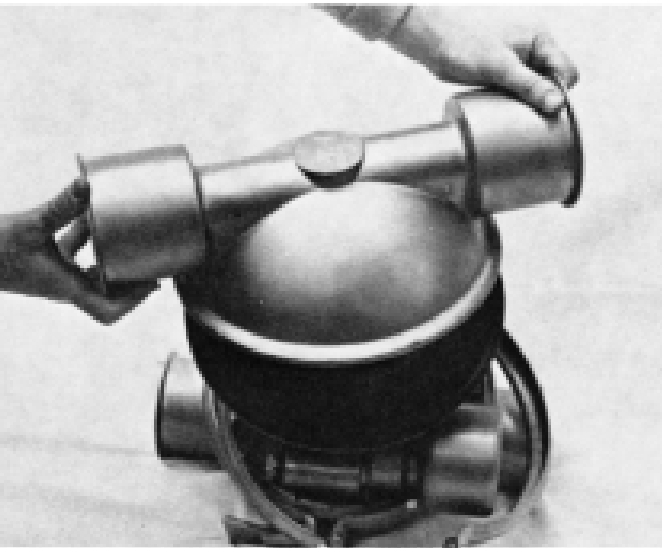

Figure 7A

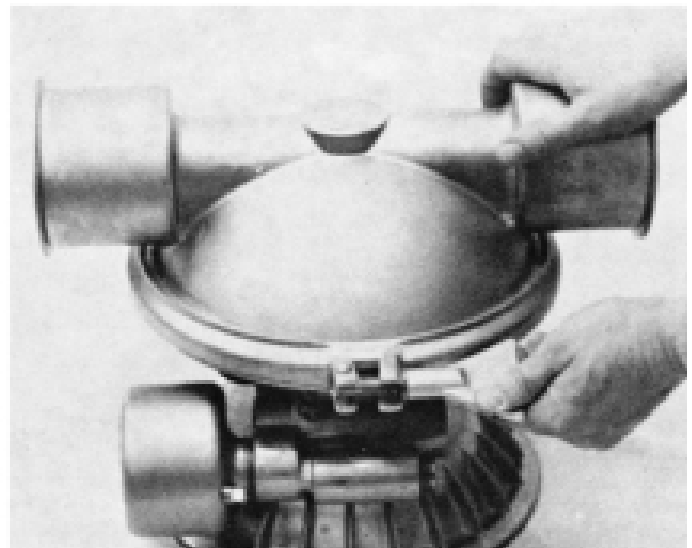

Figure 7B

### Step 2

Install the water chamber over the diaphragm using the alignment marks that were made during disassembly as an alignment guide. **NOTE:** Be sure to observe the direction of flow marking on the liquid chamber. Direction of flow through the pump is bottom to top. Install clamp band and tighten wing nut.





Figure 8

**Step 3**

Install opposite diaphragm on shaft observing proper sequence (refer to Figure 6), grasp the diaphragm by its edges, and pull it out toward you. Next, hold the diaphragm as shown above and tighten on shaft. This will tighten both diaphragms. An adjustable wrench can be used on the diaphragm piston plate flats, but generally, tightening by hand is sufficient. Set the liquid chamber on the diaphragm, observing the previously made alignment marks, and install the clamp band.

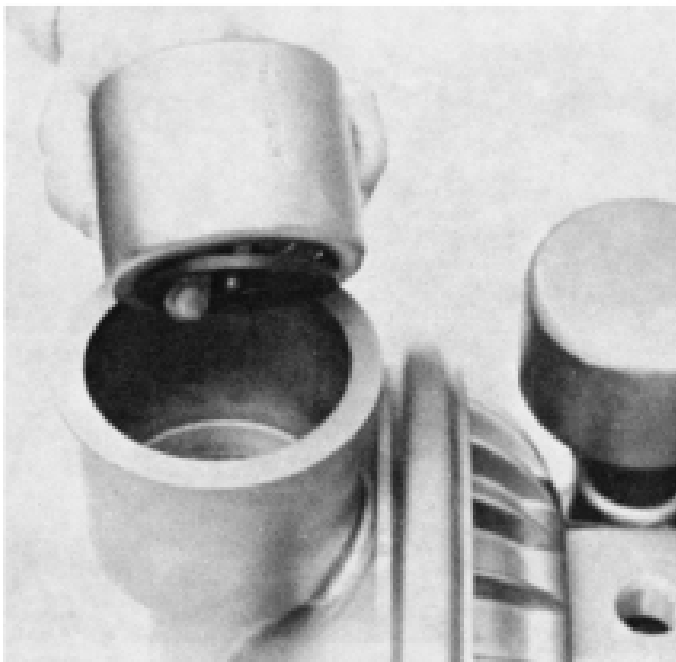

Figure 9A

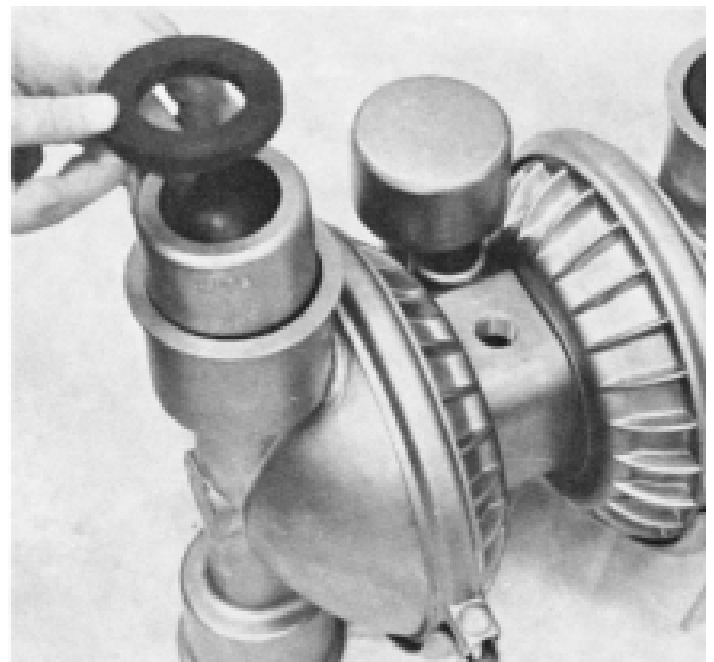

Figure 9B

**Step 4**

Install inlet ball valve cages with square O-ring as in Figure 9A. Observe flow arrow. Remember flow is from bottom to top of pump. Next, install ball valve seats.

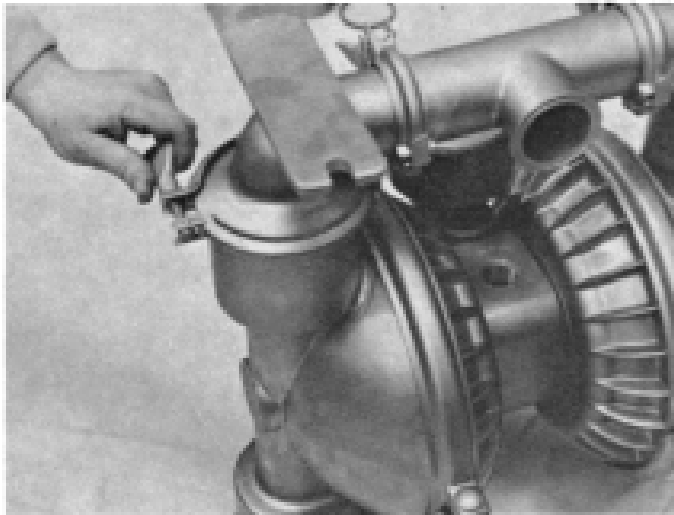

Figure 10A

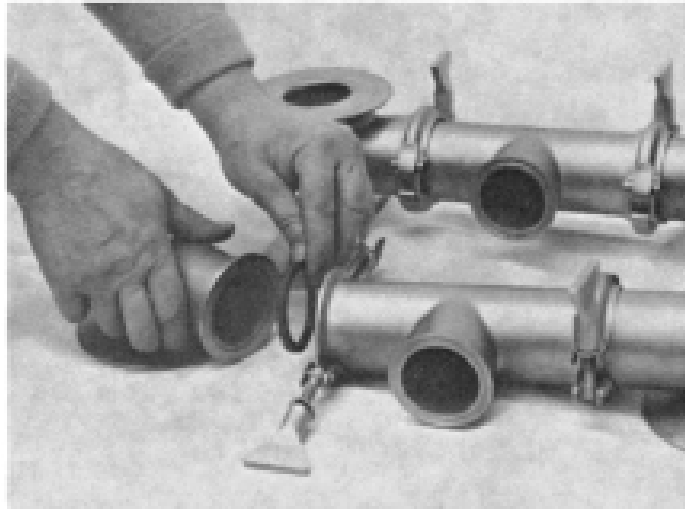

Figure 10B

**Step 5**

Reassemble the three-part inlet manifold. Be sure the square O-rings are installed as in Figure 10B. Turn the pump on its discharge end and install the inlet manifold. Assure that the inlet manifold is square to, and lays flat on, the liquid chambers. Install the clamps and set the pump on the inlet manifold feet.

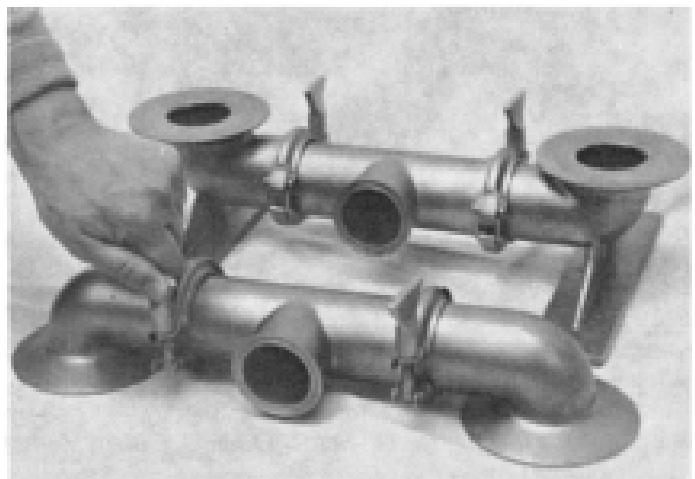

Figure 10C



Figure 11A

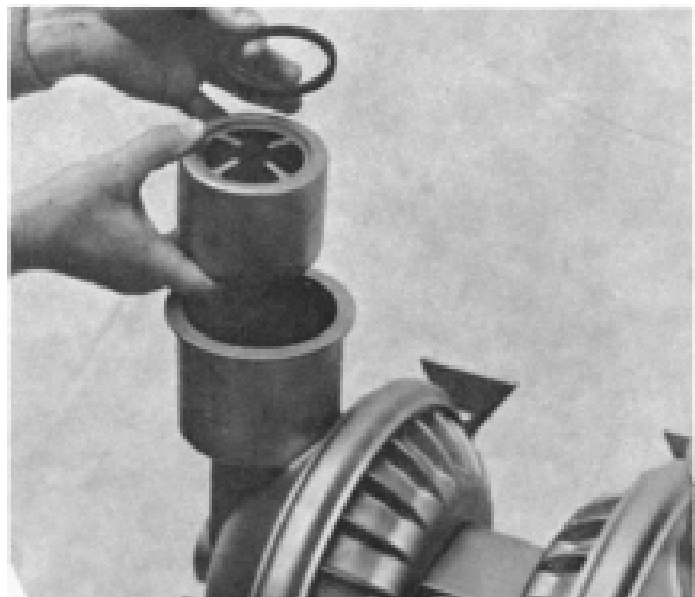

Figure 11B

**Step 6**

Next, install the ball valve seats in the top of the liquid chambers. Place the valve balls on the seats and install the ball valve cage. Place the square O-rings on the ball valve cage and install the discharge manifold.

### **Step 7**

Retighten all clamp bands. Connect an air line to the pump and run it dry. The pump should shift evenly and good suction should be observed at the inlet. Seventeen to twenty inches gauge should be available. If pump does not operate or pull sufficient vacuum, refer to the troubleshooting section in the installation instructions.

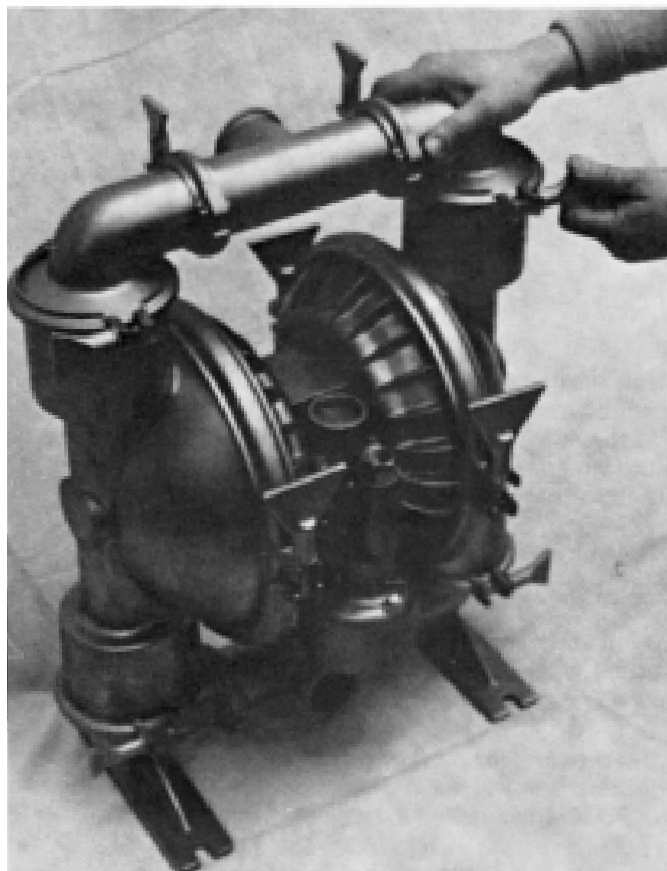

*Figure 12*

### **NOTES:**

## SECTION III

# AIR VALVE/CENTER BLOCK DISASSEMBLY/REASSEMBLY

The air valve assembly consists of both the air valve body and piston and the center block. The unique design of the air valve relies only on differential pressure to effect the diaphragm shift. It is reliable and simple to maintain. The bushing in the center block, along with the the diaphragm shaft, provides the "trigger" to tell the air valve to shift. The following procedures will ensure that the air valve on your Wilden pump will provide long trouble-free service.

### AIR VALVE BODY AND PISTON ASSEMBLY AND DISASSEMBLY:

The air valve body and piston (P/N 08-2000-06-70) can be disconnected from the pump by removing the four socket head cap screws which attach it to the center block (P/N 08-3100-03). The piston in the air valve is aluminum with a dark gray anodized coating. The piston should move freely and the ports in the piston should line up with the ports on the face of the air valve body (see below). The piston should also appear to be a dull, dark gray in color. If the piston appears to be a shiny aluminum color, the air valve is probably worn beyond working tolerances and should be either replaced or returned to the Wilden distributor for rebuild at the Wilden factory.

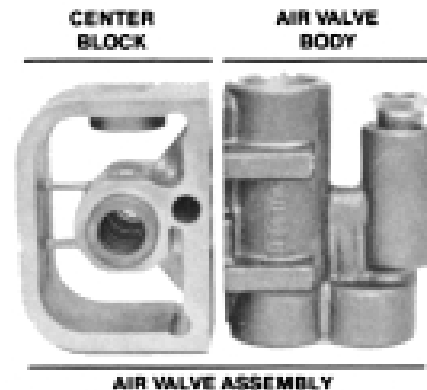

Figure A

If the piston does not move freely in the air valve, the entire air valve should be immersed in a cleaning solution. [NOTE: Do not force the piston by inserting a metal object.] This soaking should remove any accumulation of sludge and grit which is preventing the air valve piston from moving freely. Clean out anti-centering pin holes located each side of the piston. Pin holes are located on each side of the annular groove on the top of the piston and travel to each end. Also, remove and clean the air valve screen (P/N 08-2500-03). If the air valve piston does not move freely after the above cleaning, the air valve should be disassembled as follows: remove the snap ring from the top end of the air valve cylinder and apply an air jet to the 1/4-inch hole on the opposite end of the air valve face (see Figure C). **CAUTION:** The air valve end cap (P/N 08-2330-23) may come out with considerable force. Inspect the piston and cylinder bore for nicks and scoring.

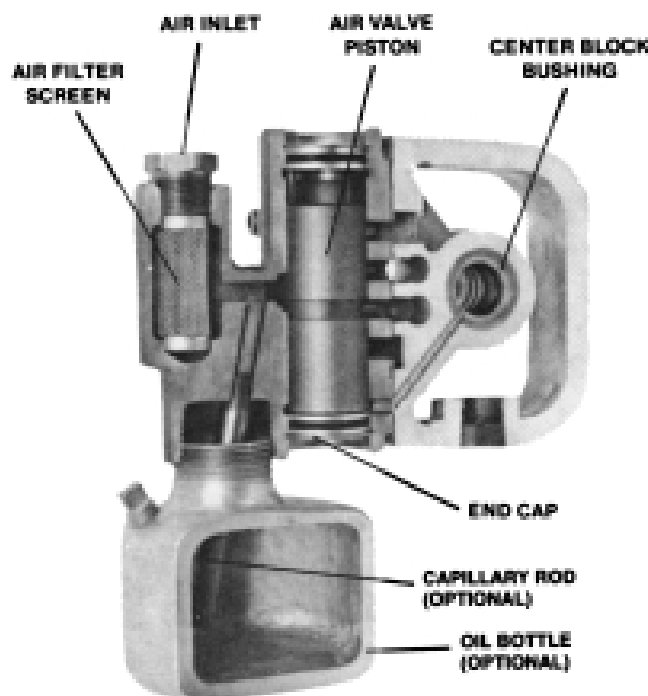

Figure B

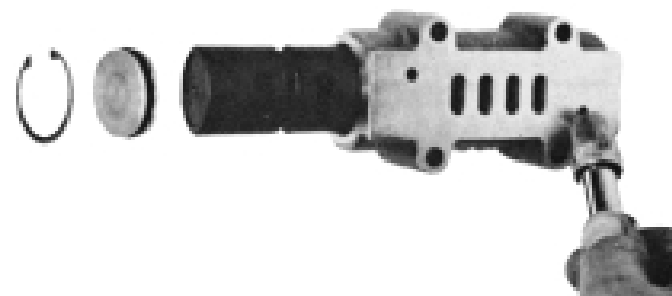

Figure C

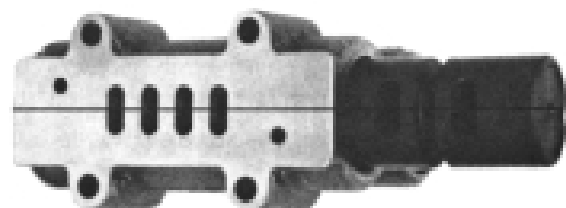

Figure D

Small nicks can usually be dressed out and the piston returned to service. However, deep nicks or heavy scoring will need to be repaired at the factory. Wilden air valves can be rebuilt one time by returning them to the Wilden factory through your local distributor. The oil capillary rod should also be cleaned to ensure proper lubrication of the air valve. Inspect the cylinder end caps (P/N 08-2300-23 has the piston guide pin and P/N 08-2330-23 does not). Make sure that the guide pin is straight and smooth or the piston will not move freely in the cylinder. New O-rings (P/N 08-2390-52) should be installed on the end caps. Lubricate the O-rings and install the end caps, assuring that proper alignment of the piston and cylinder ports is maintained (see *Figure D*). Reinstall air valve to center block of pump.

### GLYD™ RING REPLACEMENT:

When the Glyd™ rings become worn, they will no longer seal and must be replaced. Due to the design characteristics of the Glyd™ rings, it is suggested that you use the ringer seal installation kit when replacing Glyd™ rings (P/N 15-9341-99). Consult EOM-Ringer for installation instructions.

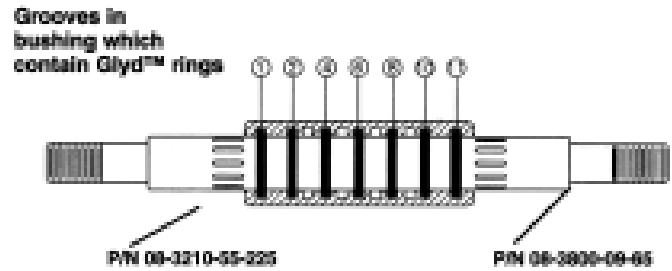

Figure E

### CENTER BLOCK ASSEMBLY (P/N 08-3100-03) AND DISASSEMBLY:

The pump's center block (P/N 08-3100-03) consists of a stainless steel housing with a bronze bushing. The bushing has eleven grooves cut on the inside diameter. There are seven Glyd™ rings that fit in these grooves (see *Figure E*). Since these Glyd™ rings form a part of the shifting function of the pump, it is necessary that they be located in the proper grooves. The bronze bushing is replaceable in cast iron or stainless steel center blocks only.

# EXPLODED VIEW/PARTS LISTING

## T8 SANIFLO<sup>USDA</sup>

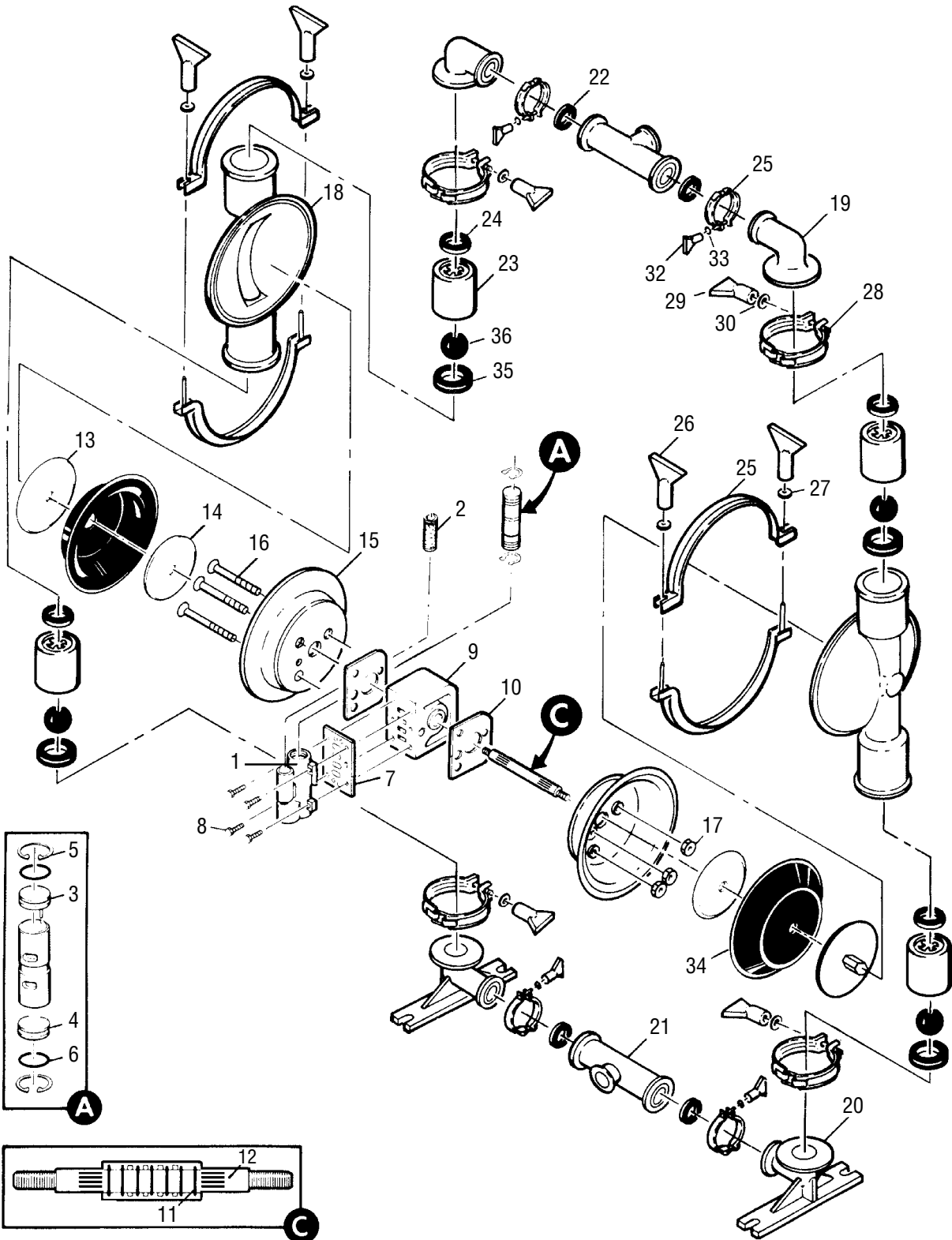

**T8 SANIFLO<sup>USDA</sup>**  
**Models T8/SSSN/072 & T8/SSSN/082**

Item	Description	Qty. Per Pump	Model T8/SSSN/072	Model T8/SSSN/082
			P/N	P/N
<b>1</b>	<b>Air Valve Body &amp; Piston<sup>5</sup></b>	<b>1</b>	<b>08-2000-06</b>	<b>08-2000-06</b>
2	Air Valve Screen	1	08-2500-03	08-2500-03
3	Air Valve Cap with Guide (Top)	1	08-2300-23	08-2300-23
4	Air Valve Cap w/o Guide (Bottom)	1	08-2330-23	08-2330-23
5	Snap Ring <sup>3</sup>	2	08-2650-03	08-2650-03
6	Air Valve Cap O-Ring	2	08-2390-52	08-2390-52
7	Air Valve Gasket	1	08-2600-52	08-2600-52
8	Air Valve Screw <sup>3</sup>	4	08-6000-03	08-6000-03
9	Center Block <sup>2*</sup>	1	08-3100-03-225	08-3100-03-225
<b>10</b>	<b>Block Gasket</b>	<b>2</b>	<b>08-3520-52</b>	<b>08-3520-52</b>
<b>11</b>	<b>Center Block Glyd™ Ring</b>	<b>7</b>	<b>08-3210-55-225</b>	<b>08-3210-55-225</b>
12	Shaft	1	08-3800-09-07	08-3800-09-07
13	Outer Piston <sup>2</sup>	2	08-4550-10-72	08-4550-10-72
14	Inner Piston <sup>2</sup>	2	08-3700-03	08-3700-03
15	Air Chamber <sup>2</sup>	2	08-3650-03	08-3650-03
16	Air Chamber Cap Screw <sup>3</sup>	3	08-6200-03	08-6200-03
17	Air Chamber Cone Nut <sup>3</sup>	3	08-6550-03	08-6550-03
18	Water Chamber <sup>2</sup>	2	08-5000-10-72	08-5000-10-72
19	Discharge Elbow <sup>2</sup>	2	08-5220-10-72	08-5220-10-72
20	Inlet Elbow <sup>2</sup>	2	08-5230-10-72	08-5230-10-72
21	Manifold T-Section <sup>2</sup>	2	08-5160-10-72	08-5160-10-72
22	Manifold O-Ring <sup>4</sup>	4	08-1300-56-72	08-1300-52-72
23	Ball Guide Cage <sup>2</sup>	4	08-5360-10-72	08-5350-10-72
24	Ball Cage O-Ring <sup>4</sup>	4	08-1350-56-72	08-1350-52-72
25	Large Clamp Band Assy. <sup>3</sup>	2	08-7300-03-72	08-7300-03-72
26	Wing Nut (Large) 3/8"-16 <sup>2</sup>	4	08-6670-10-72	08-6670-10-72
27	3/8" Brass Washer	4	08-6720-07-72	08-6720-07-72
28	Medium Clamp Band Assy. <sup>3</sup>	4	08-7200-03-72	08-7200-03-72
29	Wing Nut (Small) 1/2"-16 <sup>2</sup>	4	08-6660-10-72	08-6660-10-72
30	1/2" Brass Washer	4	08-6710-07-72	08-6710-07-72
31	Small Clamp Band Assy. <sup>3</sup>	4	08-7100-03-72	08-7100-03-72
32	Wing Nut (Small) 1/2"-16 <sup>2</sup>	4	08-6660-10-72	08-6660-10-72
33	1/2" Brass Washer	4	08-6710-07-72	08-6710-07-72
<b>34</b>	<b>Diaphragm (Saniflex™)<sup>4</sup></b>	<b>2</b>	<b>08-1010-56</b>	<b>08-1010-56</b>
<b>35</b>	<b>Valve Seat<sup>4</sup></b>	<b>4</b>	<b>08-1120-56-72</b>	<b>08-1120-52-72</b>
<b>36</b>	<b>Valve Balls<sup>4</sup></b>	<b>4</b>	<b>08-1080-68-72</b>	<b>08-1080-55</b>
	Valve Balls (Not Shown)	4	04-1080-55	N/A
	Muffler (Not Shown)	1	08-3510-99	08-3510-99

<sup>1</sup>Electroless Nickel-Plated

<sup>2</sup>316 Stainless Steel

<sup>3</sup>304 Stainless Steel

<sup>4</sup>USDA/FDA-Accepted Thermoplastic

<sup>5</sup>Also available with SS A.V. (P/N 08-2000-03)

Swivel stand (P/N 08-7650-99-72) is available with specialty code 082.

\*Center Block Bushing (P/N 08-3300-07) comes standard with Center Block (P/N 08-3100-03) but may be purchased separately.

**All boldface items are primary wear parts.**

